

B.E.CIVIL ENGINEERING FOURTH YEAR SECOND SEM. EXAM. -2019**Subject: BRIDGE ENGINEERING. Time: Three Hours****Full Marks 100****PART-I (MARKS-60)**

Use a separate Answer-Script for each part

IRC-6, IRC -112, IS 456, SP 16 and required charts and tables are allowed in the exam hall**Assume any other required data if not stated**

No. of questions	<u>Answer question 1 and 2</u>	Marks 15+45=60
1. a) b)	Discuss different type of loading coming on bridges as per Indian code Describe the classification of different types of bridges briefly.	5+10=15
2.	<p align="center"><u>Answer either question no. a) or question no. b)</u></p> <p>A R.C.C. Tee beam girder bridge shown in figure 1. has the following data:</p> <p>Clear width of carriage way=7.5 m Kerbs on either side = 600 by 300 mm Live load : IRC Class AA tracked vehicle Thickness of the wearing coat =80 mm Materials: M-25 Grade concrete and Fe-415 HYSD reinforcements. Three main girders are provided at 2.5 m center to center. The thickness of deck slab 200 mm. Width of main girder 300 mm. Assume depth of main girder and depth and width of cross girder. Cross girders are provided 4 m interval.</p>	

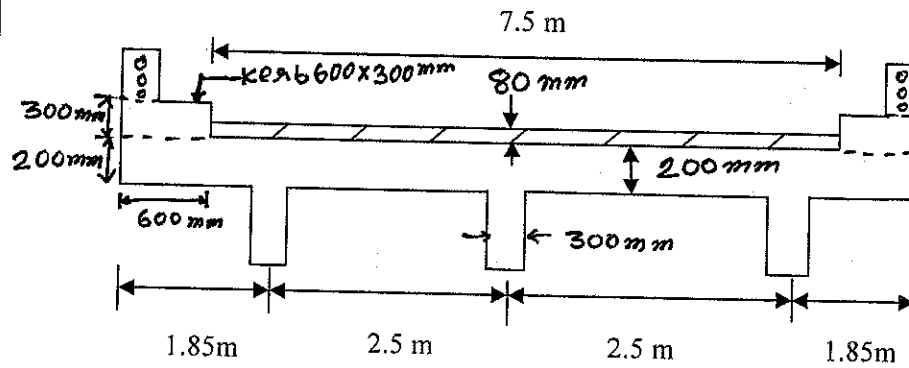

Figure 1.

a) Design the deck slab of the bridge using IRC 6, IRC 112 and IS 456 with the above data and draw the necessary reinforcement detail with neat sketches.

35+10 = 45

b) Design the longitudinal girder and cross girder of the bridge using IRC 6, IRC 112 and IS 456 with the above data and draw the necessary reinforcement detail with neat sketches.

35+10 = 45

B.E. Civil Engineering - Fourth Year - Second Semester-19

Bridge Engineering

PART-II

Time: Three Hours

Full Marks 100

Use a separate Answer-Script for each part
[IS 800, IS 456, IRC 6 are allowed]

No. of questions	Question	Marks (40)
1	<p>Design a well foundation for the pier of a major highway bridge. Internal diameter of a well=2.5, type of soil strata:-clayee ($k=0.033$), depth of well=25m below bed level, material M25 grade of concrete and Fe500 steel.</p> <p style="text-align: center;">Or</p> <p>The foundation of a bridge consists of 10 piles which carry total load 9600 kN. The piles are 400X400 mm and 20 m long. Design one of the pile. Use M30 grade of concrete and Fe 500 grade of steel. Assume any other suitable data.</p>	15
2	<p>Design a steel bridge of span 35m, Roadway=7.5m (two lane), kerbs:600mm, loading: IRC class AA tracked vehicle, materials M30 grade of concrete and Fe 500 HYSD bars for grade slab. Rolled steel sections with an yield stress of 236 N/mm² confirming to IS 226 IRC 24. Do not to design cross girder.</p>	25