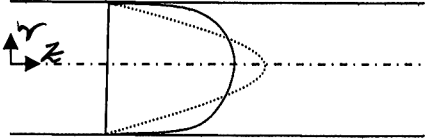

B. E. CHEMICAL ENGINEERING 2nd YEAR 1ST SEMESTER EXAMINATION 2019
 SUBJECT: MECHANICS OF FLUIDS Time: Three hours Full Marks 100

Part I

Use Separate Answer scripts for each Part.

No. of Questions/ CO	MODULE I (answer all the questions)	Marks
1.(CO1) (a) (b)	<p>A velocity field is given by $V=3x(2+\cos(\pi t))i-3y(2+\cos(\pi t))j$</p> <p>(i) Derive the equation of streamline at time $t=0$, passing through (2,4). Does the streamline vary with time?</p> <p>(ii) Is it incompressible and irrotational flow? Justify your answer.</p> <p>Laminar velocity profiles (for same flow rate) of Pseudoplastic and Dilatant fluids are shown in Fig.1. Identify the fluids from the profiles (dotted and solid line). Justify your answer.</p> <div style="text-align: center;">  <p>FIG1</p> </div>	<p>(4+4)</p> <p>(4)</p>
2. (CO 4)	<p>A sharp edged 0.5 inch orifice is installed in a 2 inch (ID) standard steel pipe. Dry air at upstream condition of 20°C and 2 atm flows through the orifice at such a rate that the U tube manometer connected across the taps indicates a reading of 40 cm of red oil. The red oil has a specific gravity of 0.831 referred to water at 20°C. Assume that the orifice discharge coefficient C_o is 0.61.</p> <p>(i) Calculate the weight rate of air flow in the pipe</p> <p>(ii) Estimate permanent head loss across the orifice</p> <p>(iii) What will be reading of a venture meter with same β?</p>	<p>(3+3+2)</p>

B. E. CHEMICAL ENGINEERING 2nd YEAR 1ST SEMESTER EXAMINATION 2019
 SUBJECT: MECHANICS OF FLUIDS Time: Three hours Full Marks 100

No. of Questions	MODULE II (answer either (a) or (b) of each question)	Marks
3. (a) (CO2)	<p>Diffuser is used to reduce the velocity of a flow stream. A particular air diffuser has inlet condition of 250 m/s, 202kPa, 300°C and exit velocity of 50m/s. The diffuser is thermally insulated from the ambient air, and the internal energy change of the air is given by $u_2 - u_1 = (750J/kgC)(T_2 - T_1)$. Find the exit temperature. The ratio of outlet area to inlet area of the diffuser is 4. Find the exit pressure and the force required to hold the diffuser stationary. Neglect elevation change. Assume turbulent flow. Molecular weight of air is 29.</p>	(10)
3(b) (CO2)	<div data-bbox="349 871 1193 1291" style="text-align: center;"> </div> <p>FIG 2</p> <p>A 30° reducing elbow is shown in Fig 2. The fluid is water.</p> <p>(i) Calculate the velocity and Reynolds number at sections 1 and 2</p> <p>(ii) Evaluate the components of forces that must be provided by the adjacent pipes to keep the elbow from moving.</p>	(10)

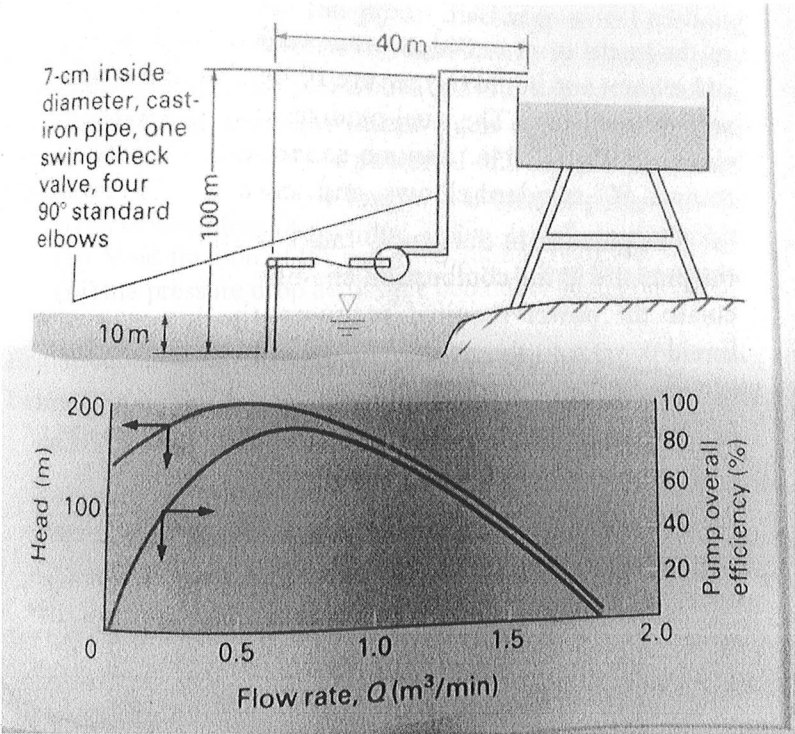
No. of Questions	MODULE II (answer either (a) or(b))	Marks						
4. (a) (CO3)	 <p>7-cm inside diameter, cast-iron pipe, one swing check valve, four 90° standard elbows</p> <p>40 m</p> <p>100 m</p> <p>10 m</p> <p>Head (m)</p> <p>Flow rate, Q (m^3/min)</p> <p>Pump overall efficiency (%)</p> <p>Fig.3</p> <p>A centrifugal pump has the head and efficiency characteristics shown in Fig. 3 and delivers water at 30°C from the lake to the reservoir through cast iron piping ($\epsilon=0.25$ mm).</p> <p>(i) Determine the flow rate and average velocity of water through the piping, which has screwed connections. What is the value of Reynolds number for flow through piping?</p> <p>(ii) What is the head developed by the pump?</p> <p>(iii) What is the pump efficiency?</p> <p>(iv) What motor power is needed?</p> <p>(v) Plot the EGL and HGL.</p> <table border="0" style="width: 100%;"> <tr> <td>Data: Type of fitting</td> <td>Loss coefficient (7cm pipe)</td> </tr> <tr> <td>90° elbow</td> <td>0.8</td> </tr> <tr> <td>Swing check valve</td> <td>2.0</td> </tr> </table>	Data: Type of fitting	Loss coefficient (7cm pipe)	90° elbow	0.8	Swing check valve	2.0	(20)
Data: Type of fitting	Loss coefficient (7cm pipe)							
90° elbow	0.8							
Swing check valve	2.0							

B. E. CHEMICAL ENGINEERING 2nd YEAR 1ST SEMESTER EXAMINATION 2019
 SUBJECT: MECHANICS OF FLUIDS Time: Three hours Full Marks 100

No. of Questions		Marks
4(b). (CO3)	<p>Consider a vertical packed bed consisting of spherical particles ($\rho_p = 1400 \text{ kg/m}^3$) of average diameter 1 mm. The bed is 1 m in diameter by 4 m long. Water ($\rho = 1000 \text{ kg/m}^3$) is used to fluidize the bed. At the minimum fluidizing condition the void fraction, ϵ of the bed is 0.4. At operating condition the bed height is increased by 1.5 times.</p> <p>Calculate</p> <ol style="list-style-type: none"> The operating flow rate of water Void fraction of the bed at operating condition the pressure drop across the bed under such condition, <p>Ergun equation for flow through packed bed having spherical particles is given below:</p> $\frac{(-\Delta P_f) g_c D_p \epsilon^3}{L \rho V_o^2 (1 - \epsilon)} = 150 \frac{(1 - \epsilon)}{N_{Re,p}} + 1.75; V_o \text{ is the superficial velocity.}$ <p>(iv) What is the maximum limit of operating velocity?</p> $C_d = \frac{24}{Re} + \frac{6}{1 + \sqrt{Re}} + 0.44$	(20)

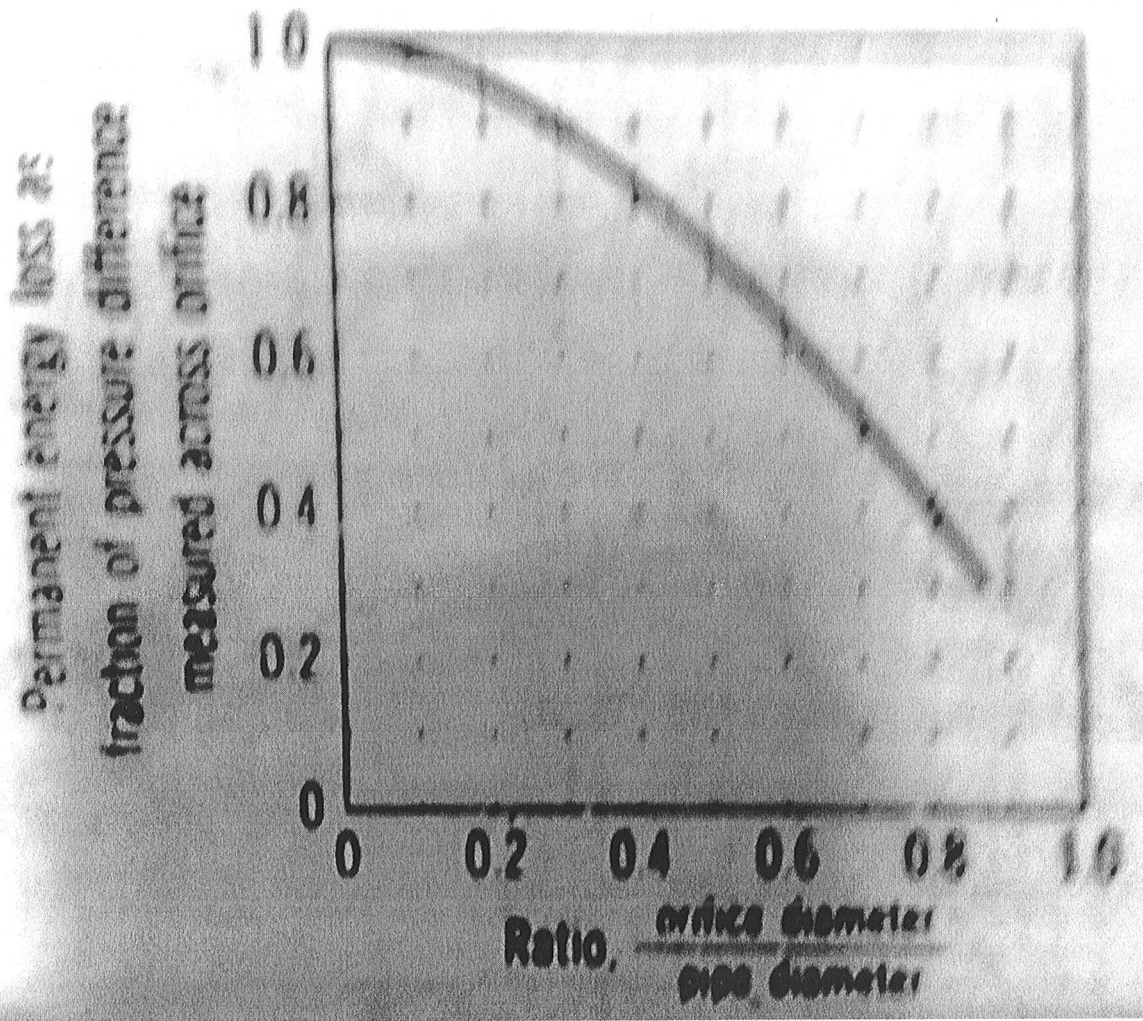

B.E. CHEMICAL ENGINEERING SECOND YEAR FIRST SEMESTER 2019

MECHANICS OF FLUIDS

Part-II

Use separate answer scripts for each part.

Time: Three hours

*Full marks: 100
(50 marks for each part)*

This part contains two modules. Answer all questions from module 1 and any one question from module 2. Assume any missing data.

MODULE 1: Answer all questions

1. (a) Consider a flow field given by $V = 4i + 0.6tj$. Find the equation of the pathline followed by the particle located at $(x,y)=(1,1)$ at the instant $t=0$.
(CO1)
 - (b) Consider a flow field given by $\vec{V} = 2x^2 y\hat{i} - 6y\hat{j} + 4z^2\hat{k}$.
 - (i) Find whether it is a possible incompressible flow.
 - (ii) Find the acceleration of a fluid particle at point $(x,y,z)=(3,1,4)$
- 4+3+5
2. (a) When a plane liquid jet strikes an inclined flat plate, it splits into two streams of equal speed but unequal thickness (Fig 1). For frictionless flow there can be no tangential force on the plate surface. Use this assumption to develop an expression for h_2/h as a function of plate angle θ . Comment on the limiting cases $\theta = 0$ and $\theta = 90^\circ$.
(CO2)

8

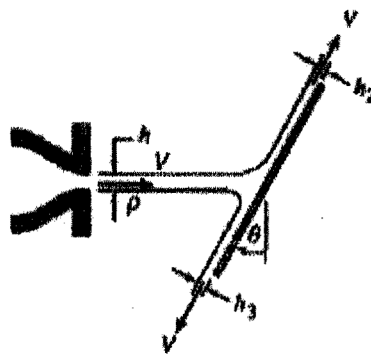

Figure 1

3. (CO4) A fluid having specific gravity 0.82 and viscosity 1×10^{-3} N.s/m² flows through a 0.3 m diameter line in a refinery. The flow rate is expected to be 140-180kg/s. The flow rate has to be measured with maximum uncertainty of 10% because of errors in reading the manometer. A manometer with water as a manometer fluid with an uncertainty of 1 mm is available for use with a venturi meter. Specify a recommended throat diameter of the venturi meter for use with this system. Estimate the amount of maximum

permanent pressure loss for your selected throat diameter. Discharge coefficient for the venturi meter =0.98.

10

MODULE 2: Answer any one question

4. (CO3) (a) Find the discharge Q (m^3/s) through the 150 mm diameter clean cast iron pipeline in Fig.2 for $H=10\text{m}$. Loss coefficients for entrance=0.5, each elbow=0.9, globe valve=10. Assume water density = 998.2 kg/m^3 and viscosity= 10^{-3} Ns/m^2 at 20°C .
(b) Also draw the Energy grade line and Hydraulic grade line.

16+4

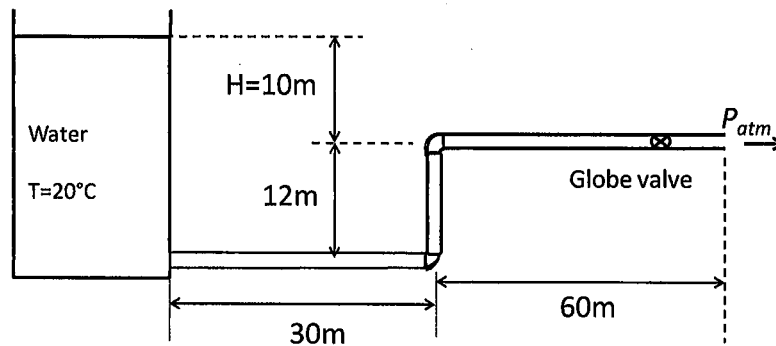

Figure 2

5. (CO3) (a) Two water reservoirs are connected by two cast iron pipes (pipe A and pipe B) in parallel. The length of each pipe is 100 m and the pipe diameters are $D_A = 75 \text{ mm}$ and $D_B = 50 \text{ mm}$. Assume that the reservoirs are open to the atmosphere and the difference in water level is 21 m. Compute the volume flow rate in each pipe. 14
(b) Solid catalyst with particle diameter $40 \times 10^{-6} \text{ m}$ and density 1.5 g/cm^3 is used to contact a hydrocarbon vapor in a fluidized reactor. At operating conditions, the fluid density is $3.4 \times 10^{-3} \text{ g/cm}^3$ and fluid viscosity is 0.02 cP. The bed height is 1 m at rest. Check whether superficial velocity 2.5 cm/s is sufficient to fluidize the bed considering the bed porosity to be 0.42 at the minimum fluidization velocity.
Ergun equation for flow through a packed bed is

$$\frac{\Delta P}{L} \frac{D_p}{\rho v_s^2} \frac{\epsilon^3}{(1-\epsilon)} = 150 \frac{(1-\epsilon)}{N_{Re}} + 1.75$$

6

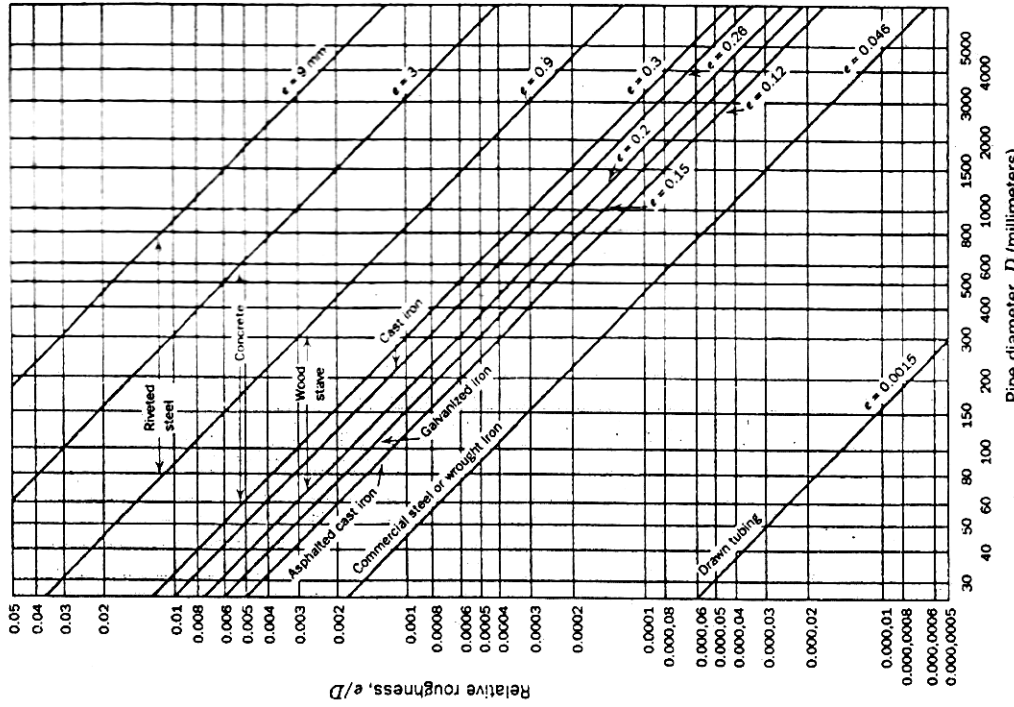

Fig. 8.15 Relative roughness for pipes of common engineering materials. (Data from [6], used by permission.)

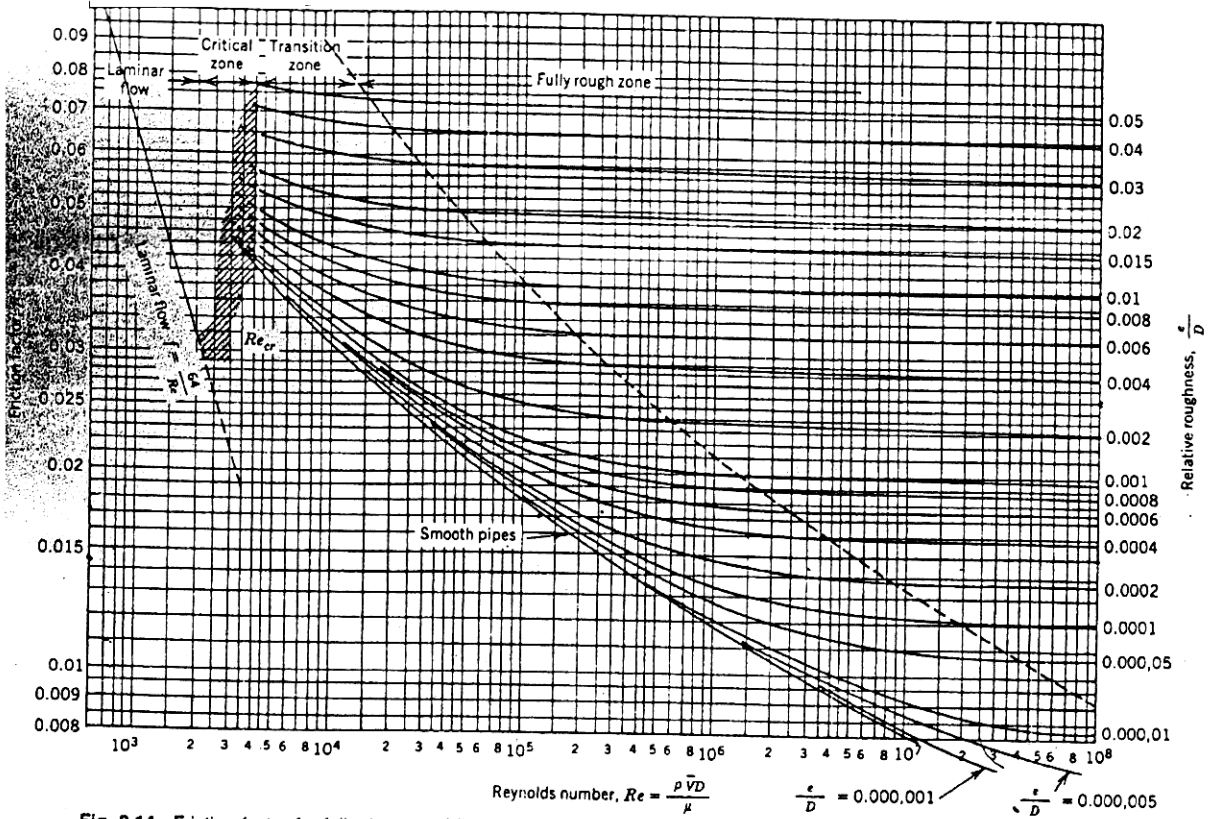

Fig. 8.14 Friction factor for fully developed flow in circular pipes. (Data from [6], used by permission.)