

## B.E.CONSTRUCTION ENGINEERING FIRST YEAR FIRST SEMESTER EXAM - 2019(OLD)

ENGINEERING MECHANICS-I

Time : 3 hours

Full Marks-100

Answer any Eight [8] questions

1. a) Derive the relation of the vector components if the co-ordinate of the system rotate  $\theta$  with respect to X axis?

b) The 30-N force  $P$  is applied perpendicular to the portion BC of the bent bar. Determine the moment of  $P$  about point B and about point A. (Fig-1)

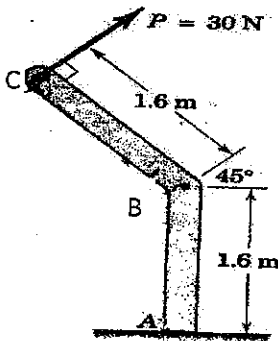

Fig-1

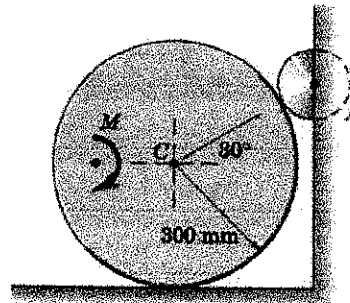

Fig-2

2.a) The 100-kg wheel rests on a rough surface and bears against the roller A when the couple  $M$  is applied. If  $M = 60 \text{ N}\cdot\text{m}$  and the wheel does not slip, compute the reaction on the roller A.

b) State and prove Varignon's theorem.

3.a) Determine the force  $P$  required to bring rolling the uniform cylinder of mass  $m$  over the obstruction of height  $h$ . (Fig-3)

b) For the parking brake lever of prob. Fig-4, the force-couple system at  $O$  equivalent to the force  $F$  is known to consist of a 40-N force and a counterclockwise couple with a moment of 12 N.m. Determine the location  $x$  of the force  $F$ .

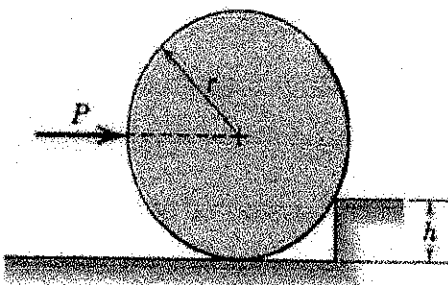

Fig-3

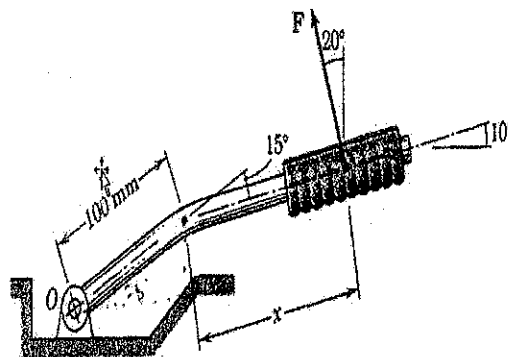

Fig-4

4. a) The tension in the supporting cable AB is 10 kN. Write the force which the cable exerts on the boom BC as a vector  $T$ . Determine the angles  $\theta_x$ ,  $\theta_y$ ,  $\theta_z$  which the line of action of  $T$  forms with the position  $x$ -,  $y$ -,  $z$ -axes. (Fig-5)

b) Two forces  $(P+Q)$  and  $(P-Q)$  make angle  $2\alpha$  with one another, and their resultant makes an angle  $\theta$  with the bisector of the angle between them. Prove that,  $P \tan\theta = Q \tan\alpha$ .

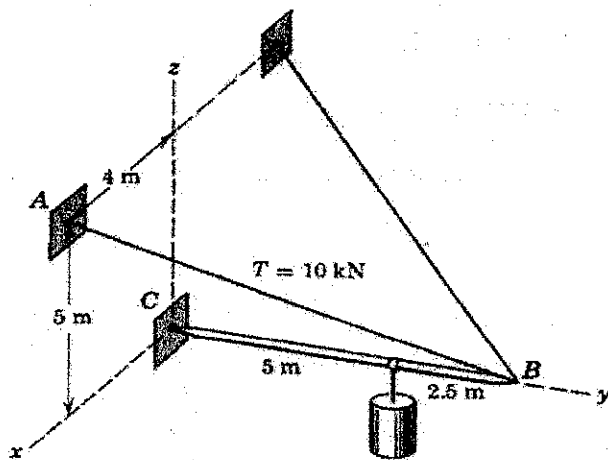

Fig-5

5. a) Find the co-ordinate of the centroid of the shaded area as shown in Fig-6.

b) A force  $F = 400\text{N}$  acting from  $A(3, 2, -5)$  to  $B(6, -2, 5)$ . Find out the force vector.

6. a) Find the location of the centroid of the composite area (Fig-7).

b) Discuss about the effect of equal vector.

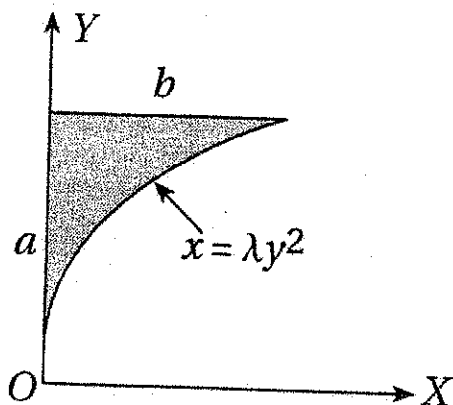

Fig-6

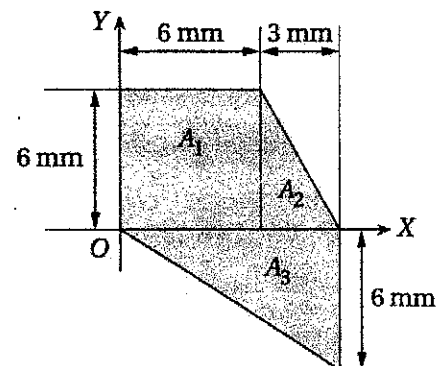

Fig-7

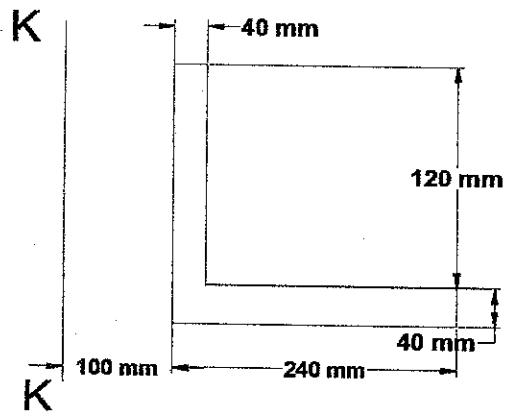

Fig-8

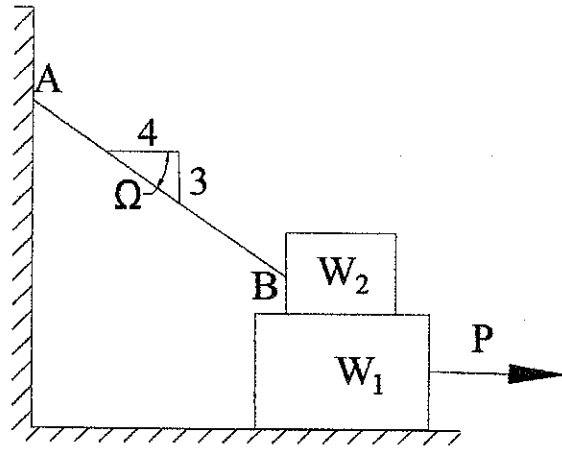

Fig-9

7. Find the moment of Inertia of the L section about K-K axis (Fig-8)

8.  $W_1=200\text{ N}$ ,  $W_2=50\text{ N}$ ,  $\mu=0.3$  (all contact surfaces), Find the necessary  $P$  to impend slipping (Fig-9)

9. a) Given that the forces  $P=4i-2j+3k$ ,  $Q=2i+4j+5k$  and  $R=7i-j+xk$ . Determine the value of  $x$  for which the forces will be coplanar.

b) The beam ABCD has overhangs at each end and carries a uniform load of intensity  $q$ . For what ratio  $b/L$ , will the bending moment at the midpoint of the beam be zero, shown in Fig-10.

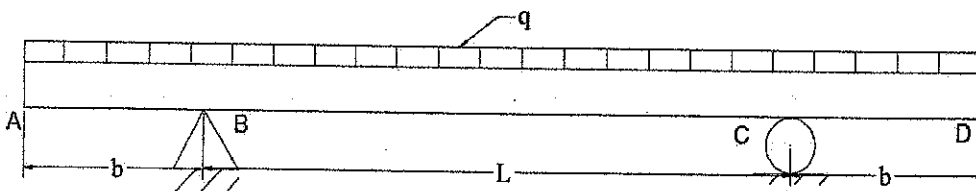

Fig-10

10. Draw the shear force and bending moment diagram of the following figure.

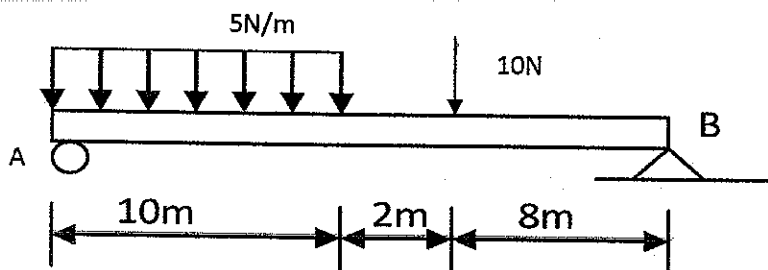

Fig-11

11. Determine the forces on each member by method of joint (Fig-12).

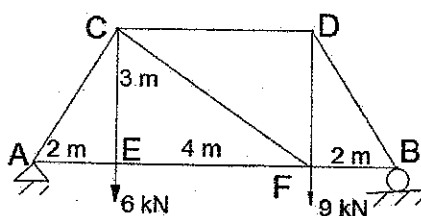

Fig-12