

B.E. INSTRUMENTATION AND ELECTRONICS ENGINEERING**2ND YEAR 1ST SEMESTER, 2023****APPLIED FLUID MECHANICS****Time: Three Hours****Full Marks:100****Answer question No. 1 (compulsory) and any four questions from the rest****Answer to all parts of a question must be together****Assume any data, if not furnished, consistent with the problem.**

- 1.(a) Define absolute and kinematic viscosity mentioning their corresponding SI and CGS units.
What is the significance of kinematic viscosity? 5
- (b) What is the variation of viscosity in fluids with temperature? 5
- (c) The velocity components at point (2, 2) are specified by the equation:
 $u = x^2 + 3y$ and $v = -2xy$. Determine the accelerations and vorticity at this point. 5
- (d) Classify the different types of fluids with example. Draw a neat sketch for the same. 5
- 2.(a) What are the different fluid displacements? Derive the expression for rotation and vorticity of a fluid element. What are the properties of velocity potential function? 2+8+2
- (b) Derive an expression for the force required for axial movement of a shaft through a taper bearing as shown in fig.1. The diameter of the shaft is D m and the length is L m. The clearance at the ends are t_1 m and t_2 m. The oil has a viscosity of μ and the shaft moves axially at a velocity u . 8

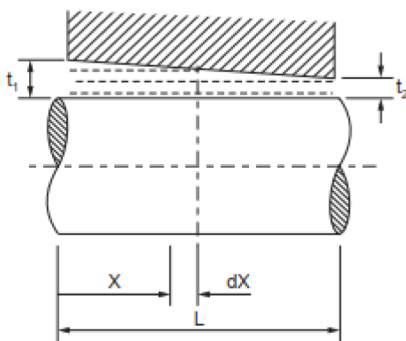

Figure 1

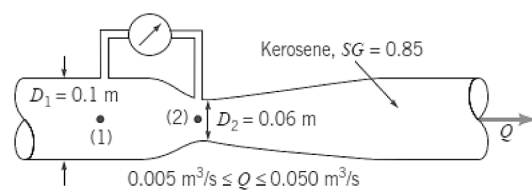

Figure 2

- 3.(a) What is stream tube? Derive the continuity equation in cartesian coordinates. 2+8
- (b) A 50 mm inlet - 25 mm throat venturimeter with a coefficient of discharge of 0.98 is to be replaced by an orifice meter having a coefficient of discharge of 0.6. If both meters are to give the same differential mercury manometer reading for a discharge of 10 l/s, determine the diameter of the orifice. 10

[Turn over

- 4.(a) Kerosene flows through the venturimeter shown in fig.2 with flowrates between 0.005 and 0.050 m³/s. Determine the range in pressure difference, p_1-p_2 , needed to measure these flowrates. 10
- (b) State and derive Hydrostatic law. What are the limitations of a manometer? 6+4
- 5.(a) What is the variation of pressure with depth? Define: absolute, gauge and vacuum pressure. Write the relation between them with neat sketch. 2+4
- (b) Determine the pressure at point A for the situation shown in fig.3. 7
- (c) Water flows in at a rate of 80 l/s from the pipe as shown in fig.4 and flows outwards through the space between the top and bottom plates. The top plate is fixed. Determine the net force acting on the bottom plate. Assume the pressure at radius $r = 0.05\text{m}$ is atmospheric. 7
- 6.(a) Derive the expression for an inverted differential manometer with vessel at different level. 8
- (b) What is Reynolds number and what is its significance? 4
- (c) What is a weir? Derive an expression for discharge over a V-notch. 2+6
- 7.(a) Derive the expression for discharge through an orificemeter. 6
- (b) Derive Darcy-Weisbach equation for turbulent flow. 5
- (c) The stream function for a flow is given by $\psi = xy$. Is the flow irrotational? Determine (i) u, v (ii) the vorticity and (iii) circulation. 4
- (d) Oil of specific gravity 0.8 acts on a vertical triangular area whose apex is in the oil surface. The triangle is isosceles of 3m high and 4m wide. A vertical rectangular area of 2m high is attached to the 4m base of the triangle and is acted upon by water. Find the magnitude and point of action of the resultant hydrostatic force on the entire area. 5

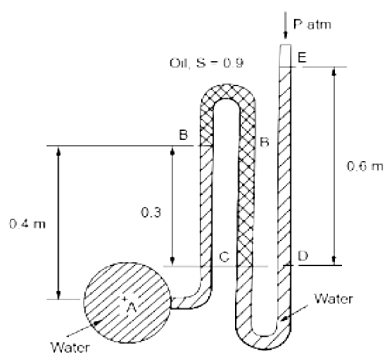

Figure 3

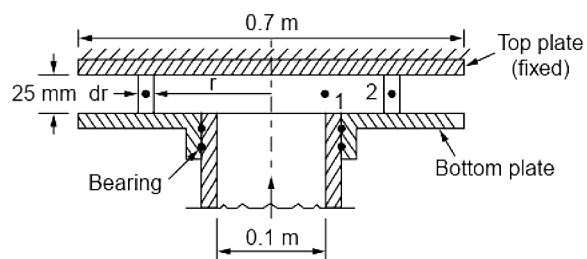

Figure 4