

Name of the Examinations: BACHELOR OF ARCHITECTURE FIRST YEAR FIRST SEMESTER SUPPLEMENTARY EXAM 2023

Subject : STRUCTURAL MECHANICS I

Time: 3 Hours

Full Marks: 100

Instructions:

I	All notations represent their standard relevant meaning.
II	If you feel that any data or condition is/are missing in any question, please assume relevant inputs and mention the same.

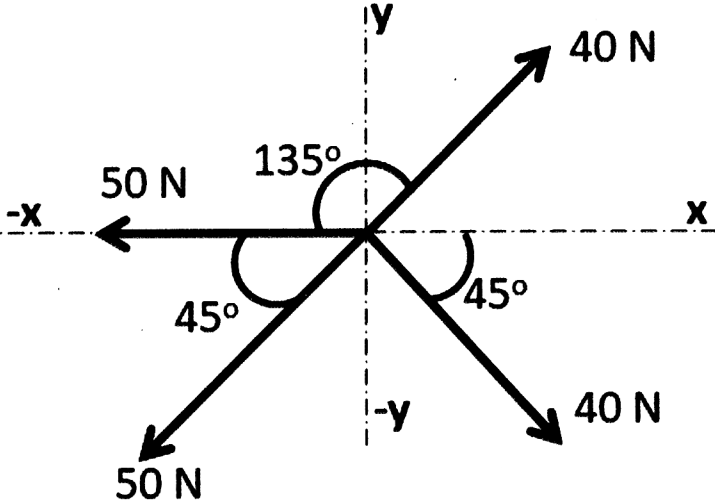
Sl No	Question	Marks
1	 <p style="text-align: center;">Figure: 01 (Not to Scale)</p> <p>Consider the force diagram from <u>Figure: 01</u> and determine resultant of the given force system (magnitude of resultant vector and the angle that the resultant vector makes with respect to positive x axis where x axis and y axis are horizontal and vertical axis respectively perpendicular to each other) by graphical approach using polygon law of vector addition. Also, use analytical approach to get the resultant and compare the results by calculating the percentage of error for the resultant force as well as the angle that the resultant vector makes with respect to the positive x axis.</p>	20
2	<p>Consider a simply supported beam of 9m span where two downward concentrated load of 9kN are acting in perpendicular direction to the span of beam at 3m and 6m from the left support. Determine the support reactions by graphical method using polar diagram and funicular polygon. Also determine the reactions analytically and compare the results to find percentage of errors for each support reactions.</p>	20

[Turn over

3

20

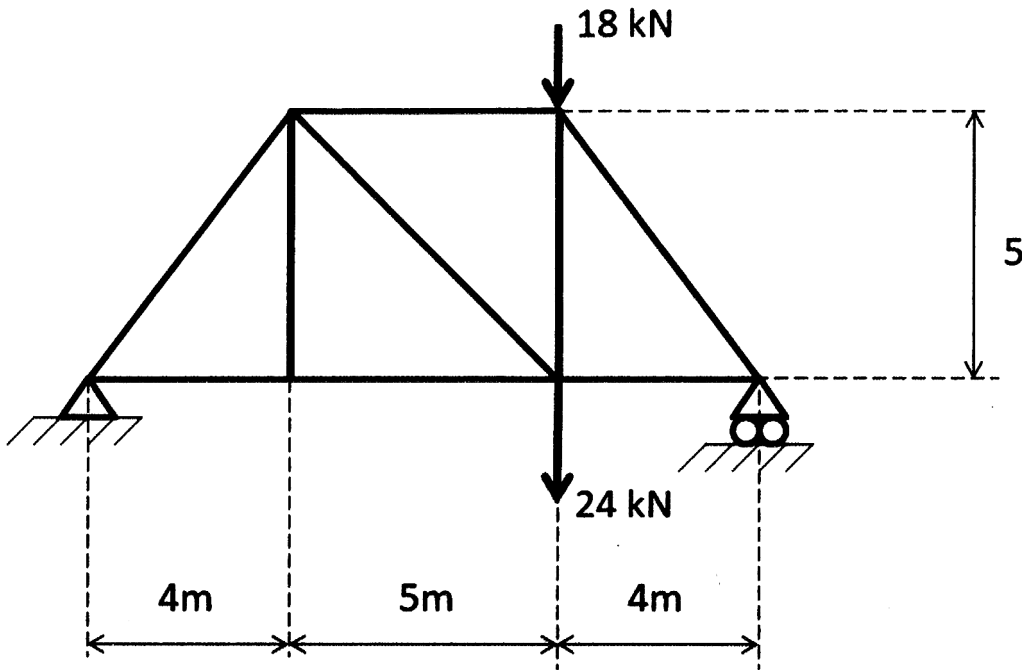

Figure: 02 (Not to Scale)

Consider the geometrically symmetric determinate plane truss from Figure: 02 and determine all member forces by using method of joints (Show the member forces and joint forces in the diagram with proper notations).

4

20

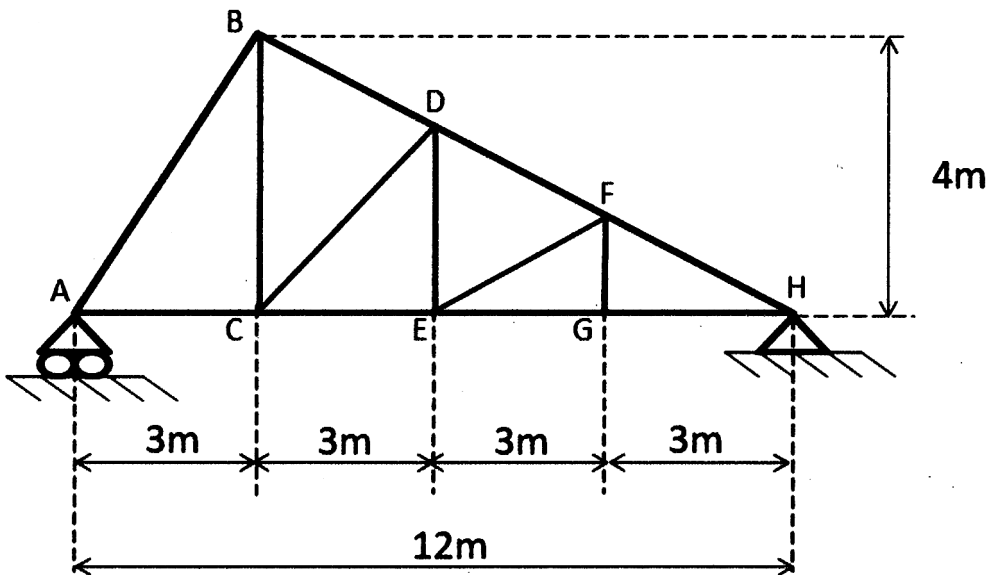

Figure: 03 (Not to Scale)

Consider the plane truss from Figure:03 and check if the truss is statically indeterminate in nature. Identify zero force member(s) in the truss. Use method of section and determine the member forces only for Member CE, DE and DF (Show member forces and and joint forces in the diagram with proper notations).

- 5 Derive the expression of moment of inertia of a rectangular solid section of a prismatic beam of uniform cross section along its neutral axis.(12 marks) 20

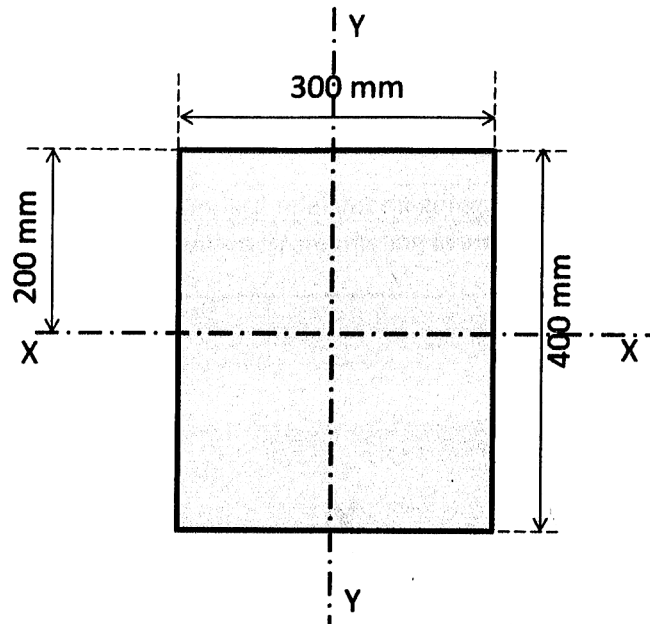

Figure: 04 (Not to Scale)

Consider the solid rectangular column cross section given in Figure: 04 and determine Moment of Inertia for the section with respect to XX and YY axis where XX and YY axis shown in the figure are perpendicular to each other. (8 marks)