

**BACHELOR OF MECHANICAL ENGG. EXAMINATION, 2017 (OLD)**  
**(3<sup>rd</sup> Year, 1<sup>st</sup> Semester, Supplementary)**

**MACHINE DESIGN - II**

Time : 3 hrs

Data if missing may be assumed reasonably

Full Marks: 100

The symbols used in the questions, bear their usual meaning

Relevant tables are provided at the end

Answer any **Five (5)** questions

1. (a) A semi elliptical leaf is to be selected for suspension related application. The spring should consist of three extra full-length leaves and 15 graduated-length leaves (including the master leaf). The centre to centre distance between the two eyes of the spring is to be fixed at 1.0 m based on assembly constraints. The maximum expected load on the spring is 75 kN. The leaves are to be made of steel and the spring is to be pre-stressed in such a way that when the maximum loads acts, the stresses induced in all leaves are same and equal to  $450\text{N/mm}^2$ . Work out the following:
  - i) Select suitable standard leaf size from the table provided.
  - ii) The initial nip.
  - iii) Initial pre-load required for closing the nip between extra full-length leaves and graduated-length leaves [10]
 (b) Design a spring for a balance to measure 0 to 1000 N over a suitable scale of length. The spring is to be enclosed in a casing of 25 mm diameter. The approximate number of turns is 30. The modulus of rigidity is  $85\text{kN/mm}^2$ . Also calculate the maximum shear stress induced. [10]
  
2. Design a rigid flange coupling capable of transmitting 75 kW at 500 rpm. Materials for shaft, key and bolt are to be suitably chosen. The coupling halves are made of grey cast iron FG200. Specify all the major dimensions of the coupling with appropriate notations and draw a free hand sketch of the coupling. [15 + 5]
  
3. (a) In a crossed leather belt drive, the smaller (driver) and the larger pulleys rotate at 1000 rpm and 500 rpm respectively and the center distance between them is 1500 mm. The 6 mm thick belt transmits 7.5 kW with a slip of 4% at the smaller pulley and operates at a velocity of 13 m/s approximately. Assume the coefficient of friction to be 0.3, the allowable tensile stress for the belt material as  $1.75\text{ N/mm}^2$  and the density of leather to be 0.95 g/cc. Calculate (i) length and width of the belt and (ii) belt tensions on the tight and slack sides. [10]
 (b) What is the importance of initial tension in belt drives? What is creep phenomenon? [05]
 (c) Discuss the merits and demerits of V-belt over flat belts. [03]
 (d) Why the arms of the pulley are generally elliptical in cross section? [02]
  
4. (a) A single plate clutch consists of one pair of contacting surfaces. The outer diameter (D) of contacting surfaces is fixed because of space limitations. The permissible intensity of pressure is  $P_a$  and the coefficient of friction is  $\mu$ . Assuming uniform wear theory, show that the torque transmitting capacity of the clutch is maximum when the ratio of diameters (d/D) is equal to 0.577. [05]
 (b) A centrifugal clutch with four shoes is to be designed to transmit 15 kW at 900 r.p.m. The speed at which the engagement begins is 3/4th of the running speed. The inside diameter of the pulley rim is 300 mm. The shoes are lined with Ferrodo for which the coefficient of friction may be taken as 0.25 and the maximum permissible pressure as  $0.1\text{ N/mm}^2$ . Assume that the centre of gravity of the shoes

lie 30 mm radially inside from the surface of the rim and each shoe subtends an angle of  $60^\circ$  at the centre of the spider. Determine: i) Mass of the shoes and ii) Size of the shoes. [08]

(c) A 100mm wide steel band with a tensile failure stress of  $275 \text{ N/mm}^2$  is employed in a differential band brake (as shown below). The coefficient of friction between the friction lining and the brake drum is 0.26. Calculate: (i) The tensions in the band, (ii) The actuating force and (iii) The torque capacity of the brake. Also find whether the brake is self-locking. [07]

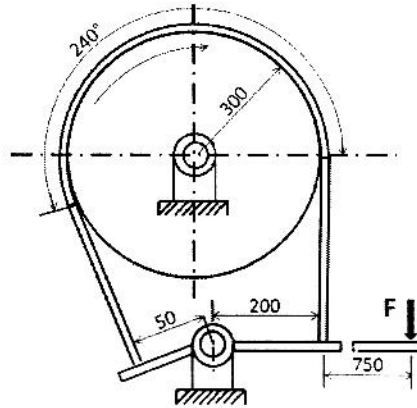

5. A steel pinion ( $\sigma_o = 103 \text{ MN/m}^2$ ,  $E = 2 \times 10^5 \text{ N/mm}^2$ ) rotating at 900 rpm is to drive a cast iron spur gear ( $\sigma_o = 55 \text{ MN/m}^2$ ,  $E = 1 \times 10^5 \text{ N/mm}^2$ ) at 144 rpm. The teeth are to have standard  $20^\circ$  stub involute profiles and the maximum power to be transmitted is 25 kW. Determine the proper module, number of teeth and the face width for these gears from the standpoint of strength, dynamic load and wear. Pinion is surface hardened to BHN250. Lewis form factor for pinion and gear are 0.115 and 0.161 respectively. Assume allowable bending stress  $\sigma_b = 0.5 \sigma_o$ . Load stress fatigue factor for steel pinion (BHN 250) and cast iron gear is  $1310 \text{ kN/m}^2$ . [20]
6. Design a pair of helical gears for transmitting 22 kW at a speed reduction ratio of 3:1. The speed of the driver gear is 1800 r.p.m. The helix angle is  $30^\circ$  and profile is corresponding to  $20^\circ$  full depth system. The driver gear has 24 teeth. Both the gears are made of cast steel with allowable static stress as 50 MPa. Assume the face width parallel to axis as 4 times the circular pitch and the overhang for each gear as 150 mm. The allowable shear stress for the shaft material may be taken as 50 MPa. The form factor may be taken as  $(0.154 - 0.912/T_E)$ , where  $T_E$  is the equivalent number of teeth. The velocity factor may be taken as  $350/(350+v)$  where  $v$  is pitch line velocity in m/min. The gears are required to be designed only against bending failure of the teeth under dynamic condition. Also evaluate the diameters of the respective mounting shafts. The design for rim, arms and gear shaft may be excluded. [20]
7. (a) A pair of straight bevel gears consist of a 24-teeth pinion meshing with a 48 teeth gear. The module at the outside diameter is 6 mm while the face width is 50 mm. the gears are made of grey cast iron FG 220 ( $S_{ut} = 220 \text{ N/mm}^2$ ). The pressure angle is  $20^\circ$ . The teeth are generated and assume that velocity factor accounts for dynamic load. The pinion rotates at 300 rpm and the service factor is 1.5. Calculate: (i) The beam strength of the tooth, (ii) The static load that the gears can transmit with a factor of safety of 2.0 for bending consideration and (iii) The rated power that the gears can transmit. [10]
- (b) A pair of worm is designated as 1/40/10/4. The input speed of the worm shaft is 1000 rpm. The worm wheel is made of phosphor-bronze (sand cast), while the worm of case hardened carbon steel 10C4. Determine the power transmitting capacity based on beam strength. [10]

## Data for Reference

**Table 1 List of materials and their properties**

Grade	Tensile strength (N/mm <sup>2</sup> )	Yield strength (N/mm <sup>2</sup> )
<i>Cast Iron</i>		
FG 150	150	--
FG 200	200	--
FG 260	260	--
FG 300	300	--
FG 400	400	--
<i>Plain carbon steel</i>		
7C4	320	--
10C4	340	--
30C8	500	400
40C8	580	380
45C8	630	380
50C4	660	460
55C8	720	460

**Table 2: Standard dimensions for leaves**

Standard thickness of leaves (mm)	Standard width of leaves (mm)
3.2, 4.5, 5, 6, 6.5, 7, 7.5, 8, 9, 10, 11, 12, 14, 16	32, 40, 45, 50, 55, 60, 65, 70, 75, 80, 90, 100, 125

**Table 3: Standard size of spring wire diameter**

SWG	Diameter (mm)	SWG	Diameter (mm)	SWG	Diameter (mm)	SWG	Diameter (mm)
7/0	12.70	7	4.470	20	0.914	33	0.2540
6/0	11.785	8	4.064	21	0.813	34	0.2337
5/0	10.973	9	3.658	22	0.711	35	0.2134
4/0	10.160	10	3.251	23	0.610	36	0.1930
3/0	9.490	11	2.946	24	0.559	37	0.1727
2/0	8.839	12	2.642	25	0.508	38	0.1524
0	8.229	13	2.337	26	0.457	39	0.1321
1	7.620	14	2.032	27	0.4166	40	0.1219
2	7.010	15	1.829	28	0.3759	41	0.1118
3	6.401	16	1.626	29	0.3454	42	0.1016
4	5.893	17	1.422	30	0.3150	43	0.0914
5	5.385	18	1.219	31	0.2946	44	0.0813
6	4.877	19	1.016	32	0.2743	45	0.0711

**Table 4: Proportions of standard parallel, tapered and gib head keys**

Shaft diameter (mm) upto and including	Key cross-section		Shaft diameter (mm) upto and including	Key cross-section	
	Width (mm)	Thickness (mm)		Width (mm)	Thickness (mm)
6	2	2	85	25	14
8	3	3	95	28	16
10	4	4	110	32	18
12	5	5	130	36	20
17	6	6	150	40	22
22	8	7	170	45	25
30	10	8	200	50	28
38	12	8	230	56	32
44	14	9	260	63	32
50	16	10	290	70	36
58	18	11	330	80	40
65	20	12	380	90	45
75	22	14	440	100	50

**Table 5 Standard bolt size.**

Designation	Nominal or major dia d/D (mm)	Pitch (p) (mm)	Pitch diameter $d_p/D_p$ (mm)	Minor diameter		Tensile stress area (mm <sup>2</sup> )
				$d_c$ (mm)	$D_c$ (mm)	
M 4	4	0.70	3.545	3.141	3.242	8.78
M 5	5	0.80	4.480	4.019	4.134	14.20
M 6	6	1.00	5.350	4.773	4.917	20.10
M 8	8	1.25	7.188	6.466	6.647	36.60
M 10	10	1.50	9.026	8.160	8.376	58.00
M 12	12	1.75	10.863	9.853	10.106	84.30
M 16	16	2.00	14.701	13.546	13.835	157
M 20	20	2.50	18.376	16.933	17.294	245
M 24	24	3.00	22.051	20.319	20.752	353
M 30	30	3.50	27.727	25.706	26.211	561
M 36	36	4.00	33.402	31.093	31.670	817
M 42	42	4.50	39.077	36.479	37.129	1120
M 48	48	5.00	44.752	41.866	42.587	1470
M 56	56	5.50	52.428	49.252	50.046	2030
M 64	64	6.00	60.103	56.639	57.505	2680
M 72	72	6.00	68.103	64.639	65.505	3460
M 80	80	6.00	76.103	72.639	73.505	4340
M 90	90	6.00	86.103	82.639	83.505	5590
M 100	100	6.00	96.103	92.639	93.505	7000

**Table 6: Relationship between belt and pulley widths**

<i>Belt width in mm</i>	<i>Width of pulley to be greater than belt width by (mm)</i>
upto 125	13
125-250	25
250-375	38
475-500	50

**Table 7: Standard pulley diameters**

<b>Standard Pulley Diameters (mm)</b>
40, 45, 50, 56, 63, 71, 80, 90, 100, 112, 125, 140, 160, 180, 200, 224, 250, 280, 315, 355, 400, 450, 500, 560, 630, 710, 800, 900, 1000, 1120, 1250, 1400.

**Table 8: Form Factors  $y$  – for use in Lewis strength equation**

<i>Number of Teeth</i>	<i>14.5° Full-Depth Involute or Composite</i>	<i>20° Full-Depth Involute</i>	<i>20° Stub Involute</i>
12	0.067	0.078	0.099
13	0.071	0.083	0.103
14	0.075	0.088	0.108
15	0.078	0.092	0.111
16	0.081	0.094	0.115
17	0.084	0.096	0.117
18	0.086	0.098	0.120
19	0.088	0.100	0.123
20	0.090	0.102	0.125
21	0.092	0.104	0.127
23	0.094	0.106	0.130
25	0.097	0.108	0.133
27	0.099	0.111	0.136
30	0.101	0.114	0.139
34	0.104	0.118	0.142
38	0.106	0.122	0.145
43	0.108	0.126	0.147
50	0.110	0.130	0.151
60	0.113	0.134	0.154
75	0.115	0.138	0.158
100	0.117	0.142	0.161
150	0.119	0.146	0.165
300	0.122	0.150	0.170
Rack	0.124	0.154	0.175

**Table 9: Values of Surface Endurance Limit and Stress Fatigue Factor**

Average Brinell Hardness Number of steel pinion and steel gear		Surface Endurance Limit $s_{su}$ (MN/m <sup>2</sup> )	Stress Fatigue Factor K (kN/m <sup>2</sup> )	
			14.5°	20°
150		342	206	282
200		480	405	555
250		618	673	919
300		755	1004	1372
400		1030	1869	2553
Brinell Hardness Number, BHN				
Steel pinion	Gear			
150	C.I.	342	303	414
200	C.I.	480	600	820
250	C.I.	618	1000	1310
150	Phosphor Bronze	342	317	427
200	Phosphor Bronze	445	503	689
C.I. Pinion	C.I. Gear	549	1050	1428
C.I. Pinion	C.I. Gear	618	1330	1960

**Table 10: Partial List, Material Factor  $C_m$**

Gear		Pinion		$C_m$
Material	BHN	Material	BHN	
I	160-200	II	210-245	0.30
II	245-280	II	285-325	0.40
II	285-325	II	335-360	0.50
II	210-245	III	500	0.40
II	285-325	IV	550	0.60
III	500	IV	550	0.90
IV	500	IV	550	1.00

**Table 11 Values of tooth error vs module**

Module (mm)	4	5	6	7	8	9	10	12	14	16
Tooth error (mm)	0.051	0.055	0.065	0.071	0.078	0.085	0.089	0.097	0.104	0.110

**Table 12: Values of bending stress factor ( $S_b$ ) for worm materials**

Material	$S_b$
Phosphor-bronze (centrifugally cast)	7.00
Phosphor-bronze (sand-cast and chilled)	6.40
Phosphor-bronze (sand-cast)	5.00
0.4% Carbon steel-normalized (40C8)	14.10
0.55% Carbon steel-normalized (55C8)	17.60
Case-hardened carbon steels (10C4, 14C6)	28.20
Case-hardened alloy steels (16Ni80Cr60 and 20Ni2Mo25)	33.11
Nickel-chromium steels (13Ni3Cr80 and 15 Ni4Cr1)	35.22

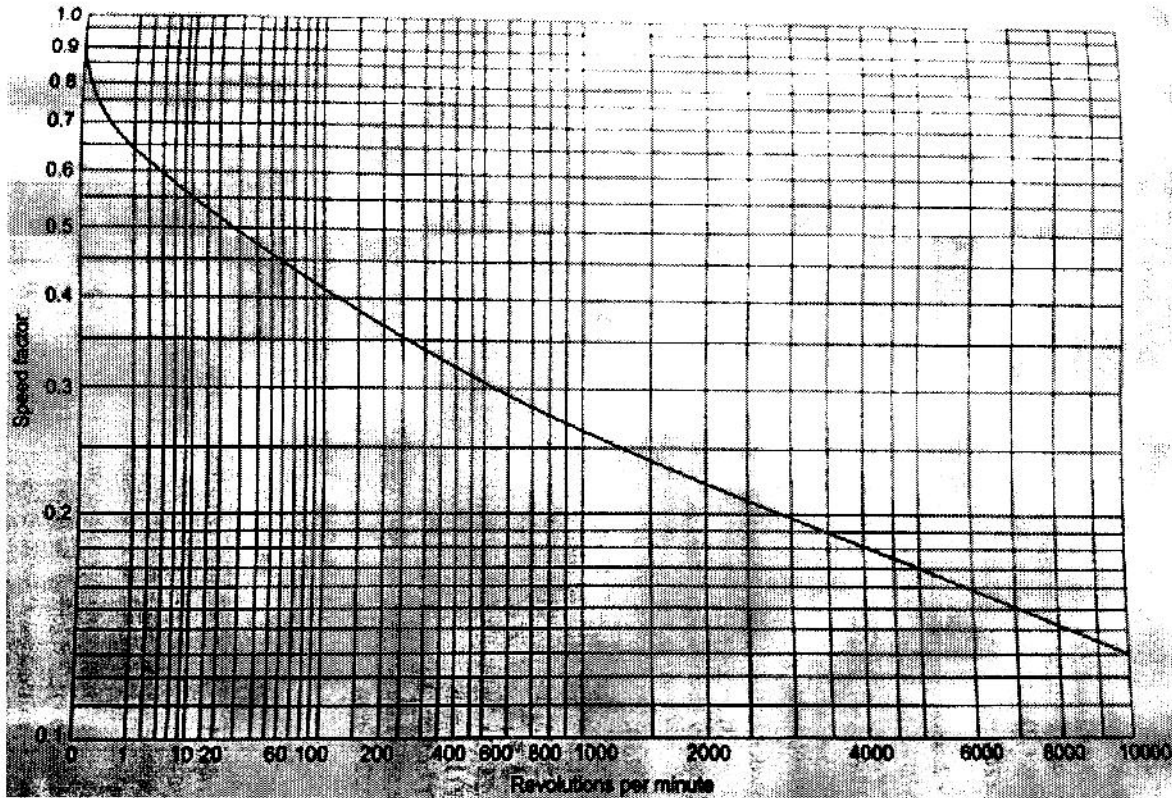

**Fig 1: Speed factor for worm gears for strength**