

Name of the Examinations: B.CHEM. 2ND YR 1ST. SEM. EXAM.-2017

Subject : ELEMENTARY ELECTRONICS

Time: 3 hours

Full Marks:100

Instructions: Answer question 1 and 4 other questions. (5X20=100). Write to the point and handwriting should be clean and clear else marks will be deducted.

1. For each of the statements below indicate whether the statement is true or false. 1 × 20

- i) Donor materials have 5 electrons in the valence shell.
- ii) The output of the common collector is in phase with the input voltage.
- iii) The base of pnp transistor is lightly doped.
- iv) The base-emitter junction in a CE amplifier is reverse biased.
- v) JFET is unipolar device.
- vi) When J and K is joined in J-K flip-flop, it is called D flip-flop.
- vii) When the inputs of R-S flip-flop are joined it is called D flip-flop.
- viii) If the base current of CE BJT, $I_b=20\text{ma}$, $\beta=100$ then collector current $I_c=2\text{A}$.
- ix) Flip-flop is an example of combinational logic circuit.
- x) $A+AB=1$
- xi) In forward bias condition current does not flow through zener diode.
- xii) Avalanche diode is less doped w.r.t. zener diode.
- xiii) Zener diode has positive temperature coefficient.
- xiv) Current direction is same as the direction of flow of the hole.
- xv) Diffusion current flows due to movement of carriers under electric field.
- xvi) Built in potential is generated across depletion region.
- xvii) Current density of any carrier= $\text{conductivity} \times \text{Electric field}$
- xviii) At forward bias voltage across depletion region of diode decreases from built in potential.
- xix) Zener diode can be used for voltage regulation.
- xx) Biasing is done to set the Q point.

2. i) Find the voltage curve across AB . Mark the different voltage amplitudes in the curve. The diodes are normal diodes.

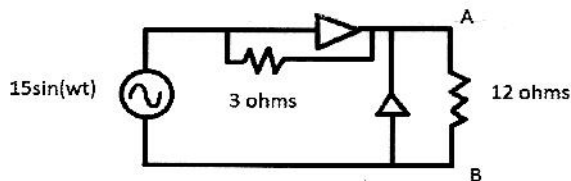

[2]

- ii) A semiconductor bar has intrinsic carrier concentration 1.5×10^{10} /cc. It is doped with Phosphorous atom with concentration 10^4 /cc. Find the concentration of hole after doping. 3
- iii) What is clipper? Draw and explain positive and negative clipper. 1+2+2
- iv) Find voltage curve across AB. Mark the different voltage amplitudes. The forward voltage drop across zener diodes are 0 and zener voltages are 0.5 volt. 7

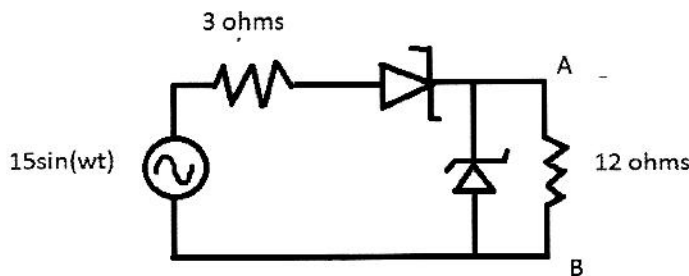

3. i) What is ripple factor for rectifier? What is the ripple factor for centre tapped full wave rectifier? 2+1
- ii) Calculate the following for half wave rectifier:
- a) DC output current
 - b) RMS output current
 - c) Ripple Factor
 - d) Efficiency 3x4
- iii) Draw and explain how bridge rectifier converts ac voltage to pulsating dc. 5
4. i) What do you mean by the term "Transistor"? Draw the circuit for common emitter and common collector BJT. 1+2+2
- ii) Draw and explain all the current components of a common emitter npn BJT due to hole and electrons. 5
- iii) Draw base bias, emitter bias and voltage divider bias circuits of common emitter BJT. 2x3

iv) Find I_c for the circuit below. Consider $V_{BE}=0.7$ volts.

4

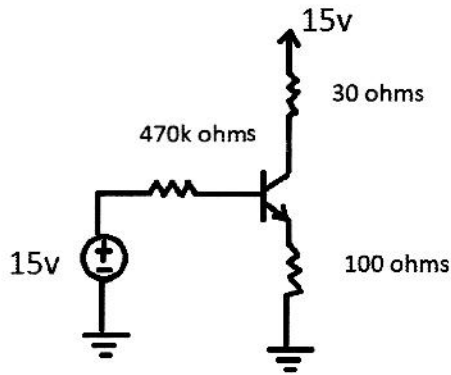

5. i) Draw output characteristics and transfer characteristics curve for JFET.

2+2

ii) Find the current through JFET when $V_{GS}=2v, V_P=0.2v, V_{DS}=2v, I_{DSS}=0.7$ mA.

4

iii) What is pinch off voltage? Draw and explain.

4

iv) What is the purpose of bypass and coupling capacitor? Draw the small signal high frequency equivalent circuit of the following BJT circuit.

2+2+ 4

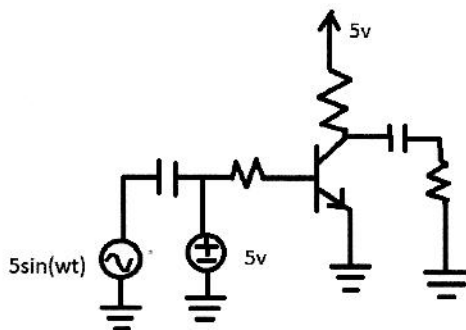

6. i) Convert decimal to binary: $(235)_{10} = (?)_2, (0.125)_{10} = (?)_2$

2+2

ii) Simplify the expression of Y using k map.

$$Y = f(A, B, C, D) = \sum (m_0, m_2, m_3, m_4, m_5, m_{10}, m_{12}, m_{13})$$

5

iii) Write the expression for Z [f(A,B,C)] in canonical SOP form.

$$Z = AB + BC + \overline{B}$$

4

iv) Write the simplified expressions of X, Y, Z and P in terms of A and B.

4

[4]

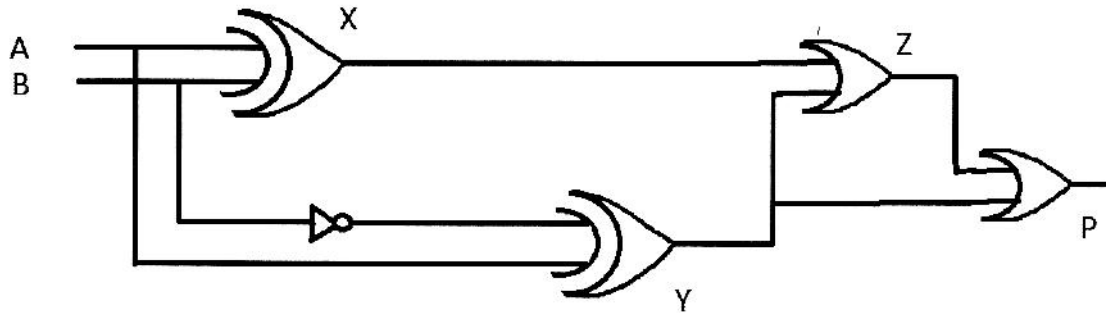

V) Simplify the expression: $X=(A+1)(AB+B)+ABC+ABC^{-}+(AB+A)(AB+A^{-})$ 3

7. i) Draw R-S flip-flop. 2

ii) Draw the a) truth table, b) present state-next state table, c) excitation table, d) k map and

e) characteristic equation for this flip-flop. 2+2+2+2+2+2

ii) What is the meaning of "T" in T flip-flop? 1

iii) What is the advantage of J-K flip-flop over R-S flip-flop (Draw the truth tables for both)? 3

iv) What is the difference between sequential and combinational logic circuit? 2