HEAT TRANSFER

Introduction to the different modes

Ranjan Ganguly

Course Outcome (CO): At the end of the course the students will be able to

- **CO1:** Describe the primary modes of heat transfer and interpret the corresponding governing physics (**K2**)
- **CO2:** Develop the governing equations of heat transfer through conduction, convection and radiation in simple representative configurations (**K3**)
- **CO3:** Apply the relevant laws and correlations for solving heat transfer problems involving one or multiple modes of heat transfer (**K3**)
- **CO4:** Calculate performance of different heat transfer devices (**K4**)

Books:

1. **Fundamentals of Heat and Mass Transfer** by D. P. Dewitt and F..P. Incropera
 2. **Heat and Mass Transfer** by Y. Çengel
 3. **Heat Transfer** by N.A. Ozisik
-

Why study Heat Transfer?

- **Heat Transfer enhancement**

- Boiler, condenser, heat exchangers
- Electronic devices
- Electrical machines (transformers, generators, etc.)
- Cutting tools
- ...

- **Heat Transfer abatement**

- Turbine insulation
- Thermos
- Space station
- ...

- **Heat Transfer (& temperature) control**

- Chemical processes
 - Bio-heat transfer
 - ...
-

Difference between Thermodynamics & Heat Transfer

- **Heat:** Energy crossing the system boundary (energy in transit) due to temperature difference
- **Thermodynamics:**
 - How much heat is transferred (δQ , Q or dQ/dt)
 - How much work is done (δW , W or dW/dt)
 - Initial and final states of the system and the relation between heat and work
 - Predicts heat transfer under quasi-equilibrium condition
- **Heat Transfer:**
 - Deals with actual irreversible mode of heat transfer
 - At what rate the heat is transferred (dQ/dt)
 - What has led to the transfer of heat (temperature difference or gradient that has led to the heat transfer)
 - In what mode the heat is transferred (role of the medium)

Modes of Heat Transfer

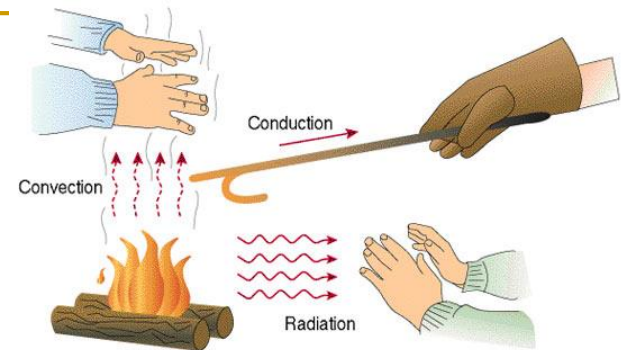

- **Conduction:** Transfer of heat from one part of a substance to another part of the same substance, or from one substance to another in physical contact with it, without any bulk displacement of the medium (media).
- **Convection:** Heat transfer that occurs between a surface and a fluid in motion) when they are at different temperatures (involves the combined effects of conduction and advection).
- **Radiation:** Heat transfer that occurs between two surfaces at different temperatures. It results from the energy emitted by any surface in the form of electromagnetic waves.

Actual heat transfer mostly combine all the modes

Conduction

Conduction: The transfer of energy from the more energetic particles of a substance to the adjacent less energetic ones as a result of interactions between the particles.

In gases and liquids, conduction is due to the collisions and diffusion of the molecules during their random motion.

In solids, it is due to the combination of vibrations of the molecules in a lattice and the energy transport by free electrons.

The rate of heat conduction through a plane layer is proportional to the temperature difference across the layer and the heat transfer area, but is inversely proportional to the thickness of the layer.

Rate of heat conduction $\propto \frac{(\text{Area})(\text{Temperature difference})}{\text{Thickness}}$

$$\dot{Q}_{\text{cond}} = kA \frac{T_1 - T_2}{\Delta x} = -kA \frac{\Delta T}{\Delta x} \quad (\text{W})$$

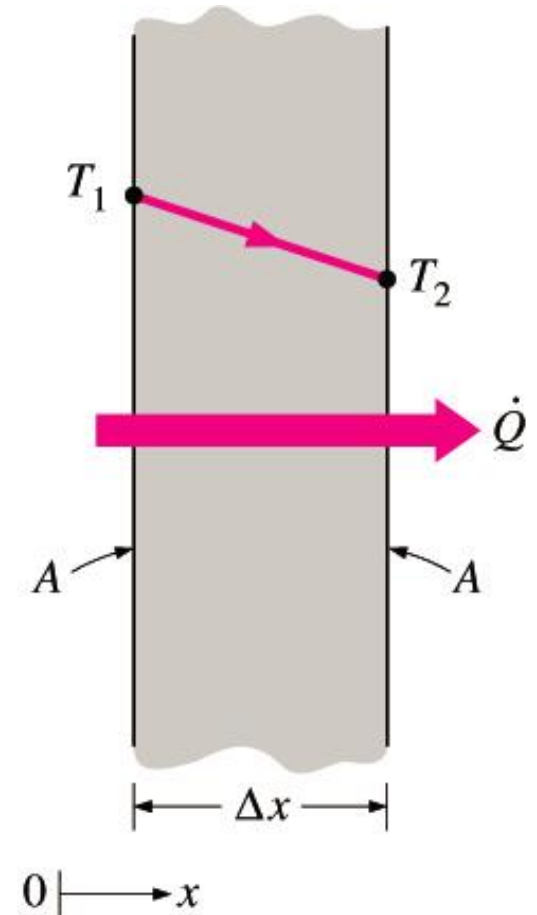

Heat conduction through a large plane wall of thickness Δx and area A .

Mode of thermal conduction

■ In solids:

- Lattice vibration
- Free Electrons

■ In liquids:

- Intermolecular collision
- Molecular diffusion

■ In gases

- Intermolecular collision
- Molecular diffusion

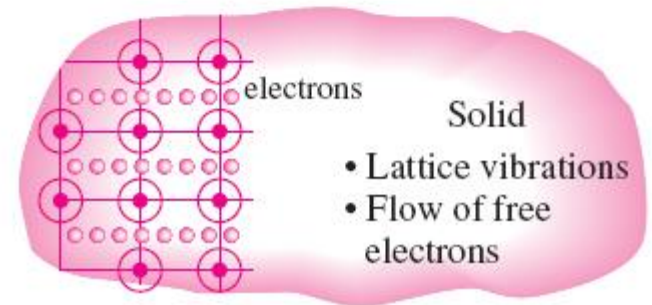
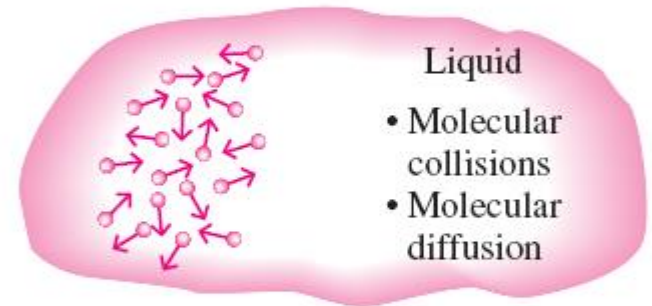
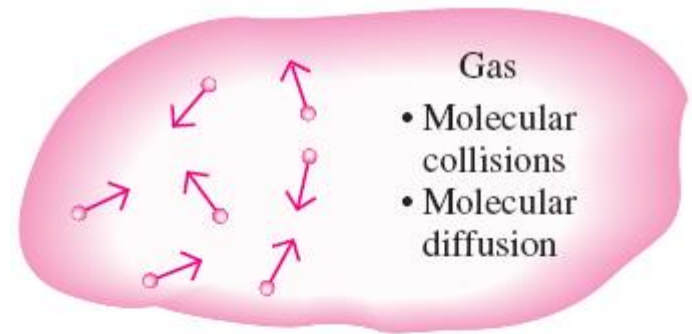

Fourier's Law of Heat Conduction

$$\dot{Q}_{\text{cond}} = -kA \frac{dT}{dx}$$

Thermal conductivity, k : A measure of the ability of a material to conduct heat. Evaluated as the rate of heat transfer through a unit thickness of the material per unit area per unit temperature difference **It is an intrinsic property of the medium (solid, liquid or gas)**

Temperature gradient dT/dx : The slope of the temperature curve on a T - x diagram.

Heat is conducted in the direction of decreasing temperature, and the temperature gradient becomes negative when temperature decreases with increasing x . The **negative sign** in the equation ensures that heat transfer in the positive x direction is a positive quantity.

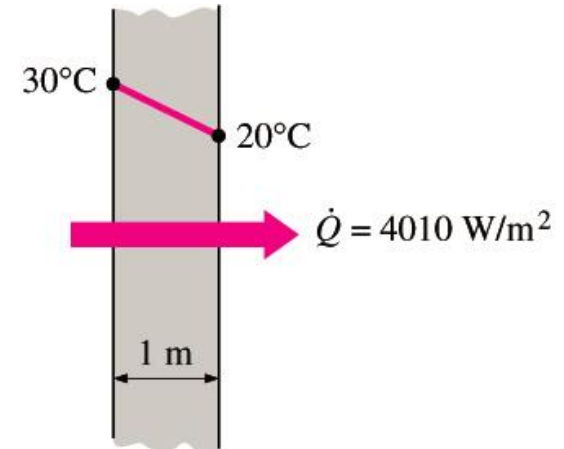

(a) Copper ($k = 401 \text{ W/m}\cdot\text{°C}$)

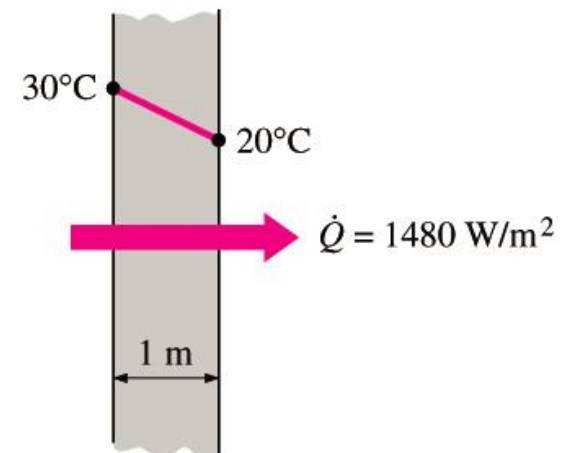

(b) Silicon ($k = 148 \text{ W/m}\cdot\text{°C}$)

Thermal conductivity

The thermal conductivities of some materials at room temperature

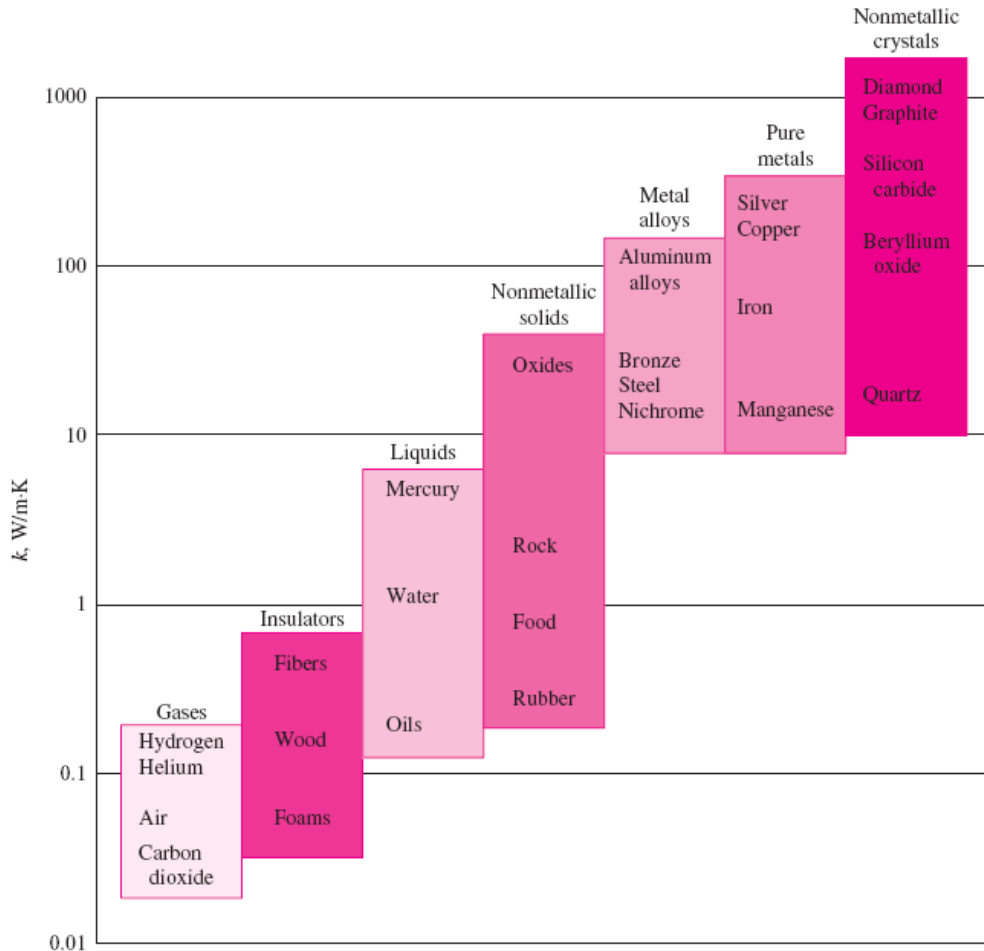

Material	k , W/m · °C*
Diamond	2300
Silver	429
Copper	401
Gold	317
Aluminum	237
Iron	80.2
Mercury (l)	8.54
Glass	0.78
Brick	0.72
Water (l)	0.607
Human skin	0.37
Wood (oak)	0.17
Helium (g)	0.152
Soft rubber	0.13
Glass fiber	0.043
Air (g)	0.026
Urethane, rigid foam	0.026

The range of thermal conductivity of various materials at room temperature.

Thermal Diffusivity

c_p **Specific heat, J/kg · °C:** Heat capacity per unit mass

ρc_p **Heat capacity, J/m³·°C:** Heat capacity per unit volume

α **Thermal diffusivity, m²/s:** Represents how fast heat diffuses through a material

$$\alpha = \frac{\text{Heat conduction}}{\text{Heat storage}} = \frac{k}{\rho c_p} \quad (\text{m}^2/\text{s})$$

A material that has a high thermal conductivity or a low heat capacity will obviously have a large thermal diffusivity.

The larger the thermal diffusivity, the faster the propagation of heat into the medium.

A small value of thermal diffusivity means that heat is mostly absorbed by the material and a small amount of heat is conducted further.

The thermal diffusivities of some materials at room temperature

Material	α , m ² /s*
Silver	149×10^{-6}
Gold	127×10^{-6}
Copper	113×10^{-6}
Aluminum	97.5×10^{-6}
Iron	22.8×10^{-6}
Mercury (l)	4.7×10^{-6}
Marble	1.2×10^{-6}
Ice	1.2×10^{-6}
Concrete	0.75×10^{-6}
Brick	0.52×10^{-6}
Heavy soil (dry)	0.52×10^{-6}
Glass	0.34×10^{-6}
Glass wool	0.23×10^{-6}
Water (l)	0.14×10^{-6}
Beef	0.14×10^{-6}
Wood (oak)	0.13×10^{-6}

Convection

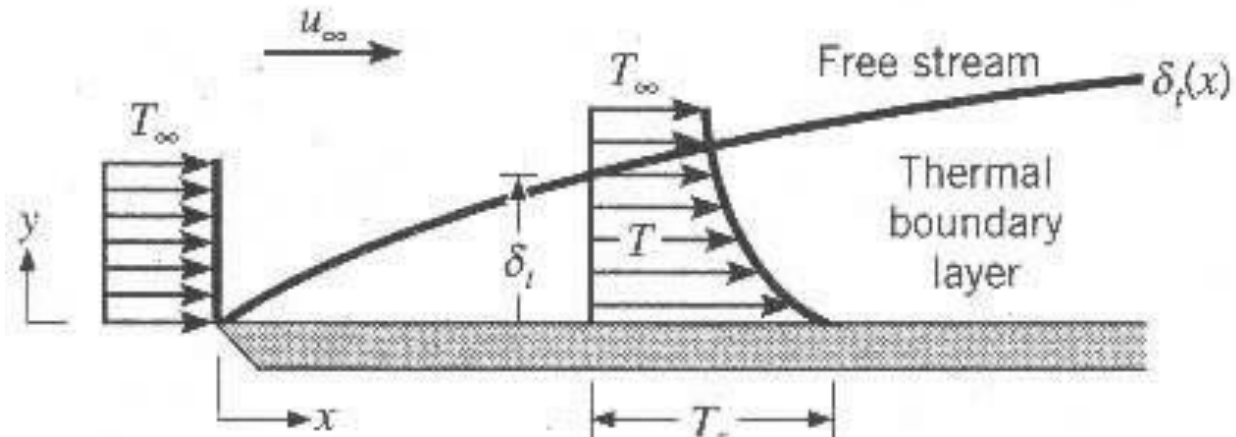
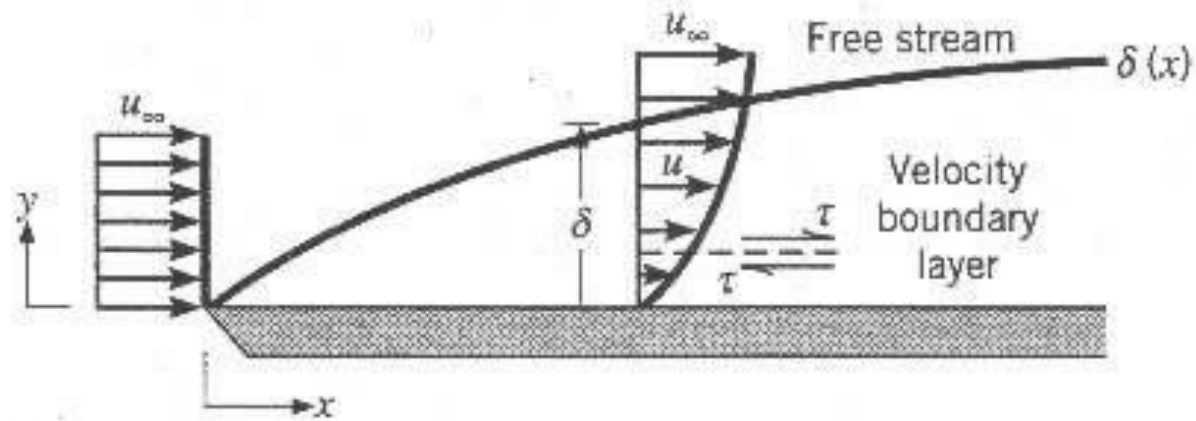

Convection

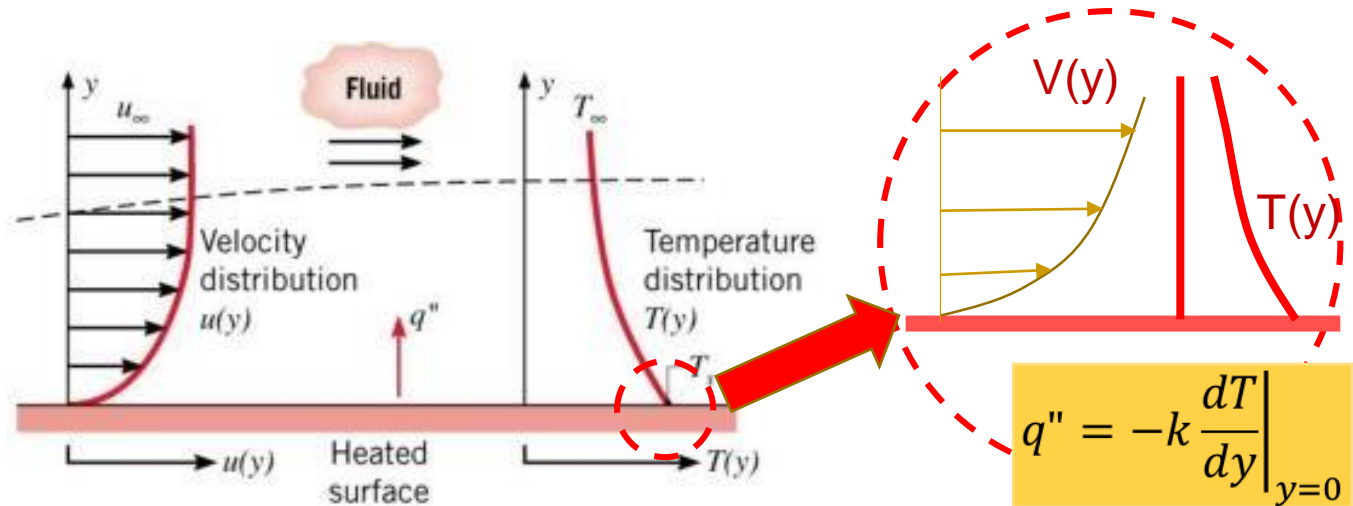

Newton's Law of Cooling

$$q'' = h(T_s - T_\infty) \quad [\text{W/m}^2]$$

$$\dot{Q}_{conv} = q'' \times A_s = Ah(T_s - T_\infty) \quad [\text{W}]$$

h = Heat transfer coefficient ($\text{W/m}^2\text{K}$)

A_s = Heat transfer surface area (m^2)

T_s = Surface temperature; T_∞ = Free-stream temperature (K)

Not a Law !

Heat transfer at the point of ZERO-SLIP takes place by pure conduction

Convection heat transfer coefficient

The convection heat transfer coefficient h is not a property of the fluid.

It is an experimentally determined parameter whose value depends on all the variables influencing convection such as

- the surface geometry
- the nature of fluid motion
- the properties of the fluid
- the bulk fluid velocity

Typical values of convection heat transfer coefficient

Type of convection	$h, \text{W/m}^2 \cdot ^\circ\text{C}^*$
Free convection of gases	2–25
Free convection of liquids	10–1000
Forced convection of gases	25–250
Forced convection of liquids	50–20,000
Boiling and condensation	2500–100,000

$$q'' = -k \left. \frac{dT}{dy} \right|_{y=0} = h(T_s - T_\infty)$$

Types of Convection

Forced convection: If the fluid is forced to flow over the surface by external means such as a fan, pump, or the wind.

Natural (or free) convection: If the fluid motion is caused by buoyancy forces that are induced by density differences due to the variation of temperature in the fluid.

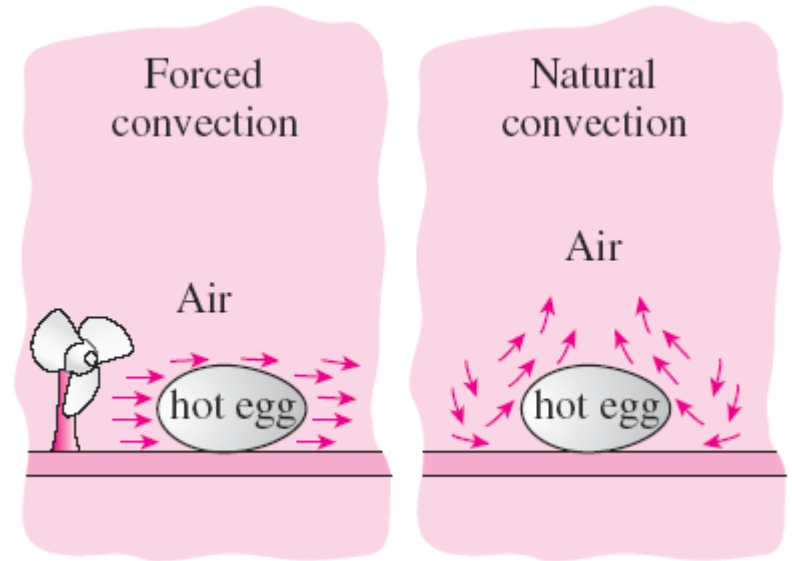

Thermal Radiation

- **Thermal Radiation:** The energy emitted by matter in the form of *electromagnetic waves* (or *photons*) as a result of the changes in the electronic configurations of the atoms or molecules within 0.1 – 100 μm wavelength
- Does not require the presence of an *intervening medium*.
- Occurs at the speed of light and suffers no attenuation in a vacuum.
- All bodies at a temperature above absolute zero emit thermal radiation.
- Radiation is a *volumetric phenomenon*, and all solids, liquids, and gases emit, absorb, or transmit radiation to varying degrees.
- However, radiation is usually considered to be a *surface phenomenon* for solids.

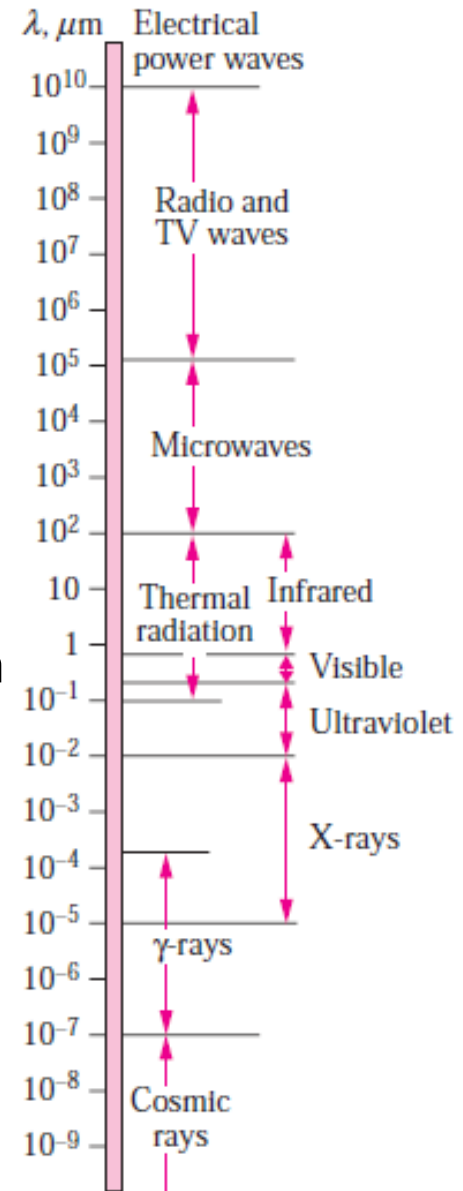

$$\dot{Q}_{\text{emit, max}} = \sigma A_s T_s^4 \quad (\text{W}) \quad \text{Stefan–Boltzmann law}$$

$$\sigma = 5.670 \times 10^{-8} \text{ W/m}^2 \cdot \text{K}^4 \quad \text{Stefan–Boltzmann constant}$$

Blackbody: The idealized surface that emits radiation at the maximum rate.

$$\dot{Q}_{\text{emit}} = \varepsilon \sigma A_s T_s^4 \quad (\text{W}) \quad \text{Radiation emitted by real surfaces}$$

Emissivity ε : A measure of how closely a surface approximates a blackbody for which $\varepsilon = 1$ of the surface. $0 \leq \varepsilon \leq 1$.

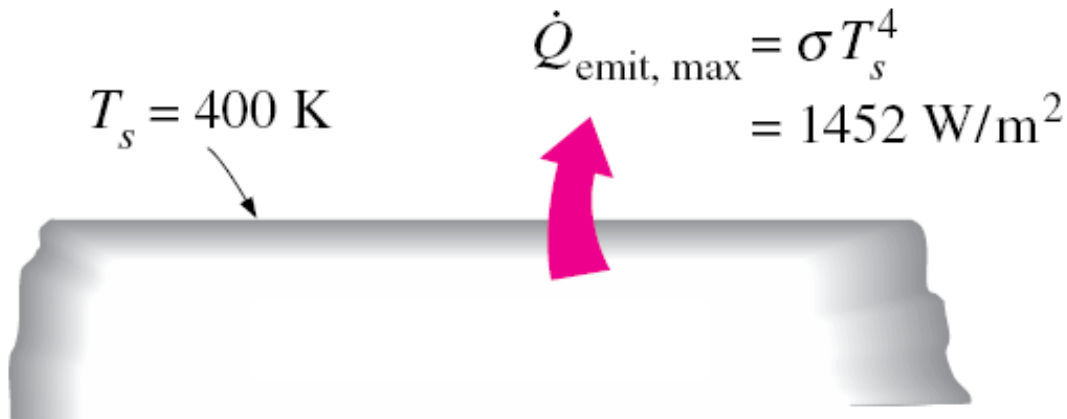

Emissivities of some materials at 300 K

Material	Emissivity
Aluminum foil	0.07
Anodized aluminum	0.82
Polished copper	0.03
Polished gold	0.03
Polished silver	0.02
Polished stainless steel	0.17
Black paint	0.98
White paint	0.90
White paper	0.92–0.97
Asphalt pavement	0.85–0.93
Red brick	0.93–0.96
Human skin	0.95
Wood	0.82–0.92
Soil	0.93–0.96
Water	0.96
Vegetation	0.92–0.96

Blackbody radiation: the *maximum amount of radiation that can be emitted from a surface at a specified temperature*

Absorptivity α : The fraction of the radiation energy incident on a surface that is absorbed by the surface. $0 \leq \alpha \leq 1$

A blackbody absorbs the entire radiation incident on it ($\alpha = 1$).

Kirchhoff's law: The emissivity and the absorptivity of a surface at a given temperature and wavelength are equal.

$$\dot{Q}_{\text{absorbed}} = \alpha \dot{Q}_{\text{incident}} \quad (\text{W})$$

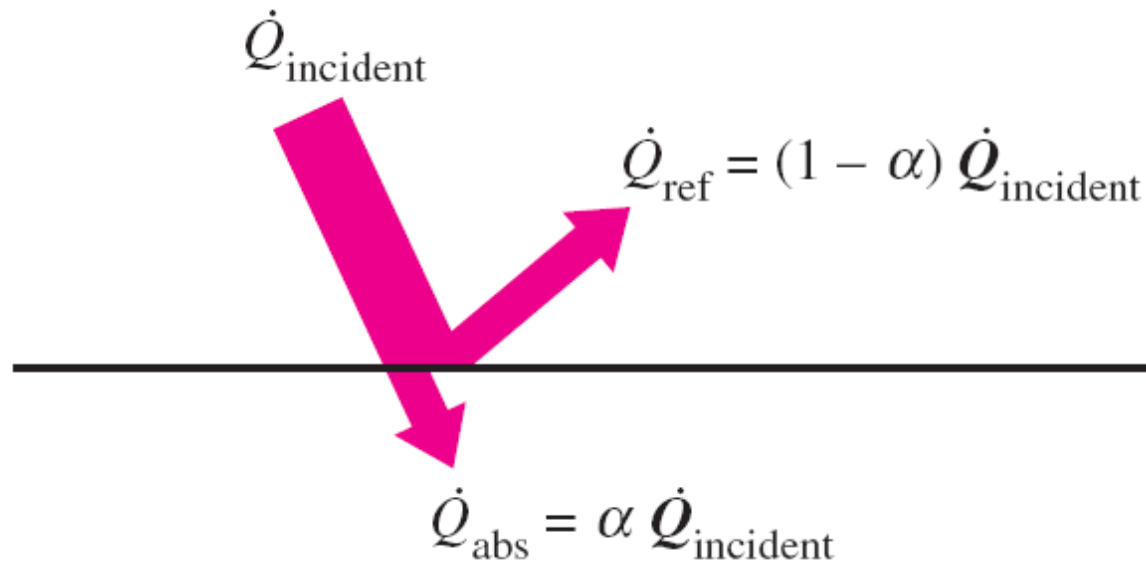

The absorption of radiation incident on an opaque surface of absorptivity .

Absorption and Emission of Radiation

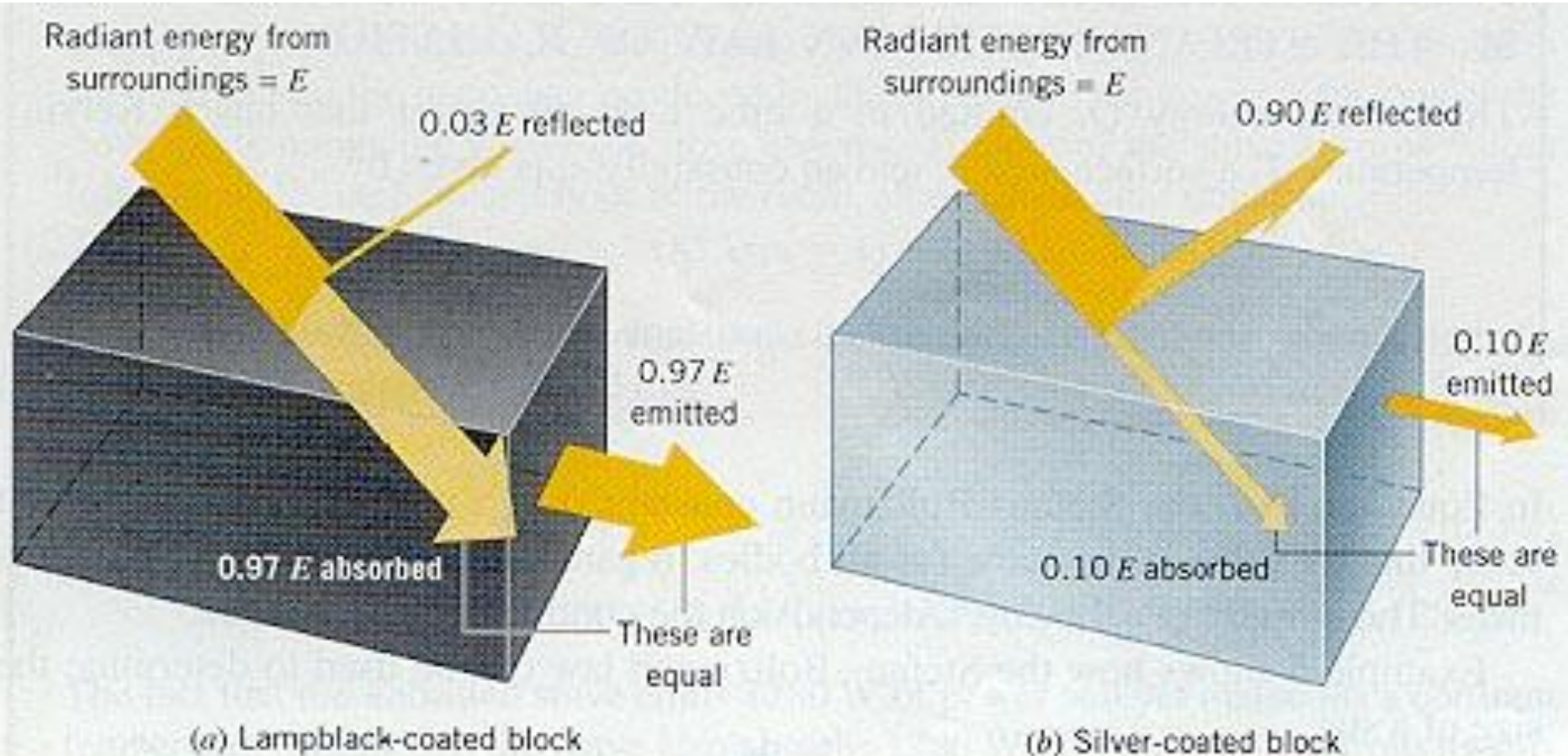

Energy out = Energy in
Emitted energy/Incident energy = Emissivity = ϵ .

Net radiation heat transfer:

The difference between the rates of radiation emitted by the surface and the radiation absorbed.

The determination of the net rate of heat transfer by radiation between two surfaces is a complicated matter since it depends on

- the properties of the surfaces
- their orientation relative to each other
- the interaction of the medium between the surfaces with radiation

Radiation is usually significant relative to conduction or natural convection, but negligible relative to forced convection.

When a surface is *completely enclosed* by a much larger (or black) surface at temperature T_{surr} separated by a gas (such as air) that does not intervene with radiation, the net rate of radiation heat transfer between these two surfaces is given by

$$\dot{Q}_{\text{rad}} = \varepsilon\sigma A_s (T_s^4 - T_{\text{surr}}^4) \quad (\text{W})$$

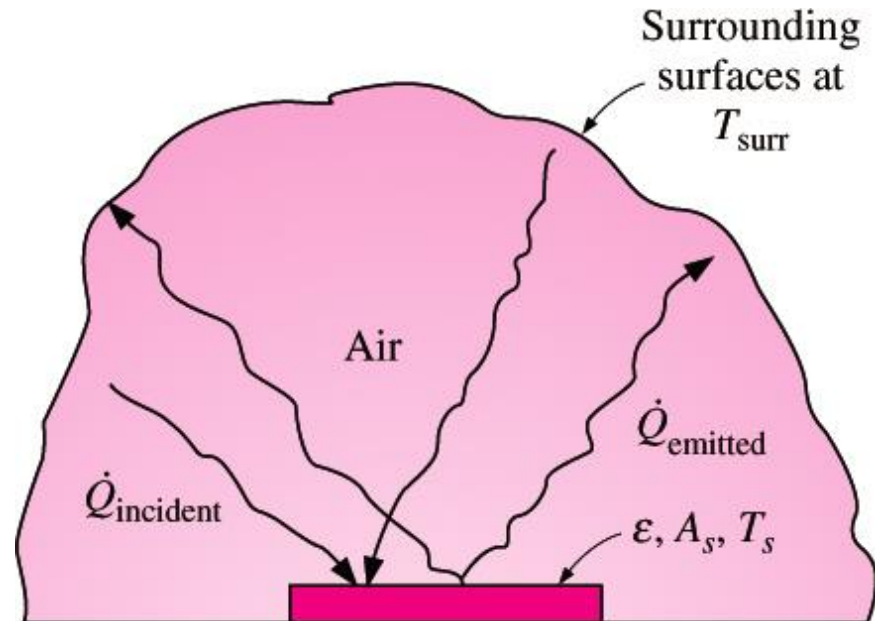

$$\dot{Q}_{\text{rad}} = \varepsilon\sigma A_s (T_s^4 - T_{\text{surr}}^4)$$

Radiation heat transfer between a surface and the surfaces surrounding it.

Simultaneous heat transfer mechanisms

- **Opaque solids:** By conduction
- **Transparent and semitransparent solids:** Conduction and radiation
- Heat transfer is by conduction and possibly by radiation in a *still fluid* (no bulk fluid motion) and by convection and radiation in a *flowing fluid*.
- In the absence of radiation, heat transfer through a fluid is either by conduction or convection, depending on the presence of any bulk fluid motion.
- Convection = Conduction + Advection (bulk flow)
- Heat transfer through a *vacuum* is by radiation.
- Most gases between two solid surfaces do not interfere with radiation.
- Liquids are usually strong absorbers of radiation.

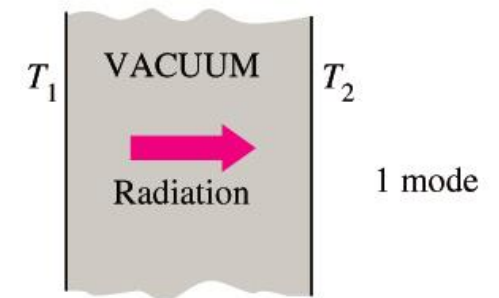
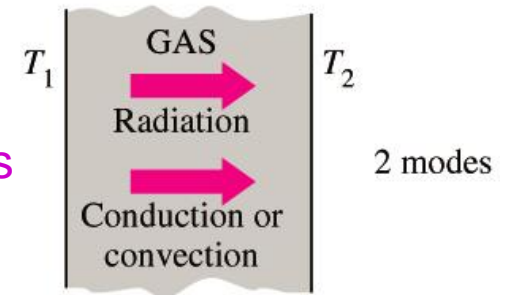
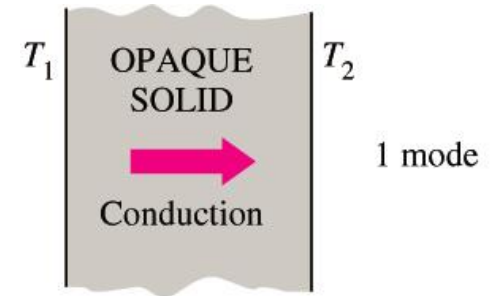

Although there are three mechanisms of heat transfer, a medium may involve only two of them simultaneously.

Combined Convection & Radiation

When radiation and convection occur simultaneously between a surface and a gas:

$$\dot{Q}_{\text{total}} = h_{\text{combined}} A_s (T_s - T_{\infty}) \quad (\text{W})$$

Combined heat transfer coefficient h_{combined}

Includes the effects of both convection and radiation

$$\dot{Q}_{\text{total}} = \dot{Q}_{\text{conv}} + \dot{Q}_{\text{rad}} = h_{\text{conv}} A_s (T_s - T_{\text{surr}}) + \varepsilon \sigma A_s (T_s^4 - T_{\text{surr}}^4)$$

$$\dot{Q}_{\text{total}} = h_{\text{combined}} A_s (T_s - T_{\infty}) \quad (\text{W})$$

$$h_{\text{combined}} = h_{\text{conv}} + h_{\text{rad}} = h_{\text{conv}} + \varepsilon \sigma (T_s + T_{\text{surr}})(T_s^2 + T_{\text{surr}}^2)$$

First Law of Thermodynamics

The **first law of thermodynamics (conservation of energy principle)** states that *energy can neither be created nor destroyed during a process; it can only change forms.*

$$\left(\begin{array}{c} \text{Total energy} \\ \text{entering the} \\ \text{system} \end{array} \right) - \left(\begin{array}{c} \text{Total energy} \\ \text{leaving the} \\ \text{system} \end{array} \right) = \left(\begin{array}{c} \text{Change in the} \\ \text{total energy of} \\ \text{the system} \end{array} \right)$$

$$\underbrace{E_{in} - E_{out}}_{\substack{\text{Net energy transfer} \\ \text{by heat, work, and mass}}} = \underbrace{\Delta E_{system}}_{\substack{\text{Change in internal, kinetic,} \\ \text{potential, etc., energies}}} \quad (J)$$

$$\underbrace{\dot{E}_{in} - \dot{E}_{out}}_{\substack{\text{Rate of net energy transfer} \\ \text{by heat, work, and mass}}} = \underbrace{dE_{system}/dt}_{\substack{\text{Rate of change in internal} \\ \text{kinetic, potential, etc., energies}}} \quad (W)$$

The net change (increase or decrease) in the total energy of the system during a process is equal to the difference between the total energy entering and the total energy leaving the system during that process.

The **energy balance** for any system undergoing any process in the rate form

For Closed System

$$\dot{Q} - \dot{W} = \left. \frac{dE}{dt} \right|_{CM}$$

For Open System

$$\dot{Q} - \dot{W} + \sum \dot{m}_{in} h_{in} - \sum \dot{m}_{out} h_{out} = \left. \frac{dE}{dt} \right|_{CV}$$

Examples

A plane wall 0.15 cm thick, of a homogeneous material with $k = 0.40 \text{ W/m}\cdot\text{K}$, has steady and uniform temperatures $T_1 = 20^\circ\text{C}$ and $T_2 = 70^\circ\text{C}$ (see Fig. 1-6). Determine the heat transfer rate in the positive x -direction per square meter of surface area.

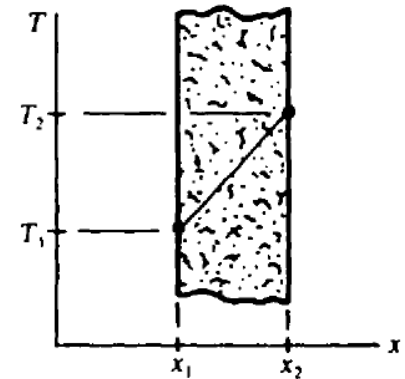

16-23 An aluminum pan whose thermal conductivity is $237 \text{ W/m}\cdot^\circ\text{C}$ has a flat bottom with diameter 20 cm and thickness 0.4 cm. Heat is transferred steadily to boiling water in the pan through its bottom at a rate of 800 W. If the inner surface of the bottom of the pan is at 105°C , determine the temperature of the outer surface of the bottom of the pan.

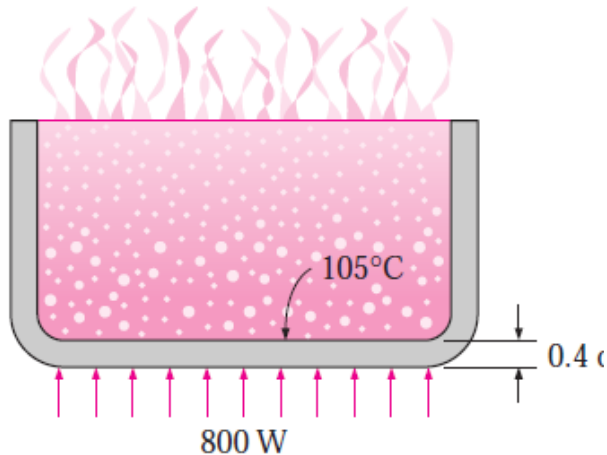

16-78 A 50-cm-long, 2-mm-diameter electric resistance wire submerged in water is used to determine the boiling heat transfer coefficient in water at 1 atm experimentally. The wire temperature is measured to be 130°C when a wattmeter indicates the electric power consumed to be 4.1 kW. Using Newton's law of cooling, determine the boiling heat transfer coefficient.

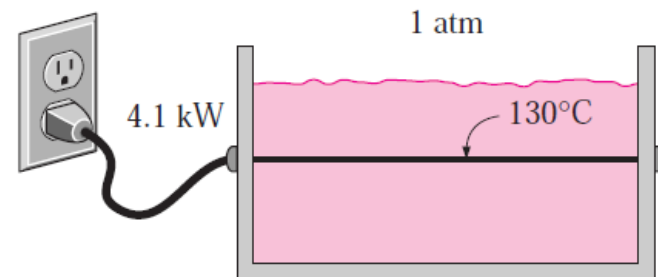

Example :

Consider a person standing in a breezy room at 20°C (both wall temperature and the air temperature). Determine the total rate of heat transfer from this person if the exposed surface area and the average outer surface temperature of the person are 1.6 m² and 29°C, respectively, and the convection heat transfer coefficient is 6 W/m²K.

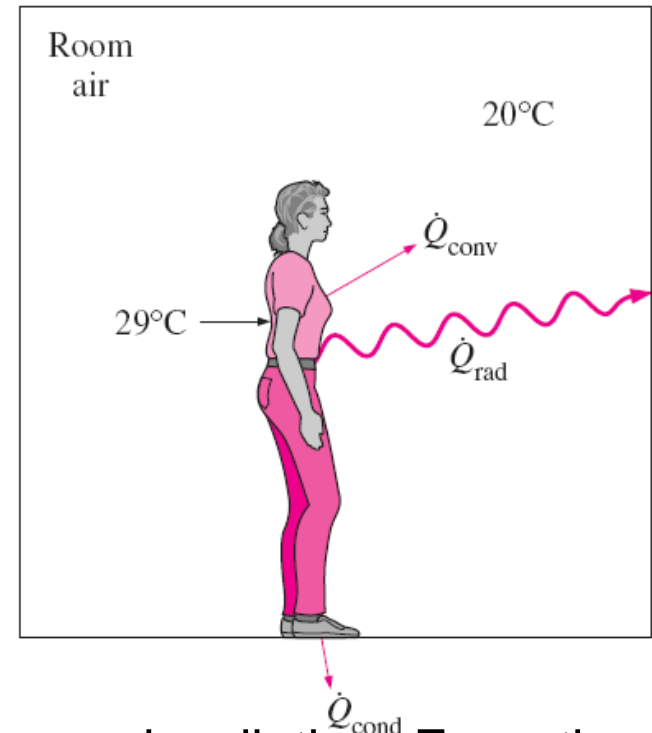

■ Solution :

Heat is transferred from the person by convection and radiation. From the above table the emissivity of human skin is 0.95,

$$\dot{Q}'_{\text{conv}} = hA_s(T_s - T_\infty) = 6 \frac{\text{W}}{\text{m}^2 \cdot ^\circ\text{C}} \times 1.6\text{m}^2 \times (29 - 20)^\circ\text{C} = 86.4\text{W}$$

$$\dot{Q}'_{\text{rad}} = \epsilon\sigma A_s(T_s^4 - T_{\text{surr}}^4)$$

$$= 0.95 \times 5.67 \times 10^{-8} \frac{\text{W}}{\text{m}^2 \cdot \text{K}^4} \times 1.6\text{m}^2 \times (302^4 - 293^4)\text{K}^4 = 81.7\text{W}$$

Examples

A 1000-W iron is left on the iron board with its base exposed to the air at 20°C . The convection heat transfer coefficient between the base surface and the surrounding air is $35\text{ W/m}^2\text{K}$. If the base has an emissivity of 0.6 and a surface area of 0.02 m^2 , determine the temperature of the base of the iron.

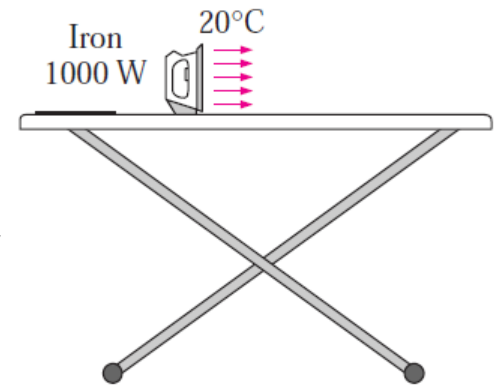

Ans: 674°C

Examples

A thin metal plate is insulated on the back and exposed to solar radiation on the front surface. The exposed surface of the plate has an emissivity and absorptivity of 0.7 for solar radiation. If solar radiation is incident on the plate at a rate of 700 W/m^2 and the surrounding air temperature is 10°C , **determine the surface temperature of the plate** under steady state. Take the convection heat transfer coefficient to be $30 \text{ W/m}^2 \text{ K}$, and (a) disregard any heat loss by radiation, (b) consider radiative heat loss to the surrounding that is also at 10°C

