

MASTER OF CIVIL ENGINEERING EXAMINATION 2025
(First Year, Second Semester)

RETAINING STRUCTURES & UNDERGROUND CONSTRUCTION

Time: Three Hours

Full Marks 100
(Part I: 40 Marks
Part II: 30 Marks
Part III: 30 Marks)

Use a separate Answer-Script for each part

Question No.	Part I (40 Marks)	Marks																																																	
<i>Answer any TWO questions from this Part. Assume reasonable values for the parameters, if not supplied.</i>																																																			
1	(a) What is called slope failure? Discuss about the factors affecting stability of a slope. (b) Define 'Long Term' and 'Short Term' stability checking of a slope. (c) What is residual shear strength of a soil sample? How it can be obtained? Which type of soil samples are normally considered for obtaining the residual strength? (d) Define pore water pressure and explain its importance.	1+9=10 2+2=4 1+2+1=4 2																																																	
2	(a) How an earthen slope may behave in gradual drawdown and sudden drawdown cases? (b) Distinguish between total stress and effective stress methods of slope stability analyses. (c) Indicate the shear strength parameters required for each type of analysis and how the same can be obtained? (d) Derive factor of safety of a reinforced slope extending the Bishop's method for slope stability analysis considering all forces on an elementary slice.	2 4 4 10																																																	
3	(a) Make a list of critical cases considered as per IS 7894, for stability analysis of any slope. (b) It is required to make a 5.0m deep cut in a c- ϕ soil. The slope is restricted to be 30° and the soil has $C_u = 2.4 \text{ t/m}^2$, $\phi = 7^\circ$ and $\gamma = 1.8 \text{ t/m}^2$. Find the factor of safety and estimate the critical height for the slope in this soil, using the following table for stability number.	5 9+6=15																																																	
<table border="1" style="margin: auto; border-collapse: collapse;"> <thead> <tr> <th style="width: 10%;">$\phi^\circ \backslash \beta^\circ$</th> <th style="width: 10%;">0</th> <th style="width: 10%;">5</th> <th style="width: 10%;">10</th> <th style="width: 10%;">15</th> <th style="width: 10%;">20</th> <th style="width: 10%;">25</th> </tr> </thead> <tbody> <tr> <td>90</td> <td>0.261</td> <td>0.239</td> <td>0.218</td> <td>0.199</td> <td>0.182</td> <td>0.166</td> </tr> <tr> <td>75</td> <td>0.219</td> <td>0.195</td> <td>0.193</td> <td>0.152</td> <td>0.134</td> <td>0.117</td> </tr> <tr> <td>60</td> <td>0.191</td> <td>0.162</td> <td>0.138</td> <td>0.116</td> <td>0.097</td> <td>0.079</td> </tr> <tr> <td>45</td> <td>0.170</td> <td>0.136</td> <td>0.108</td> <td>0.083</td> <td>0.062</td> <td>0.044</td> </tr> <tr> <td>30</td> <td>0.156</td> <td>0.110</td> <td>0.075</td> <td>0.046</td> <td>0.025</td> <td>0.009</td> </tr> <tr> <td>15</td> <td>0.145</td> <td>0.068</td> <td>0.023</td> <td>-</td> <td>-</td> <td>-</td> </tr> </tbody> </table>			$\phi^\circ \backslash \beta^\circ$	0	5	10	15	20	25	90	0.261	0.239	0.218	0.199	0.182	0.166	75	0.219	0.195	0.193	0.152	0.134	0.117	60	0.191	0.162	0.138	0.116	0.097	0.079	45	0.170	0.136	0.108	0.083	0.062	0.044	30	0.156	0.110	0.075	0.046	0.025	0.009	15	0.145	0.068	0.023	-	-	-
$\phi^\circ \backslash \beta^\circ$	0	5	10	15	20	25																																													
90	0.261	0.239	0.218	0.199	0.182	0.166																																													
75	0.219	0.195	0.193	0.152	0.134	0.117																																													
60	0.191	0.162	0.138	0.116	0.097	0.079																																													
45	0.170	0.136	0.108	0.083	0.062	0.044																																													
30	0.156	0.110	0.075	0.046	0.025	0.009																																													
15	0.145	0.068	0.023	-	-	-																																													

**M.E. CIVIL ENGINEERING FIRST YEAR
SECOND SEMESTER EXAM 2025**

SUBJECT: RETAINING STRUCTURES AND UNDERGROUND CONSTRUCTION
(Name in full)

**PAPER ××××
Part - II**

Marks =30

No. of
Question

CO Marks

- 1) Answer any one question from question number 1 or question number 2.
- 2) Assume reasonable values of data if it is not supplied,
- 3) There is no need of any code etc. for answering Part- II,
- 4) In the cases where excess number of questions will be answered exceeding the required number of question/s, the first required number of question/s will be evaluated only.

Sl. No.

Question

- 1 (a)** Discuss about the different types of sheeting and bracing systems. [NA] [10]
- (b)** Determine the loads in the three struts in Fig. 1. The Centre to Centre spacing of the struts along the length of the cut is 2.50 m. The soil is stiff, fissured clay ($\gamma = 18.5 \text{ kN/m}^3$, $c = 40 \text{ kN/m}^2$). Also determine the maximum bending moments in wales and sheet piles. [NA] [10]

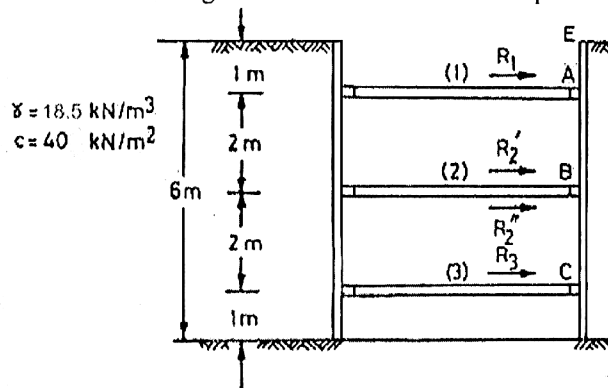

Fig.1

- 1 (c) (i)** Answer any one between 1 (c) to 1 (d) A counterfort wall of 10 m height retains noncohesive backfill. The void ratio $e = 0.67$ and $\phi = 30^\circ$ in loose state and $e = 0.45$ and $\phi = 40^\circ$ in dense state. Calculate and compare the active and passive earth pressure in both the cases. $G = 2.7$. Also comment on the result obtained. [NA] [5+5]
- (1) (c) (ii)** For the retaining wall shown in Fig. 2, plot the distribution of active earth pressure and determine the magnitude and point of application of the resultant active thrust.

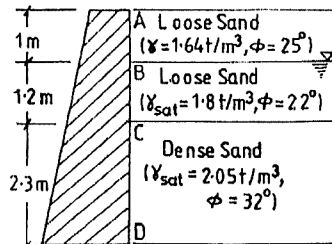

Fig.2

M.E. CIVIL ENGINEERING FIRST YEAR
SECOND SEMESTER EXAM 2025

SUBJECT: RETAINING STRUCTURES AND UNDERGROUND CONSTRUCTION
(Name in full)

PAPER ××××

Part - II

Marks =30

- (1) (d) (i) A 5 m high masonry retaining wall has to retain a backfill of sandy soil having unit weight $\gamma = 1.8 \text{ gm/cc}$ and an angle of internal friction of 30° . The surface of backfill is inclined at an angle of 9° to the horizontal. Determine the magnitude and point of application of active thrust from the wall. [NA] [5+5]
- (1) (d) (ii) A retaining wall of 5 m height has to retain a stratified backfill as shown in Fig. 3. Find out the magnitude of total active thrust on the wall and locate its point of application.

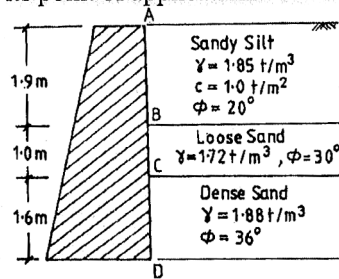

Fig.3

- Answer any one between 1 (e) to 1 (f)
- 1 (e) Explain the Coulomb's wedge theory along with the concerned assumptions. [NA] [10]
- (f) A wall of 5 m height retains a backfill of dry granular soil that has a level surface and weights 20 kN/m^3 . When there is no surcharge above the fill, the overturning moment caused by the total active pressure at a point at base of the wall is 120 kN-m/m length of the wall. The specification permits certain amount of uniformly distributed surcharge but state that surcharge must not increase the overturning moment by more than 50%. What surcharge can be allowed if angle of wall friction is 20° . [NA] [10]

- Answer any one between 2 (a) to 2 (b)
- 2 (a) Give brief explanations of design of various components of bracing (including the other criteria for design of braced cuts). [NA] [10]
- (b) Determine the forces in the struts for the bracing system shown in Fig. 4. Assume hinges at levels B, C, and D. Take $\gamma = 18.2 \text{ kN/m}^3$, $c = 32 \text{ kN/m}^2$ and $s = 2.0 \text{ m}$. [NA] [10]

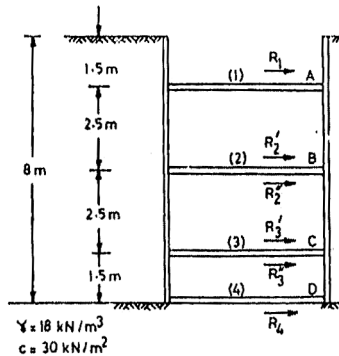

Fig.4

**M.E. CIVIL ENGINEERING FIRST YEAR
SECOND SEMESTER EXAM 2025**

SUBJECT: RETAINING STRUCTURES AND UNDERGROUND CONSTRUCTION
(Name in full)

PAPER ××××

Part - II

Marks =30

Answer any one between 2 (c) to 2 (d)

- 2 (c) Discuss Effect of wall movements on earth pressure. [NA] [10]
(d) Explain the Rankine earth pressure theory of lateral earth pressure. [NA] [10]

Answer any one between 2 (e) to 2 (f)

- 2 (e) Briefly mention about the various types of underground conduits which are generally constructed. What is imperfect ditch conduit? - explain. [NA] [5+5]
(f) Write notes on: [NA] [5+5]
i) loads on conduits due to surface loads.
ii) Construction of conduits.

End of Questions

**M. E. CIVIL ENGINEERING FIRST YEAR SECOND SEMESTER
EXAM – 2025**

RETAINING STRUCTURES AND UNDERGROUND CONSTRUCTION (PART-III)

TIME: Three Hours

FULL MARKS: 100 (40+30+30)

*Answer all the questions
Assume any data if needed, reasonably*

1. Calculate the embedment depth (D) of the sheet pile shown in the figure. [15]

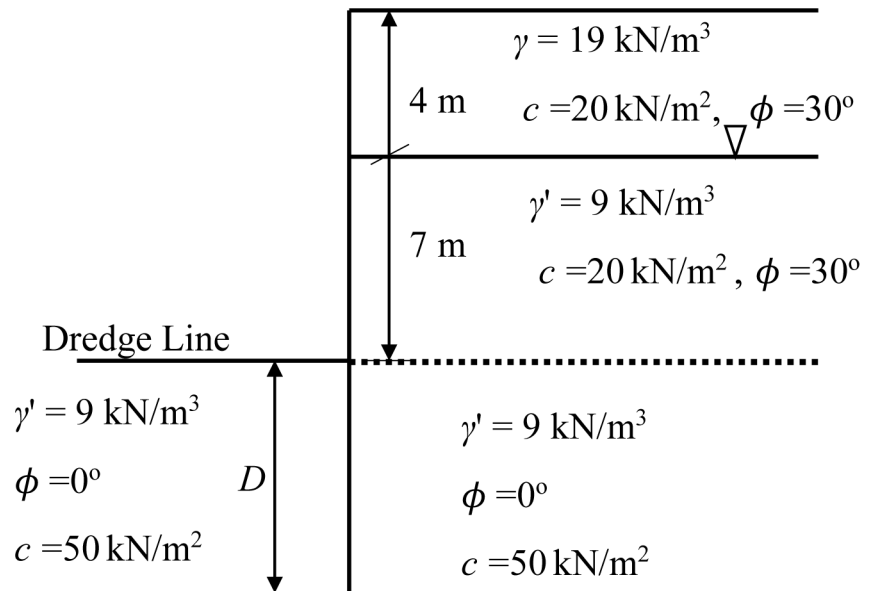

2. Explain the process of designing the anchor bulkhead both for continuous and discontinuous case. [10]
3. Discuss differences and advantages of various types of cellular cofferdams. [5]