

**FEASIBILITY AND PERFORMANCE
ANALYSIS OF MICROCHANNEL-TEXTURED
CUTTING TOOLS FOR ENHANCED
MACHINABILITY IN METAL CUTTING
APPLICATIONS**

Thesis Submitted by
Arindam Santra

DOCTOR OF PHILOSOPHY (ENGINEERING)

**Department of Mechanical Engineering
Faculty Council of Engineering & Technology
Jadavpur University
Kolkata, India**

2025

**JADAVPUR UNIVERSITY
KOLKATA- 700032**

INDEX NO. 273/18/E

1. Title of the thesis:

**FEASIBILITY AND PERFORMANCE ANALYSIS OF
MICROCHANNEL-TEXTURED CUTTING TOOLS FOR ENHANCED
MACHINABILITY IN METAL CUTTING APPLICATIONS**

2. Name, Designation & Institution of the Supervisors:

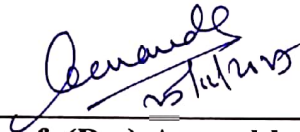

Prof. (Dr.) Arunabha Chanda

Professor

Department of Mechanical Engineering

Jadavpur University

Kolkata-700032, India

Professor

*Dept. of Mechanical Engineering
Jadavpur University, Kolkata-32*

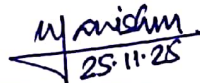

Dr. Manish Mukhopadhyay

Assistant Professor

Department of Mechanical Engineering

Meghnad Saha Institute of Technology,

Kolkata-700150, India

*Head of the Department
Mechanical Engineering Department
Meghnad Saha Institute of Technology*



3. List of Publications:

Journal Publications (2)

1. Santra, A., Mukhopadhyay, M. and Chanda, A., 2024. Microchannel engrooved carbide tool rake: a feasibility study for machining Ti-6Al-4V. *Sādhanā*, 49(4), p.283.
2. Santra, A., Mukhopadhyay, M. and Chanda, A., 2023. Estimating Tool Strength of Single Point Cutting Tool with Engrooved Micro-Channel on Rake Face: An Experimental Assisted Simulative Analysis. *Journal of The Institution of Engineers (India): Series C*, 104(5), pp.1011-1021.

Conference Publications (2)

1. Santra, M. Mukhopadhyay, A. Chanda, in 41st International *MATADOR* Conference on Advanced Manufacturing. Manchester, UK. (2021)
2. Santra, A., Bose, A. and Chanda, A., 2021. Numerical Investigation on Performance Enhancement of Rectangular Microchannel by Using Quadrilateral Fins Embedded on the Channel Bed. In Theoretical, Computational, and Experimental Solutions to Thermo-Fluid Systems: Select Proceedings of *ICITFES 2020* (pp. 391-399). Springer Singapore.

4. List of Patents: NIL

5. List of Presentations in National/International Conferences:

1. Santra, M. Mukhopadhyay, A. Chanda, in 41st International *MATADOR* Conference on Advanced Manufacturing. Manchester, UK. (2021)
2. Santra, A., Bose, A. and Chanda, A., 2021. Numerical Investigation on Performance Enhancement of Rectangular Microchannel by Using Quadrilateral Fins Embedded on the Channel Bed. In Theoretical, Computational, and Experimental Solutions to Thermo-Fluid Systems: Select Proceedings of *ICITFES 2020* (pp. 391-399). Springer Singapore.

“Statement of Originality”

I, Arindam Santra, registered on 22nd May, 2018, do hereby declared that the thesis entitled “*Feasibility and Performance Analysis of Microchannel-Textured Cutting Tools for Enhanced Machinability in Metal Cutting Applications*” contains literature survey and original research work done by undersigned candidates as part of Doctoral studies.

All information in this thesis have been obtained and presented in accordance with existing academic rules and ethical conduct. I declare that, as required by these rules and conduct, I have fully cited and referred all materials and results that are not original to this work.

I also declared that I have checked this thesis as per the “Policy on Anti Plagiarism, Jadavpur University, 2019”, and the level of similarity as checked by iThenticate software is 3 %.

Arindam Santra

Signature of Candidate:

Date: 25/11/2025

Debnath
25/11/2025

Certified by Supervisor:
(Signature with date, seal)

Professor

Dept. of Mechanical Engineering
Jadavpur University, Kolkata-32

Manish
25.11.25

Certified by Supervisor:
(Signature with date, seal)

Head of the Department
Mechanical Engineering Department
Meghnad Saha Institute of Technology

CERTIFICATE FROM THE SUPERVISORS

This is to certify that the thesis entitled “**Feasibility and Performance Analysis of Microchannel-Textured Cutting Tools for Enhanced Machinability in Metal Cutting Applications**” submitted by Sri. Arindam Santra, who got his name registered on **22.05.2018 [D-7/E/252/18]** for the award of Ph.D. (Engg.) degree of Jadavpur University is absolutely based upon his own work under the supervision of **Prof. Arunabha Chanda** and **Prof. Manish Mukhopadhyay** and that neither his thesis nor any part of the thesis has been submitted for any degree/ diploma or any other academic award anywhere before.

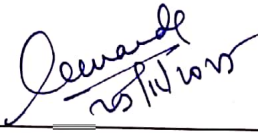

[Prof. (Dr.) Arunabha Chanda]
Signature of Supervisor
Date with Office seal

Professor
Dept. of Mechanical Engineering
Jadavpur University, Kolkata-32

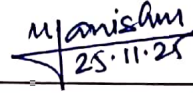

[Dr. Manish Mukhopadhyay]
Signature of Supervisor
Date with Office seal

Head of the Department
Mechanical Engineering Department
Meghnad Saha Institute of Technology

Dedicated To

My Grand Parents

For their heavenly blessings,

My Parents and My family

For their constant support,

cooperation and sacrifice.

ACKNOWLEDGEMENTS

I take this opportunity to convey my sincere regards, deepest respect and inmost gratitude to my supervisors Dr. Arunabha Chanda and Dr. Manish Mukhopadhyay for introducing me in the challenging filed of feasibility study of Microchannel engrooved cutting tool with his constructive guidance, precious advices and ceaseless encouragement during the stint of my research work. They are the incarnation of knowledge and wisdom, intellect, sincerity, insistence, inventiveness and tranquility. Apart from the field of academics, they are good human being and I was thoroughly impressed by their cooperative behaviour and ever-motivating attitude. They are the greatest sources of inspiration to me and I have tried to imbibe such rare qualities. I am fortunate enough to work under the guidance of such an outstanding teacher cum researchers. To me, my supervisors are the benchmark of academic as well as of research excellence. Their effort towards academics will always motivate me to work hard and propel me to move forward in the pursuit of academic excellence in the years to come. They have indeed helped me to grow as an individual having ethics and pride in whatever work I may indulge in.

Words are inadequate in offering my thanks to Dr. Pranab Kundu, Ex. Assistant Professor, Department of Mechanical Engineering, MNIT, Allahabad, for providing me necessary facilities to carry out my experimentations and for offering kind co-operation and help in every manner as and when required and providing lots of valuable suggestions.

I would like to offer a sincere thankfulness to Department of Mechanical Engineering, Meghnad Saha Institute of Technology, Kolkata for allowing me to use their facilities. The quality of the work would not have been possible without it.

I am also thankful to all the faculty members of department of Mechanical Engineering, Meghnad Saha Institute of Technology, Kolkata specially Mr. Anirban Bose, Mr. Santanu Bandyopadyay, Dr. Tapobrata Bhattacharya, Mr. Goutam Laha and Mr. Dibakar Ghosh for helping me a lot whenever asked for.

In the entire course of my work towards the development of this thesis there have been many a person whom I would like to extend my thankfulness. Among them Mr. Jayanta Sarkar, Mr. Koushik Halder, Mr. Bibhas Bhandari, and Mr. Debraj Shaw deserve special thanks. They have been more than friends for me and have always helped me in every manner.

A very special thanks to the HOD, Mechanical Engineering Department and the Vice-Chancellor, Jadavpur University for allowing me to access different facilities for completion of the work.

I would like to sincerely acknowledge the unwavering support of my family throughout the course of my PhD. I am deeply grateful to my father and mother for their enduring guidance and values, to my wife for her constant support and patience, to my son whose presence kept me joyful even under stressful conditions, and to my younger brother for his steady encouragement during this journey.

November 2025

Jadavpur University
Kolkata -700032

Arindam Santra

(Arindam Santra)

ABSTRACT

The increasing industrial emphasis on sustainable and high-efficiency manufacturing has necessitated the evolution of novel cooling methodologies that minimize coolant usage while maintaining or enhancing the machining performance of cutting tools. Traditional flood cooling methods, while effective in dissipating heat, are associated with significant operational costs, environmental concerns, and limited efficiency, particularly when machining low thermal conductivity materials such as titanium alloys. One of the principal challenges in machining operations lies in ensuring adequate penetration of the cutting fluid into the plastic contact (Cp) region—an intense heat generation zone formed due to plastic deformation and friction at the tool-workpiece interface. Inadequate thermal management in this region often leads to accelerated tool wear, dimensional inaccuracies, and poor surface integrity of the machined component.

Drawing inspiration from the thermal management capabilities of microchannel heat sinks used in electronic and aerospace applications, this research investigates the feasibility and performance enhancement potential of microchannel-textured cutting tools. The study is structured into four integral phases encompassing both numerical and experimental approaches. Initially, a numerical modelling scheme based on Finite Element Analysis (FEA) is developed and validated against experimental cutting force data using high-speed steel (HSS) tools in the machining of mild steel. The structural integrity of cutting tools integrated with various microchannel geometries—rectangular, semi-circular, trapezoidal, and V-shaped—is evaluated under simulated cutting loads. The validated models incorporate maximum principal stress (MPS) criteria to predict stress distributions and identify optimal microchannel configurations.

The second phase examines the performance of HSS tools with single and double microchannel designs positioned at varying proximities (0.5 mm to 2 mm) from the principal cutting edge (PCE). Simulation results indicate that trapezoidal and semi-circular microchannels positioned at or beyond 1.25 mm from the PCE provide superior stress mitigation and thermal regulation, without exceeding the material's yield strength. Subsequently, the analysis is extended to uncoated tungsten carbide (WC-Co) tools used for machining Ti-6Al-4V—a difficult-to-machine alloy characterized by high strength-to-weight ratio and poor thermal conductivity. A comprehensive structural analysis under static loads derived from literature and prior studies

reveals that microchannel-induced stress increments remain within the safe operational limits of the tool material, with trapezoidal geometries again outperforming other shapes in terms of mechanical resilience and thermal efficiency.

The final phase involves experimental validation through turning operations on mild steel using M42 grade HSS cutting tools integrated with laser-engraved microchannels. Two distinct trapezoidal microchannel configurations are examined under dry, small quantity lubrication (SQL), and microchannel-assisted cooling conditions. Cutting forces are measured via strain-gauge dynamometry, temperature distribution is recorded using infrared thermography, and surface finish is assessed with a stylus profilometer. Results consistently demonstrate that microchannel-integrated tools significantly reduce cutting and feed forces, suppress peak temperatures in the cutting zone, and yield superior surface finish compared to conventional cooling strategies. The performance enhancements are attributed to improved fluid penetration into the Cp region, enhanced convective heat transfer, and localized capillary-driven fluid flow within the channels.

In summary, this research confirms the technical feasibility and functional advantages of incorporating microchannels into cutting tools. The proposed design methodology ensures a balance between structural integrity and thermal performance, thereby presenting a viable pathway for the development of next-generation tooling systems. These findings hold considerable potential for extending tool life, improving machinability of advanced materials, and contributing to the realization of environmentally sustainable machining practices.

CONTENTS

Title Page	i
Statement of Originality	iv
Certificate from the supervisors	v
Acknowledgements	vii
Abstract	ix
Contents	xi
List of Tables	xiv
List of Figures	xiv
List of symbols and abbreviations	xvi
Chapter 1 Introduction to Machining and It's Challenges	1
1. Introduction	3
1.1 History of machining	3
1.2 Literature Review: Challenges in Conventional Machining Processes	5
Chapter 2 Literature review and Objective of the present work	13
2. Introduction	15
2.1 Flood Cooling	15
2.1.1 Advantages of Flood Cooling	15
2.1.2 Drawbacks of Flood Cooling	19
2.2 Minimum Quantity Lubrication Method	22
2.3 Cryogenic Cooling Method	30
2.3.1 Advantages of Cryogenic Cooling Method	30

2.3.2 Drawbacks of Cryogenic Cooling	31
2.4 Microchannel Heat Sink	33
2.5 Integration of Microchannel heat sink in Machining	41
2.6 Identified Research Gap	45
2.7 Objective of the Study	46
Chapter 3	Materials and Methods
	49
3. Introduction	51
3.1 Numerical Model Validation.	53
3.2 Methodology for Evaluating Structural Integrity of Microchannel Engraved HSS Cutting Tools in Mild Steel Machining.	55
3.3 Simulation Strategy for Uncoated WC Tools with Microchannels in Machining of Ti-6Al-4V.	61
3.4 Integrated Experimental and Simulation Approach for Validating Optimized Tool Microchannel Designs.	68
Chapter 4	Results and Discussions
	73
4.1 Introduction	75
4.2 Validation of the Numerical Modelling Scheme for Detailed Analysis	75
4.3 Feasibility Analysis of Microchannel engraved HSS Cutting Tools for Machining Mild Steel	77
4.4 Feasibility Analysis of Microchannel engraved Tungsten Carbide (WC) Cutting Tools with Microchannels for Machining Ti-6Al-4V	83
4.5 Experimental Validation of the Proposed Cutting Tool Model	87

Chapter 5	Conclusions and Scope of Future Work	93
	5.1 Conclusions	95
	5.2 Scope of Future Work	97
References		98

List of Tables

Table 1.1: Challenges in Conventional Machining

Table 3.1: Details of the study

Table 3.2: Elaboration of the study

Table 3.3: Experimental study details

List of Figures

Figure 2.1: Cutting fluid action in machining

Figure 3.2.1: Flowchart of the study

Figure 3.2.2: Geometry of the cutting tool

Figure 3.2.3: Final mesh of the cutting tool

Figure 3.2.4: Result of the grid independence test

Figure 3.2.5: Boundary conditions of numerical simulations and the geometrical specifications of the microchannels

Figure 3.3.1 (a): Result of numerical study utilizing the force components leading to the failure of the cutting tool

Figure 3.3.1 (b): Comparative analysis between Simulated Maximum Principal stress and Ultimate Tensile Strength of cutting tool material

Figure 3.3.2 (a): Study Flow Diagram

Figure 3.3.2 (b): Tool Geometry

Figure 3.3.2 (c): Mesh geometry of the cutting tool

Figure 3.3.2 (d): Grid independence assessment

Figure 3.3.3: Cross section of different microchannels and 2D profile of a single microchannel positioned 1 mm from PCE & 0.5 mm from ACE

Figure 3.4.1 (a): Tool with micro-channel

Figure 3.4.1 (b): Laser engraving machine

Figure 3.4.2: Geometry of Microchannel

Figure 3.4.3: Grid Independence test results

Figure 4.2.1. Result of simulative analysis using the force components under which the cutting tool failed

Figure 4.2.2: Comparison of simulated maximum principal stress and UTS of cutting tool material

Figure 4.3.1: Result of simulative analysis for different shaped microchannel positioned at various proximity from PCE

Figure 4.3.2: Variation of maximum principal stress for single microchannel under varying proximity to PCE (datum level for maximum principal stress is 8.0E+01 MPa)

Figure 4.3.3: Result of simulative analysis for different shaped multi microchannel positioned at various proximity from PCE

Figure 4.3.4: Variation of maximum principal stress for multi microchannel under varying proximity to PCE (datum level for maximum principal stress is 8.0E+01 MPa)

Figure 4.4.1: Maximum Principal Stress (MPa) for cutting tool having microchannel positioned at various proximity from PCE

Figure 4.4.2: Fluctuation of maximum principal stress for single microchannel in relation to varying proximity to PCE (reference level for maximum principal stress is 1000 MPa)

Figure 4.4.3: Result of Maximum Total Deformation (mm) for cutting tool having microchannel positioned at various proximity from PCE

Figure 4.4.4: Variation of maximum total deformation under varying proximity to PCE (datum level for Maximum Total Deformation is 6.04E-06 mm)

Figure 4.5.1: Comparison of cutting force (P_z)

Figure 4.5.2: Comparison of Feed force (P_f) and Thrust force (P_t)

Figure 4.5.3: Variation of temperature with spindle speed in different environments

Figure 4.5.4: Variation of average surface roughness with spindle speed in different environments

Figure 4.5.5: SEM micrographs of cutting tools under various cutting condition (spindle speed 420 rpm) (a) Dry (b) SQL (c) MC (Case 1) (d) MC (case 2)

Figure 4.5.6: Maximum Principal Stress (MPa) contour for Case 1 & Case 2

List of symbols and abbreviations

ACE	Auxiliary cutting edge
C _p	Plastic contact region
CVD	Chemical vapor deposition
DBD	Drop by drop
DRC	Double-row ribbed channels
DTM	Difficult to machine
HSS	High speed steel
LFHV	Low flow high velocity
MCHS	Microchannel heat sinks
MPS	Maximum principal stress
MQL	Minimum quantity lubrication
MWCNT	Multi-walled carbon nanotube
PCE	Principal cutting edge
P _f	Feed force
P _t	Thrust force
PVD	Physical vapor deposition
P _z	Cutting force
SPTT	Single point turning tool
SQL	Small quantity lubrication
SRC	Single-row ribbed channels
SRR	Slant rectangular ribs
SWR	Side wall ribs
UTS (σ_{ut})	Ultimate tensile strength
WC/Co	Uncoated tungsten carbide

Chapter 1:

Introduction to Machining and It's Challenges

1. Introduction

Machining constitutes a quintessential manufacturing procedure in which a precisely honed cutting instrument is utilized to remove material, thereby configuring the workpiece into the requisite geometric form. The procedure fundamentally entails the shear-induced deformation in the material leading to chip formation, with the elimination of this material segment revealing a novel substrate layer. Although machining is predominantly employed for the shaping of metals, it necessitates a relative motion between the workpiece and the cutting tool. This relative motion is facilitated by a principal cutting velocity accompanied by a secondary feed movement. The morphology of the cutting tool and its penetration into the workpiece material substrate, together with these motions, are instrumental in ascertaining the final geometry of the work surface.

1.1. History of Machining

Machining, an essential element of contemporary manufacturing, has progressed from basic manual methods to a highly advanced field grounded in scientific principles and technological advancements. The inception of material removal techniques can be traced back to prehistoric eras, when early humans employed rudimentary tools to sculpt wood and shape stones, thereby establishing the foundation for tool-making. Artifacts from ancient civilizations, including the utilization of rotating bowstring mechanisms by the Egyptians for drilling purposes, underscore the creativity and early progress of machining methodologies.

The Industrial Revolution represented a pivotal era that spurred the methodical advancement of machine tool technology. Between 1770 and 1850, noteworthy innovations laid the groundwork for traditional machining operations such as turning, boring, milling, drilling, and shaping. The progression of contemporary machine tools is profoundly intertwined with the technological breakthroughs of the Industrial Revolution. In 1763, James Watt faced a significant engineering obstacle while designing his steam engine: achieving the exact cylinder bore dimensions required to avert steam leakage around the piston. This issue was adeptly resolved in 1775 through John Wilkinson's creation of a water-wheel-powered boring machine, which offered the necessary precision for fabricating components of Watt's steam engine.

Circa 1800, Henry Maudsley transformed machining practices with his screw-cutting lathe, integrating mechanized tool carriages to realize exceptional accuracy in threading and feeding operations. Likewise, Eli Whitney's invention of the milling machine in 1818 represented a substantial advancement in machining capabilities, while the emergence of planers and shapers met industrial requirements for precision components in steam engines and textile machinery. Approximately in 1846, James Nasmyth's powered drill press facilitated accurate hole drilling in metal, signifying a remarkable progression in machining technology.

By the mid-19th century, the foundational configurations of machine tools, including lathes, milling machines, planers, and drill presses, had been firmly established, thereby constituting the essential framework of modern machining methodologies. The subsequent significant advancement transpired during the late 1950s with the emergence of machining centers, which amalgamated various cutting processes into a singular machine tool. This transformation was propelled by the innovation of numerical control (NC), a technological advancement that facilitated automated machine movements predicated upon the input of numerical data.

The inception of NC can be traced back to the late 1940s, when John Parsons and Frank Stulen at the Parsons Corporation were trailblazers in the application of numerical coordinates to govern the motion of milling machine tables, predominantly for the fabrication of intricate aerospace components. In a collaborative effort with the Massachusetts Institute of Technology (MIT), the U.S. Air Force financed a project aimed at developing a prototype NC machine tool, which was successfully showcased in 1952. The advent of NC signified a pivotal juncture in manufacturing, proffering substantial enhancements in accuracy, repeatability, and process efficiency in contrast to traditional manual methodologies.

The extensive implementation of NC technology throughout the 1950s, especially within the aerospace industry, underscored its capacity to optimize production processes and diminish nonproductive machine time. This transition was further stimulated by the creation of part programming languages, such as APT (Automatically Programmed Tooling) in 1958, which enabled users to articulate machining directives in a syntax reminiscent of the English language that was subsequently converted into machine-readable code. The confluence of NC with advancements in automation, digitalization, and precision engineering has propelled machining to the vanguard of industrial innovation. Presently, machining is integral to contemporary manufacturing, facilitating the creation of intricate, high-precision components across a

multitude of sectors. Its ongoing evolution underscores its paramount importance in fostering global scientific and technological advancement.

1.2. Literature Review: Challenges in Conventional Machining Processes

The progression of machining processes epitomizes humanity's relentless pursuit of innovation and adaptability in the manipulation of materials to meet the demands of contemporary industries. The evolution from conventional manual machining techniques, reliant on the dexterity and accuracy of human operatives, to contemporary computer numerical control (CNC) machining systems signifies a pivotal advancement in manufacturing technology. This evolution has been marked by considerable improvements in automation, precision, and efficiency, while simultaneously introducing enduring challenges such as the optimization of tool wear, the management of thermal impacts, and the navigation of the complexities inherent in machining advanced materials (Silva 2021; Goindi and Sarkar 2017).

In the domain of rotating workpieces, the evolution from conventional lathes to Computer Numerical Control (CNC) turning centers has fundamentally transformed the landscape of manufacturing. In the investigation conducted by Yallese *et al.* (2009), the performance of a cubic boron nitride (CBN) cutting tool during the hard turning process of 100Cr6-tempered steel was meticulously examined. The inquiry encompassed a series of protracted wear assessments aimed at delineating the impact of cutting speed on various manifestations of tool wear. A following series of experiments concentrated on the assessment of cutting forces, surface roughness, and thermal variations in both the generated chip and the machined surface. The results indicated that CBN tools demonstrate remarkable wear resistance notwithstanding the aggressive nature of 100Cr6 steel, which possesses a hardness of 60 HRC. Nevertheless, the investigation also underscored critical constraints: when cutting speeds surpassed 280 m/min, the machining setup exhibited instability, generating substantial thermal flashes and dynamic oscillations within just a short duration of operation.

In a similar study, Bhemuni *et al.* (2015) performed both experimental and numerical analyses to scrutinize the hard turning of AISI D3 and AISI H13 steels utilizing mixed ceramic cutting tools (CC6050) at feed rates ranging from 0.050 to 0.075 mm/revolution and cutting speeds spanning 145 to 165 m/min. The core focus of the research was on the stresses, forces, and thermal loads induced throughout the machining operation. The findings underscored that localized thermal flux and stress intensification along the tool's cutting edge were of particular

significance. These elements were demonstrated to detrimentally affect tool longevity, as the increased temperatures and localized stresses were capable of hastening wear and precipitating premature tool failure. Such challenges are especially pronounced when machining high-strength materials such as titanium and Inconel, which exhibit elevated rates of tool failure.

Initiatives aimed at alleviating wear, thermal degradation, and vibrations in machining processes through the application of advanced coatings and real-time vibration monitoring have exhibited considerable potential. However, the considerable costs associated with their implementation frequently present obstacles for smaller enterprises, thereby constraining broader acceptance. The gravity of these challenges is further accentuated by extensive research centered on wear mechanisms and tool efficacy in demanding machining conditions. Ezugwu and Wang (1997) explored the principal issues pertinent to the material removal processes of Ti-based alloys, with a specific emphasis on cutting tool wear and the mechanisms underlying failure of tool. Their investigation revealed that uncoated tungsten carbide (WC/Co) machining tools retained their supremacy across nearly all metal cutting processes involving Ti-based materials. This study elucidated the significance of material properties and tool design in mitigating wear and ensuring enhanced machining performance.

Haron, Ginting, and Goh (2001) conducted an evaluation of the operational efficacy of carbide tools with and without surface coatings used in machining hardened steel rods (23 HRC), utilizing a 35° diamond-shaped insert featuring basic channel patterns. The investigation incorporated TiCN, Al₂O₃, and TiN coatings, assessed under machining environments with and without coolant. The machining speed varied from 75 to 350 m/min, whereas the feed per revolution and depth of cut were held constant at 0.16 mm/rev and 1 mm, respectively. The results indicated that uncoated carbide tools exhibited functionality solely at machining speeds beneath 75 meter/minute, with a pronounced decline in tool longevity at increased velocities.

In contrast, coated carbide tools exhibited markedly enhanced performance, sustaining tool life for cutting speeds reaching up to 350 meter/minute—nearly 7 minutes in dry machining and approximately 15 minutes in wet conditions. Furthermore, the wet cutting approach was shown to confer advantages for carbide tools with coatings, as lubricants based on oil effectively facilitated the coatings by diminishing friction and thermal generation, thereby further augmenting tool life and machining efficacy. Additionally, Aslantas, Uzun, and Cicek scrutinized the tribological wear characteristics of both coated and uncoated ceramic Al₂O₃-TiCN mixed inserts during the cutting operation of heat-treated AISI 52100 steel (~63 HRC).

Single-point cutting analyses were undertaken with feed rates of 0.07, 0.11, and 0.14 mm/rev, utilizing cutting speeds ranging from 100 to 300 m/min, while keeping a consistent depth of cut at 0.5 mm. The findings elucidated that TiN coatings elevated wear resistance and tool life threefold. Moreover, the TiN coating substantially improved the toughness of the ceramic tool, markedly mitigating chipping damage. Regarding surface roughness, the TiN-coated cutting tools attained a cutting distance approximately eightfold longer in comparison to their uncoated counterparts, thereby highlighting the efficacy of coatings in prolonging tool life and enhancing machining quality.

The intricate challenges associated with milling advanced materials have persistently posed significant hurdles for researchers, particularly with respect to the optimization of tool performance, the influence of thermal effects, and the preservation of material integrity. Arunachalam, Mannan, and Spowage (2004) conducted a comprehensive examination of these complexities through an exhaustive investigation of facing operations performed on IN-718, a nickel-based superalloy characterized by a hardness of 36 HRC. By utilizing CBN and mixed ceramic cutting tools across a spectrum of cutting velocities ranging from 150 to 450 m/min, with feed rates set at 0.15 mm/rev and depths of cut varying between 0.05 and 0.5 mm, they elucidated significant challenges related to residual stresses and thermal effects. These stresses, exacerbated by the high-temperature machining conditions, detrimentally affect dimensional accuracy and surface integrity, thereby underscoring the intricate relationship between machining parameters and material behavior.

Sridhar *et al.* (2003) analyzed the milling characteristics of Ti-IMI 834, a titanium alloy distinguished by its remarkable strength and thermal endurance. Employing TiN-coated carbide tools, they executed experiments at a cutting speed of 11.56 m/min, with feed rates of 0.056 and 0.1 mm/tooth, and depths of cut of 0.25 and 2 mm. The analysis revealed a significant escalation in residual stress and thermal expansion, which presented substantial obstacles to precision. The phenomenon of thermal expansion, a direct result of excessive heat generation, engendered dimensional inaccuracies that proved challenging to regulate. Additionally, the heightened temperatures expedited tool wear, thereby underscoring the necessity for effective cooling strategies and tool optimization. The researchers advocated for the adoption of advanced coated tools as well as alternative cooling methodologies, such as minimum quantity lubrication (MQL) and cryogenic cooling, to alleviate these difficulties.

The efficacy of cryogenic cooling was further substantiated by Sadik and Isakson (2017), who investigated the face milling of Ti-6Al-4V, a titanium alloy extensively utilized in aerospace and biomedical sectors. Their experimental framework incorporated both uncoated and PVD-coated carbide inserts under conditions of cryogenic CO₂ cooling as well as traditional emulsion cooling. Encompassing cutting velocities from 60 to 100 m/min, feed rates of 0.1 to 0.2 mm/tooth, and a consistent depth of cut of 2 mm, the study illuminated that cryogenic cooling markedly augmented tool life, with PVD-coated tools achieving durability levels up to six times greater than those attained via conventional cooling methods. This enhancement was attributed to a reduction in thermal stress and friction, thereby affirming the effectiveness of cryogenic techniques within high-performance machining environments.

Sousa and Silva (2020) stressed the crucial significance of multilayer coatings in the advancement of tool functionality and machining standards. Their research demonstrated that multilayer coatings consistently surpassed the performance metrics of mono-layered and uncoated tools, providing superior wear resistance and thermal stability. These coatings not only extended the functional life of the tools but also elevated surface finish and machining productivity. Furthermore, the researchers underscored the critical importance of the deposition process, indicating that physical vapor deposition (PVD) and chemical vapor deposition (CVD) yielded coatings characterized by a diverse array of mechanical and thermal properties. The judicious selection of coating type and deposition technique emerged as a pivotal factor in addressing the challenges associated with high-speed, high-temperature machining applications.

Drilling, a critical process for the fabrication of precise cylindrical apertures, entails a distinct array of challenges. The occurrence of burr formation is a prevalent concern that frequently necessitates subsequent operations for remediation, as indicated by the findings of Aurich *et al.* (2009) and Ko and Lee (2001). Moreover, drill wander, particularly in the context of deep-hole drilling, exacerbates the difficulty of sustaining dimensional accuracy. To mitigate these challenges, Jin *et al.* (2020) asserted that a reduction in burr formation can be achieved through the careful consideration of tool geometry, material composition, coolant types, machining parameters, workpiece materials, strategic process planning, and tool path optimization, while underscoring the ongoing requirement for deburring to completely eliminate burrs.

Grinding, which is extensively acknowledged for its capacity to produce exceptional surface finishes, poses considerable challenges, particularly in terms of thermal degradation and

microstructural modifications, as elucidated by Malkin and Guo (2007, 2008). These challenges become notably evident when processing sophisticated materials like Ti-6Al-4V, wherein the production of excessive heat and concentrated thermal stress may jeopardize the structural integrity and operational efficacy of the material. To mitigate these difficulties, Mukhopadhyay and Kundu (2020), performed an empirical examination of the SQL-based drop-by-drop technique's performance while grinding Ti-6Al-4V using an alumina wheel. The study was performed utilizing both conventional coolant and dry modes under identical processing parameters. It was determined that the requirement for grinding force was significantly diminished when the SQL technique was employed, in contrast to both dry and flood cooling methods. Furthermore, the grinding ratio exhibited an enhancement of 1.5 times, while surface roughness demonstrated a reduction of approximately 58% compared to dry mode, and in relation to flood cooling, the grinding ratio improved by 1.3 times with a roughness reduction of around 23%. This enhancement was ascribed to the SQL technique's capacity to more effectively dissipate heat from the grinding zone, thereby mitigating thermal stress and improving the surface morphology of the material.

These investigations collectively underscore the persistent endeavors aimed at refining machining processes for sophisticated materials by tackling challenges such as thermal phenomena, residual stresses, and tool degradation through the implementation of innovative coatings, optimization of machining parameters, and advanced cooling methodologies. Among these difficulties, the thermal phenomena impacting tool degradation emerge as the most pivotal, as they markedly affect tool longevity, process reliability, and the caliber of the workpiece. To understand the complexities lucidly, a comprehensive summary of the major challenges associated with conventional machining processes along with associated effects are presented in Table 1.1.

Table 1.1. Challenges in Conventional Machining

Machining Process	Key Challenges	Associated Effects	References
Turning	<ul style="list-style-type: none"> • High cutting forces at elevated speeds and feeds. • Progressive tool wear (flank and crater). • Built-up edge (BUE) formation affecting surface finish. • Excessive heat generation causing thermal distortion and degraded surface integrity. 	<ul style="list-style-type: none"> • Dimensional inaccuracy and poor surface finish. • Reduced tool life. • Residual stresses and micro-structural alterations on the machined surface. 	Yallese et al., 2009; Bhemuni et al., 2015; Ezugwu and Wang, 1997.
Milling	<ul style="list-style-type: none"> • Excessive heat generation and residual stress formation. • Rapid tool wear due to high thermal and mechanical loads. • Thermal expansion and friction-induced instability. 	<ul style="list-style-type: none"> • Dimensional inaccuracies and loss of profile tolerance. • Surface integrity deterioration. • Premature tool failure and degraded surface finish. 	Arunachalam, Mannan, and Spowage, 2004; Sridhar et al., 2003; Sadik and Isakson, 2017; Sousa and Silva, 2020.
Drilling	<ul style="list-style-type: none"> • High thrust and torque due to chisel edge. • Tool wear and breakage under high temperature. • Chip clogging in flutes affecting heat dissipation. • Burr formation and poor hole quality. 	<ul style="list-style-type: none"> • Hole dimensional error and loss of straightness. • Thermal softening of drill tip. • Damaged surface integrity and burr formation. 	Aurich et al. 2009; Ko and Lee 2001; Jin et al., 2020.

<p>Grinding</p>	<ul style="list-style-type: none"> • High frictional heat generation in grinding zone. • Wheel loading and wear. • Thermal damage causing burns, residual stresses, and microcracks. • Difficulty in maintaining surface integrity. 	<ul style="list-style-type: none"> • Surface burns, microstructural changes, and tensile residual stress. • Reduced fatigue strength and poor finish. • Wheel glazing and loss of cutting efficiency. 	<p>Malkin and Guo 2007, 2008; Mukhopadhyay and Kundu, 2020.</p>
<p>Knurling</p>	<ul style="list-style-type: none"> • High forming pressure and friction at tool–work interface. • Tool wear and pattern distortion. • Surface tearing in ductile materials. • Localized heating and poor lubrication. 	<ul style="list-style-type: none"> • Non-uniform knurl pattern. • Surface damage and poor dimensional control. • Tool life reduction due to abrasive wear. 	<p>Zou et al., 2024.</p>
<p>Thread Cutting</p>	<ul style="list-style-type: none"> • High intermittent cutting forces • Notch wear & Chip crowding • High heat & Tool chipping / breakage 	<ul style="list-style-type: none"> • Thread form inaccuracies • Poor surface integrity • Increased friction • Premature tool failure. 	<p>Krawczyk et al., 2022; Akyildiz, 2013; Brandão et al., 2020; Zawada et al., 2021.</p>
<p>Boring</p>	<ul style="list-style-type: none"> • High cutting forces and tool deflection due to long overhang. • Chatter and vibration. • Tool wear and poor heat dissipation in deep boring. 	<ul style="list-style-type: none"> • Geometric errors and surface waviness. • Reduced tool life. • Instability during machining of hard alloys. 	<p>Xiao et al., 2014; Sastry et al., 2020.</p>

Addressing thermal degradation demands an organized methodology: initially, the assessment of the most compatible tool-workpiece material pairing that can resist thermal stress; thereafter, the adjustment of machining parameters such as cutting velocity and feed rate to manage heat production; and finally, the application of efficient cooling solutions, including cryogenic cooling or MQL, to improve thermal dissipation. From the extant literature, it is apparent that while the selection of suitable tool-workpiece material combinations and the optimization of machining parameters are critical, the selection of cooling strategies holds paramount importance. These methodologies not only alleviate thermal phenomena but also facilitate increased cutting velocities, enhanced tool efficacy, and improved productivity.

Chapter 2:

**Literature review and Objective of the
present work**

2. Introduction

Metal machining processes are associated with several critical challenges, including high heat generation, rapid tool wear, poor surface integrity, and elevated cutting forces. These issues can adversely impact productivity, dimensional accuracy, and the overall quality of machined components. To address these challenges and enhance machinability, the selection of an appropriate cooling and lubrication strategy is essential. Effective cooling not only aids in temperature control at the cutting zone but also contributes to reducing friction and improving tool life. In this regard, conventional cooling methods such as flood cooling, MQL, and cryogenic cooling have been extensively studied and implemented. The following literature review focuses on the application and development of these techniques in improving machining performance, as well as their associated limitations under various machining conditions.

2.1 Flood Cooling

Flood cooling, a conventional cooling technique in machining, involves the continuous application of large amount of cutting fluids to the cutting zone. This approach is primarily designed to reduce heat generation, minimize tool wear, and improve surface finish during machining processes.

2.1.1. Advantages of Flood Cooling

Flood cooling has been a cornerstone of conventional machining, with numerous advantages contributing to its widespread adoption. One of the most significant benefits is its ability to control thermal conditions effectively. The application of a continuous flow of cutting fluid serves as a medium for heat dissipation, which is particularly critical in high-speed machining. Studies, such as those conducted by Childs, Maekawa and Maulik (1988), have investigated the influence of coolant application on the regulation of tool temperatures during the turning processes of medium carbon steel utilizing high-speed steel tools. The experimental investigations were executed under cutting velocities varying between 33 and 61 m/min, alongside a feed rate established at 0.254 mm/rev, and a depth of cut fixed at 2.54 mm. The

study involved flooding the tool with a water-based coolant at rates of 0.25 to 2.5 liters per minute. Tool temperatures were determined experimentally using structural and micro hardness changes in the tool and theoretically using finite element analysis. Heat transfer coefficients between 10^3 and $5 \times 10^3 \frac{W}{m^2.K}$ were identified, showing that tool temperatures are highly sensitive within this range. At the maximum heat transfer coefficient of $5 \times 10^3 \frac{W}{m^2.K}$, the maximum tool rake face temperature was reduced by only 20 K, while the flank face saw reductions of 60–70 K. The efficacy of the cooling mechanisms was most pronounced in diminishing the temperatures within the tool holder, constraining any increase above 100°C to a proximal distance of 5 mm from the cutting edge. The findings underscore the paramount importance of factors such as coolant flow rate, directional application, and compositional formulation in realizing effective cooling strategies, thereby enhancing tool longevity and preserving precision in machining operations.

Kumar, Bhardwaj, and Joshi (2022) investigated the efficacy of conventional flood cooling techniques in mitigating drill temperatures during the process of titanium drilling. By employing coupled Computational Fluid Dynamics (CFD) and Finite Element Method (FEM) modeling, the investigation reveals that flood cooling leads to a reduction in drill temperatures between 25% and 38% relative to conditions lacking cooling. This approach facilitates substantial thermal regulation by promoting enhanced heat dissipation via a continuous flow of coolant surrounding the cutting edges. The numerical simulations exhibit a close correlation with empirical data, revealing a mere deviation of 4% to 12%, thereby highlighting the robustness of the conclusions drawn. These findings substantiate that flood cooling presents a pragmatic and effective strategy for the management of drill temperatures, rendering it beneficial for industrial machining operations.

Moreover, flood cooling significantly enhances tool performance and durability. By reducing friction at the tool-workpiece interface, it minimizes wear mechanisms like adhesion and abrasion. Research by Avila and Abrao (2001) explored the effects of cutting fluids on machining hardened AISI 4340 steel, emphasizing tool wear reduction as a key factor in improving machining quality and tool life. Continuous turning experiments revealed that emulsion-based fluids without mineral oil provided the best tool life and wear resistance, outperforming both dry cutting and synthetic fluids. The grease content in these emulsions enhanced lubrication, especially during heavy cutting, minimizing tool wear through reduced abrasion and diffusion.

Dry cutting achieved the lowest surface roughness during rough turning, while emulsion-based fluids excelled at higher cutting speeds, delivering consistent surface finishes. Fluid concentration significantly influenced outcomes; reducing emulsion concentration from 5% to 3% extended tool life at high speeds. However, fluids containing mineral oil resulted in poor performance, exacerbating wear and chipping. Cutting fluids also affected chip formation: emulsion-based fluids improved chip control compared to dry cutting and synthetic fluids. Despite this, catastrophic failures occurred at critical cutting speeds during rough turning. The findings underscore the importance of selecting cutting fluids tailored to specific machining conditions, balancing performance and environmental considerations to enhance tool life and machining efficiency.

Another advantage of flood cooling lies in its ability to improve surface finish. The lubricating properties of cutting fluids reduce the formation of built-up edges, which can negatively impact surface quality. For instance, Debnath, Reddy and Yi (2016) examined the influence of cutting parameters and fluid application levels on surface roughness and tool degradation during the CNC turning of mild steel utilizing TiCN+Al₂O₃+TiN-coated carbide tools. Employing a Taguchi orthogonal array methodology, the study demonstrates that feed rate (34.3%) and cutting fluid flow rate (33.1%) exert substantial effects on surface roughness; while cutting speed (43.1%) and depth of cut (35.8%) predominantly dictate tool wear. Importantly, cutting fluid plays a moderate role in both parameters, thereby enhancing surface quality and tool durability. Optimal outcomes were attained under conditions of elevated cutting speed (180 m/min), moderate depth of cut (1 mm), low feed rate (0.05 mm/rev), and low-flow high-velocity (LFHV) fluid application. This specific combination effectively minimized both surface roughness and tool wear, as corroborated by experimental validation. The results highlight the significant importance of regulated feed rate and LFHV fluid application in enhancing surface quality and extending tool longevity during conventional flood cooling practices.

Xavior and Adithan (2009) observed the effects of cutting fluids on surface integrity and tool degradation during the machining processes of AISI 304 stainless steel utilizing carbide tooling, with an emphasis on conventional flood cooling techniques. The study meticulously assesses various process parameters, including flank wear, surface roughness, cutting forces, and the temperature at the tool-chip interface. Coconut oil, recognized as an environmentally benign alternative exhibiting outstanding thermal and oxidative stability, was evaluated in

comparison to both emulsion and neat mineral cutting oils. The experimental results indicate that coconut oil significantly surpassed the other fluids in minimizing tool wear and enhancing surface finish attributable to its superior lubrication characteristics. An ANOVA analysis determined that feed rate emerged as the most pivotal factor influencing surface roughness, contributing 61.54%, whereas cutting speed exhibited the most pronounced effect on tool wear, contributing 46.49%. Furthermore, cutting fluids demonstrated a substantial influence on both surface roughness and tool wear metrics. Surface plots depicted the interactions among cutting speed, feed rate, depth of cut, and fluid type, thereby elucidating their synergistic effects. This extensive investigation underscores the viability of coconut oil as a sustainable cutting fluid, yielding superior surface quality and integrity in machining operations relative to traditional mineral oils.

Pimenov *et al.* (2021) conducted a comprehensive review of numerous studies that revealed the extensive adaptability of the flood cooling technique across diverse materials and machining operations. The traditional flood cooling method continues to serve as a crucial cooling and lubrication strategy within the domain of metal machining. This technique is extensively implemented in operations such as turning, milling, and drilling, wherein the uninterrupted flow of coolant proficiently dissipates thermal energy, mitigates tool wear, and enhances surface integrity. The conventional flood cooling approach necessitates the application of a considerable volume of coolant, approximately 600 L/h for single-point cutting tools in turning operations, typically executed at cutting speeds ranging from 45 to 135 m/min, feed rates varying between 0.10 and 0.32 mm/rev, and depths of cut spanning from 0.5 to 0.75 mm. Such parameters facilitate optimal thermal governance and lubrication in the cutting zone, thereby increasing overall machining productivity. Additionally, research indicates that flood cooling markedly enhances surface quality by alleviating adhesion wear and minimizing flank wear of the cutting tool. In the machining of titanium alloys such as Ti6Al4V, the utilization of flood cooling has been demonstrated to improve chip evacuation and prolong tool life by approximately 30% relative to dry cutting methods. Moreover, this technique facilitates lower cutting temperatures, which contributes to improved dimensional accuracy and decreased thermal deformation of workpieces. These benefits render flood cooling particularly efficacious for the machining of difficult-to-cut materials, where excessive heat generation could otherwise precipitate rapid degradation of cutting tools.

The systematic review by Binali *et al.* (2022) highlighted flood cooling as a pivotal strategy for conserving energy in machining processes, particularly for composites and super alloys. Flood cooling enhances heat dissipation at the cutting zone, reducing thermal damage to tools and workpieces, thereby minimizing energy-intensive corrective operations. Critical machining parameters such as feed rate, cutting speed, and depth of cut directly impact energy efficiency, with optimized settings ensuring lower cutting forces and improved material removal rates.

2.1.2 Drawbacks of Flood Cooling

Despite its many advantages, flood cooling presents several significant drawbacks that challenge its widespread adoption. Among the most pressing issues are the economic costs associated with the use of cutting fluids. According to Klocke and Eisenblätter (1997), coolant-related expenses can account for up to 17% of total machining costs, a figure that surpasses the cost of cutting tools themselves. This financial burden is further exacerbated by the need for regular fluid replacement and disposal, particularly when fluids become contaminated or degraded over time.

The environmental impact of flood cooling is another major concern. Cutting fluids, especially synthetic and semi-synthetic varieties, pose substantial risks to ecosystems when improperly disposed of. Research by Avila and Abrao (2001) highlighted critical challenges in managing waste streams generated by traditional flood cooling methods, emphasizing sustainable disposal practices. Traditional cutting fluids, particularly emulsions and synthetic variants, present significant disposal issues due to their environmental and economic impact. These fluids, while enhancing machining efficiency through lubrication, cooling, and chip removal, often contain mineral oils and additives that complicate waste treatment and increase disposal costs. The study identifies emulsion-based fluids without mineral oil as a more sustainable alternative, outperforming synthetic fluids and mineral oil-containing emulsions in tool life and surface finish. However, their usage still requires careful management due to their grease-based lubrication components. Dry cutting emerged as a promising alternative, reducing waste generation and achieving comparable or superior tool life and surface quality under specific conditions. Despite these advancements, challenges such as high cutting temperatures and wear mechanisms limit broader adoption of dry techniques, especially for critical tolerances. The

findings underscore the pressing need for eco-friendly cutting fluid formulations, improved waste handling systems, and further exploration of dry cutting technologies to minimize the ecological impact associated with machining processes.

Health and safety concerns are inherently linked to the application of cutting fluids. The comprehensive review conducted by Pimenov *et al.* (2024) encompassed a thorough analysis of health and safety considerations associated with flood cooling methodologies employed in the machining of super alloys, particularly those derived from titanium, nickel, and iron. Despite the fact that flood cooling is a widely adopted and efficacious cooling methodology, it poses various safety risks due to the potential inclusion of hazardous agents within the cooling fluids. The investigation highlighted that the employment of conventional flood cooling practices can lead to the release of harmful chemicals and fluids, which may aggravate the formation of hazardous occupational conditions. This methodology, although proficient in reducing friction and thermal accumulation, has been recognized as necessitating further examination to improve its effectiveness and mitigate its adverse health impacts. The study pointed out the threats associated with occupational exposure to these detrimental substances, which can culminate in dermal irritation, respiratory challenges, and persistent health ailments. Moreover, the environmental consequences of flood cooling, including waste generation and chemical runoff, further intensify its safety concerns.

Sharma, Dogra, and Suri (2009) conducted a comprehensive analysis of the obstacles encountered in machining processes, with a particular emphasis on thermal inefficiency and its consequential effects on tool degradation and overall machining efficacy. The investigation underscores the inadequacy of conventional cooling strategies employing cutting fluids in proficiently managing heat dissipation within the primary shear zone, particularly when processing materials characterized by low thermal conductivity, such as titanium alloys. The study delineates principal constraints associated with established cooling methodologies, including the substantial volume of cutting fluids necessitated and their insufficient regulation of temperature within the cutting zone. The generation of excessive heat during metal cutting exacerbates tool wear phenomena such as adhesion, diffusion, and abrasion, which culminates in a marked decline in tool longevity and machining productivity. Furthermore, the failure of traditional cooling mechanisms to effectively penetrate the tool-chip interface significantly constrains their ability to dissipate heat engendered by plastic deformation and friction.

Tool wear and surface quality are not always improved by flood cooling. Paradoxically, certain studies, like those by *Seah et al.* (1995), have rigorously investigated the efficacy of traditional flood cooling techniques employed in machining processes, with a specific focus on their repercussions on tool wear and longevity. The experimental procedure involved the turning of medium carbon steel utilizing uncoated tungsten carbide cutting tools on a Colchester lathe, with the application of a water-based coolant. In contradiction to established assumptions, the findings indicated that the application of coolant frequently intensified tool wear rather than alleviating it. Notably, the presence of coolant resulted in a 30% increase in flank wear at elevated cutting speeds when juxtaposed with dry cutting, thereby significantly diminishing the effective operational lifespan of the tool.

Furthermore, the coolant facilitated the development of deeper and narrower crater wear while relocating the wear zone closer to the tool tip, thereby compromising the integrity of the cutting edge. These results illuminate the limitations associated with flood cooling, including heightened wear and diminished tool performance, thereby contesting its widely held advantages in extending tool life. Visual representations, such as graphs depicting trends in flank wear, substantiate the analysis, highlighting the constraints of flood cooling within standard workshop environments. Similarly, surface roughness may increase due to the destabilizing effects of fluid turbulence at higher machining rates.

Dahmus and Gutowski (2004) conduct a thorough system-level environmental assessment of machining processes, elucidating the operational intricacies related to the maintenance of coolant systems. The research accentuates the necessity for consistent monitoring, effective filtration, and rigorous contamination management to optimize machining efficacy and promote environmental sustainability. Cutting fluids, predominantly comprised of water and oil, are integral in minimizing friction and facilitating the cooling of the machining operation. Nonetheless, the upkeep of these fluids encounters considerable challenges, as contamination from metallic debris, extraneous oil, and microbial proliferation can compromise fluid integrity, resulting in operational inefficiencies and heightened disposal expenses. The manuscript underscores that the formulation and stewardship of cutting fluids necessitate meticulous regulation in light of environmental legislations, especially regarding the incorporation of biocides and waste disposal methodologies. Furthermore, it discloses that coolant systems represent a substantial portion of the total energy utilization within machining activities, extending beyond the scope of material removal. The investigation demonstrates that

auxiliary systems, such as coolant filtration and circulation, can potentially consume more energy than the actual cutting operation, thereby necessitating advancements in fluid management protocols. By pinpointing inefficiencies within coolant system functionalities, the study advocates for the adoption of superior filtration methods, real-time monitoring technologies, and alternative cooling techniques like dry machining to alleviate environmental repercussions and enhance operational efficacy in manufacturing practices.

2.2 Minimum Quantity Lubrication Method

In response to the drawbacks of flood cooling, various alternative cooling methodologies have been investigated to optimize machining efficiency while concurrently mitigating environmental and economic repercussions. One such method is MQL, which employs a minimal amount of cutting fluid, frequently in the form of an oil mist or aerosol that is directly applied to the cutting zone. MQL markedly diminishes coolant usage, lessens waste, and guarantees effective cooling and lubrication, thereby contributing to prolonged tool durability and improved machining surface quality.

Cryogenic cooling, another viable alternative, entails the utilization of liquid nitrogen or carbon dioxide to achieve cooling of the cutting area at exceptionally low temperatures. This methodology has demonstrated improvements in the material removal rate and durability of tools, as it effectively prevents thermal deformation and curtails cutting forces. Nevertheless, its execution is intricate and financially burdensome, thereby restricting its broader implementation.

An innovative approach, referred to as drop-by-drop cooling, encompasses the regulated delivery of minute droplets of cutting fluid directly to the tool-chip interface. This technique facilitates precise cooling with minimal fluid consumption, offering localized cooling that mitigates thermal damage while simultaneously enhancing cutting efficiency. Drop-by-drop cooling yields a substantial decrease in fluid usage when juxtaposed with traditional flood cooling, rendering it a more sustainable alternative within machining operations.

The dawn of modern manufacturing has always been accompanied by the challenge of optimizing machining processes. Although traditional flood cooling methodologies have historically constituted the industry norm, their ecological ramifications, substantial

operational expenditures, and the associated concerns regarding worker health have prompted scholars to investigate sustainable alternatives. One such groundbreaking innovation that has garnered considerable attention is MQL, a methodology that aspires to transform machining by minimizing lubricant consumption while optimizing efficiency.

MQL functions by administering a finely atomized mist of lubricant directly to the cutting interface, thereby diminishing friction and enhancing thermal dissipation. Sharma *et al.* (2015) conducted a comprehensive analysis of MQL, highlighting its considerable influence on cutting forces, tool degradation, and surface integrity. Their investigation illuminated MQL's capacity to supplant traditional cooling techniques while preserving or augmenting machining efficiency. The research encompassed an evaluation of various MQL methodologies utilized across a spectrum of machining operations, including turning, milling, drilling, and grinding, thereby illustrating its efficacy across a wide array of materials. The results underscored that MQL produced results that were either comparable to or superior than those achieved through dry machining, particularly in terms of reducing cutting temperature (CT) and enhancing dimensional precision. The study also noted the scarcity of comparative analyses with flood machining, indicating a pressing need for additional inquiry in this field. Furthermore, MQL was determined to improve surface integrity by mitigating tool wear and damage. Subsequent research should prioritize the optimization of MQL parameters, the advancement of chip evacuation systems, and the investigation of sustainable lubrication alternatives such as vegetable oils to bolster its economic and environmental sustainability.

The quest for improved performance has led to the integration of nanofluids within MQL applications. Sidik *et al.* (2017) executed an extensive review of the utilization of nanofluids within machining processes, accentuating their significance in augmenting lubrication and thermal characteristics. The investigation revealed that the integration of nanoparticles into lubricants markedly enhances thermal conductivity and lubrication attributes, resulting in improved heat dissipation, diminished tool degradation, and superior surface quality. The authors assessed both traditional and advanced cooling methodologies, underscoring the benefits of nanofluids, particularly in the context of the MQL approach. Their results indicated that nanofluid-enhanced MQL significantly lowers the coefficient of friction and wear, thereby augmenting machining efficacy and tool dependability. Nonetheless, obstacles such as stability and elevated production expenses persist as impediments to extensive commercialization. The research additionally examined the prospects of hybrid nanofluids, proposing that further

empirical investigation is imperative to refine their application. In summary, the review highlights the promising implications of nanofluids in machining while advocating for ongoing innovations to optimize their advantages.

In a similar context, Roy *et al.* (2019) presented an exhaustive review regarding the function of diverse machining fluids in augmenting the efficacy of MQL technique applied in diverse machining operations, including turning, grinding, and milling processes. The investigation elucidates the ramifications of distinct machining fluids, encompassing vegetable oil, mineral oil, synthetic oil, and nanoparticle-infused fluids on the enhancement of machining parameters such as surface quality, machining temperature, tool wear, and the longevity of the cutting insert. Their review substantiates that nanoparticle-enhanced lubricants markedly diminish machining forces, curtail tool wear, and improve surface finish. The findings suggest that the application of nanofluids in MQL machining results in a pronounced decrease in machining temperature, thereby alleviating adhesion wear and extending tool lifespan. Experimental investigations referenced in the review indicate that the integration of nanographene into vegetable oil-based lubricants enhances surface integrity and tool durability. Moreover, MQL flow rate and feed rate were recognized as pivotal factors affecting surface roughness, with MQL flow rate contributing to a 73% enhancement in surface quality. Additionally, CuO nanofluid-based lubricants were discovered to improve surface integrity while decreasing energy partition during grinding operations, thus reinforcing the superiority of MQL over traditional flooded cooling methodologies.

MQL is not restricted to conventional work materials. difficult-to-machine alloys, such as titanium and nickel-based superalloys, present considerable machining difficulties attributable to their elevated strength and diminished thermal conductivity. Osman *et al.* (2019) conducted a comprehensive review on the implementation of MQL in the machining of Ti-6Al-4V, underscoring its advantages in terms of sustainability. Their investigation reveals that MQL significantly diminishes tool wear and extends tool longevity when juxtaposed with dry machining environments, thereby establishing it as a feasible alternative to traditional flood cooling techniques. Nevertheless, at elevated cutting velocities exceeding 150 m/min, lubrication difficulties emerge as a result of oil vaporization and a consequent reduction in viscosity. Internal MQL demonstrated superior performance relative to external MQL, achieving a reduction in workpiece temperature by as much as 50%. Crucial cutting parameters, including cutting speed, feed rate, and nozzle orientation, exert considerable influence on the

overall performance outcomes. Employing lower feed rates in conjunction with moderate cutting speeds serves to optimize the reduction of tool wear, whereas elevated feed rates and speeds contribute to accelerated tool deterioration.

The application of MQL utilizing vegetable oil effectively mitigates cutting temperatures in comparison to both wet and dry machining conditions. The integration of MQL with cryogenic techniques further augments tool longevity and diminishes cutting forces, particularly in the context of micro-milling operations. However, the implementation of significantly low air temperatures (oscillating between -30°C and -45°C) contributes to an increase in cutting forces caused by material hardening. Despite the aforementioned benefits, the efficacy of MQL under extreme operational conditions remains constrained. Additional investigative efforts are imperative to refine cutting parameters and lubrication methodologies to enhance performance outcomes. This review offers valuable insights into advancements in sustainable machining practices pertinent to both academic research and industrial applications.

In a similar investigation, Safie *et al.* (2022) conducted a comprehensive investigation into the viability of utilizing environmentally sustainable vegetable oils as substitutes for traditional metal cutting fluids (MCFs) within MQL contexts, specifically for the drilling of Inconel 718. The research centered on three non-edible oils—castor, neem, and rice bran—evaluating their efficacy in relation to tool longevity, tool degradation, surface integrity, dimensional precision, and chip thickness, employing a TiAlN-coated carbide drill for the analysis. Executed at cutting velocities of 10 and 20 m/min with a constant feed rate of 0.015 mm/rev, the study revealed that castor oil exhibited markedly superior machinability characteristics. At a cutting speed of 10 m/min, castor oil enhanced tool life by 50% in comparison to rice bran oil and achieved the minimum surface roughness ($1.455\ \mu\text{m}$) and chip thickness (0.220 mm) at 20 m/min. Additionally, it displayed the highest thermal conductivity, thereby mitigating tool wear and reducing cutting temperature. The results indicate that bio-based lubricants, especially castor oil, present a sustainable and efficacious alternative to synthetic oils, thereby promoting environmentally responsible machining practices.

There has been a significant amount of work in the area of MQL in grinding, however, grinding of titanium using MQL is a relatively unexplored area. Guo *et al.* (2012) conducted a thorough investigation into the implications of MQL on the grinding efficacy of Ti-6Al-4V utilizing a SiC abrasive wheel. Their research emphasized the examination of grinding force, surface roughness, and surface morphology under varying cooling methodologies: MQL, dry, and

flood cooling. The findings indicated that MQL offered the most advantageous lubrication, resulting in a substantial decrease in grinding force, specific energy, and force ratio in comparison to the dry and flood cooling methods. Furthermore, MQL produced the most optimal surface finish, characterized by the lowest surface roughness (Ra) across a spectrum of grinding depths. Conversely, dry and flood cooling induced surface damage manifesting as side flow, plastic deformation, and redeposition, which intensified as grinding depth escalated. In summation, the MQL system demonstrated enhanced surface integrity, as the lubricant infiltrated the contact zone more proficiently, thereby ameliorating lubrication and mitigating surface imperfections.

Biswojyothi *et al.* (2014) executed an extensive investigation concerning the grinding of the Ti-6Al-4V alloy utilizing the MQL methodology, emphasizing the manipulation of MQL parameters such as coolant concentration, coolant flow rate, and air pressure. The findings indicated that augmenting coolant concentration, coolant flow rate, and air pressure resulted in a reduction of grinding forces and surface roughness, thereby illustrating the efficacy of MQL in enhancing the grindability of Ti-6Al-4V. Among the various MQL conditions assessed, a moderate coolant flow rate coupled with elevated air pressure yielded the optimal grinding performance attributable to the boundary lubricated environment established at the interface between the wheel and workpiece. The research further elucidated the impact of coolant concentration and air pressure on chip morphology, disclosing the generation of substantial chip fragments at diminished coolant concentration and pressure, whereas elongated lamella-type chips were observed at augmented coolant concentrations and pressures. The results underscored that a high coolant concentration (4%) in conjunction with high air pressure provided the most favorable surface texture, devoid of burn marks or debris, thereby validating MQL as a viable technique for sustainable grinding practices.

Sadegi *et al.* (2009) conducted a comparative analysis of the grinding performance of Ti-6Al-4V utilizing minimal quantity lubrication (MQL) in conjunction with flood cooling methodologies. Their findings elucidated that MQL, employing synthetic oil-based coolants, afforded superior grinding performance relative to traditional flood cooling techniques. In particular, they ascertained that MQL markedly diminished both the perpendicular and tangential grinding forces. The application of synthetic oil exhibited enhanced performance compared to vegetable oil, manifesting in reduced tangential forces and improved surface quality. Furthermore, MQL utilizing synthetic oil yielded lower grinding forces and facilitated

enhanced surface morphology, all whilst preventing thermal damage to the surface. Nonetheless, it was noted that surface roughness was marginally elevated under MQL conditions as compared to conventional cooling, potentially attributable to the presence of sharper abrasives within the cutting zone, which produced pronounced shearing marks. Moreover, the research identified that the optimal parameters for MQL consisted of a lubricant flow rate of 60 ml/h and a delivery pressure of 4 bar. In summary, MQL grinding with synthetic oil exhibited the most favorable outcomes regarding the reduction of grinding forces and the enhancement of surface quality, whilst simultaneously being more ecologically sustainable.

Setti *et al.* (2015) conducted an investigation into the influence of nanofluids within the framework of the MQL system during the surface grinding process of Ti-6Al-4V alloys. The research encompassed the incorporation of Al₂O₃ and CuO nanoparticles at varying concentrations (0.05%, 0.1%, 0.5%, and 1%) suspended in water, which served as the base fluid. The findings revealed a considerable reduction in the coefficient of friction when utilizing Al₂O₃ nanofluid, with the most pronounced decrease occurring at elevated nanoparticle concentrations. This diminishment in friction resulted in a reduction of tangential grinding forces and a decrease in the temperature of the grinding zone. Furthermore, the application of nanofluid promoted efficient chip removal from the grinding zone, particularly with Al₂O₃ nanofluid, which significantly enhanced cooling efficiency and mitigated thermal damage. The investigation also noted an enhancement in surface integrity and morphology, characterized by diminished wear on the grinding wheel and the production of finer chips. Al₂O₃ nanofluid exhibited particular efficacy in the formation of a tribofilm, culminating in extended tool life and improved grindability of Ti-6Al-4V. These observations underscore the promising potential of nanofluid-enhanced MQL systems for precision grinding applications.

Hegab *et al.* (2019) conducted a thorough investigation into the utilization of multi-walled carbon nanotube (MWCNT)-augmented nano-cutting fluids within MQL systems, aimed at enhancing the machinability of Ti-6Al-4V alloys. Titanium alloys find extensive application in high-performance settings due to their outstanding mechanical attributes; however, their fundamental low thermal conductivity and increased chemical reactivity lead to inadequate machinability and hastened tool deterioration. To mitigate these issues, the research meticulously evaluated the influence of MWCNTs on surface integrity, chip formation, and tool wear across a spectrum of cutting parameters. The findings indicated that the presence of 2 wt% MWCNTs contributed to a 50% lowering of surface roughness, whereas elevating the

content to 4 wt% MWCNTs resulted in a 38% improvement. The enhanced thermal dissipation and lubrication facilitated by the nanotube-infused fluid contributed to diminished cutting forces, prolonged tool lifespan, and an improved chip morphology. These findings highlight the promising capabilities of nano-enhanced MQL fluids in optimizing machining efficacy, although further investigations are warranted to elucidate the tribological and heat transfer mechanisms involved.

Chaudhari, Khedkar, and Borkar (2011) utilized the Taguchi optimization methodology to refine MQL parameters in turning operations, thereby maximizing the industrial advantages of the technique. Their investigation established a singular characteristic response optimization framework to meticulously adjust essential process parameters, which encompass cutting speed, feed rate, depth of cut, and the nose radius of a single-point cutting instrument. By employing Taguchi's L9 orthogonal array for the design of experiments, they ascertained that an elevated cutting speed and depth of cut, in conjunction with a reduced feed rate, optimized both the material removal rate and surface roughness. The research underscored the economic feasibility of MQL for the machining sector by diminishing lubrication consumption, consequently reducing machining expenses and alleviating environmental and health issues. Furthermore, the study confirmed that MQL outperformed conventional flood lubrication with respect to cutting performance, highlighting the critical role of process parameters in controlling tool wear and enhancing surface finish during turning operations on mild steel.

Recent investigations have also underscored the beneficial effects of SQL/MQL strategies in the machining of difficult-to-machine (DTM) materials. However, under the extreme pressure and thermal conditions at the chip-tool interface near the primary cutting edge, these advanced lubrication techniques often fall short in effectively reaching the cutting zone. In a study examining various coolant delivery strategies to improve the machinability of Ti-6Al-4V, Das *et al.* (2022) reported that methods ensuring deeper and more efficient penetration into the tool-workpiece interface exhibit superior performance compared to conventional approaches.

In addition to continuous mode, MQL technique has also been applied in drop-by-drop (DBD) mode to grind titanium alloys. Mahata *et al.* (2014) conducted experimental investigation into the grindability characteristics of low alloy steel utilizing the DBD cooling technique. Their research juxtaposed dry and wet grinding methodologies, demonstrating that elevated coolant concentrations (1:20) markedly diminished both tangential (F_t) and normal (F_n) forces, attributable to enhanced lubrication properties. Surface roughness parameters (R_a , R_t , R_z)

exhibited reductions during wet grinding processes, thereby facilitating improved cooling and lubrication effects. Optimal chip formation was noted under conditions of high fluid concentration. The results underscore the critical significance of strategically optimized coolant application in diminishing force requirements and enhancing surface quality, which in turn contributes to the overall grinding efficiency.

Mahata *et al.* (2018) investigated the efficacy of a drop-by-drop cooling technique utilizing soap water for the grinding of Inconel 718, a particularly challenging nickel-based superalloy. This technique was evaluated in comparison to both dry grinding and the microjet delivery of soap water. The drop-by-drop application demonstrated a significant reduction in grinding forces relative to dry grinding, although it did not achieve the effectiveness observed with the microjet method. The surface finish exhibited marked improvement with the incorporation of soap water, accompanied by a slight decrease in surface roughness (R_a) when juxtaposed with dry grinding. The chip formation process under the drop-by-drop cooling methodology predominantly involved shearing and flowing types, analogous to the microjet application, albeit with marginally reduced material removal efficiency. The drop-by-drop cooling technique provided a moderate enhancement in grinding ratio and energy consumption, yet it remained less effective than the microjet method. In summary, although the drop-by-drop approach exhibited promise, the microjet technique proved to be superior in minimizing grinding forces, enhancing surface finish, and optimizing grinding performance.

Kundu *et al.* (2018) investigated the utilization of soap water as a potential alternative grinding fluid for titanium Grade 1, a material characterized by its challenging grindability and employed in aerospace, automotive, and biomedical sectors. The research delineates a comparative analysis of two distinct delivery mechanisms: drop-by-drop and high-velocity jet. The findings indicate that although the drop-by-drop approach attains a considerable grinding ratio (G-ratio), it concurrently leads to increased forces and results in compromised surface quality, characterized by surface burn. Conversely, the application of jet-assisted soap water mitigates tangential forces, enhances surface quality, reduces surface roughness, and facilitates the formation of shear-type chips, thereby suggesting superior grindability. The research concludes that both methodologies present effective, economically viable, and environmentally sustainable alternatives for the grinding of titanium-based alloys utilizing alumina wheels. Notably, the jet application exhibits more advantageous outcomes regarding force diminution and surface finish. This study underscores the promising potential of soap water as a feasible

substitute for conventional coolants in grinding processes. Another advantage of this method is that it works under gravity that does not demand external power. Favourable results are obtained using this MQL technique.

As various industrial sectors increasingly strive for sustainable and economically feasible manufacturing methodologies, MQL emerges as a pivotal advancement. Its ability to significantly reduce coolant consumption, enhance tool durability, and improve machining efficiency establishes it as a fundamental approach within modern manufacturing practices. With ongoing advancements in nano-additives, bio-lubricants, and hybrid cooling strategies, the potential advancements in MQL are positioned to revolutionize the domain of machining technology, thereby enabling a transition towards a more sustainable and effective industrial framework.

2.3 Cryogenic Cooling Method

Cryogenic cooling has surfaced as a highly promising methodology in the domain of metal machining, attributed to its capability to prolong tool longevity, enhance surface integrity, and alleviate thermal stresses. This technique encompasses the utilization of cryogenic fluids, such as liquid nitrogen (LN₂) or carbon dioxide (CO₂), directed towards the cutting zone during the machining operations. Although this approach presents considerable advantages over alternative cooling strategies, such as MQL, cryogenic cooling is not devoid of its limitations, which include elevated operational expenditures and the complexity of the requisite equipment. Moreover, the reduction of tool wear highlights another area where cryogenic cooling surpasses MQL.

2.3.1. Advantages of Cryogenic Cooling Method

Dhar *et al.* (2002) conducted an investigation into the efficacy of cryogenic cooling employing liquid nitrogen (LN₂) jets within machining operations, with a particular focus on the turning of plain carbon steel (C-40) across a spectrum of cutting velocities and feeds. Their research underscored the inadequacies of conventional cutting fluids, which frequently do not function at peak efficiency under elevated cutting velocities and feeds, while also contributing to

ecological degradation. Conversely, it was determined that cryogenic cooling markedly diminishes cutting temperatures, thereby not only prolonging tool lifespan but also improving the quality of the final product. The investigators illustrated that LN2 jet cooling surpasses traditional oil-based microfilms, especially in alleviating abrasive and adhesive wear during the machining of resilient materials such as stainless steel and titanium alloys. The experimental and computational findings of the study revealed advantageous chip formation, diminished cutting forces, and enhanced chip-tool interaction in cryogenic environments. The application of cryogenic cooling not only augments machinability but also offers an environmentally sustainable alternative, thereby affirming its viability in industrial contexts.

Binali *et al.* investigated the energy advantages associated with advanced lubrication and cooling methodologies, encompassing cryogenic fluids and MQL, within the context of machining processes. Their results reveal a potential energy conservation of up to 27% through the application of cryogenic cooling, thereby underscoring its efficacy in mitigating friction and thermal generation. In the case of superalloys, the implementation of effective flood cooling not only prolongs tool longevity but also diminishes specific cutting energy (SCE) by facilitating more efficient chip formation and achieving reduced cutting temperatures. These technological advancements play a crucial role in promoting sustainable machining practices by enhancing operational efficiency and minimizing carbon emissions, thereby emphasizing the critical importance of optimized cooling strategies in advancing efforts toward machining sustainability.

2.3.2. Drawbacks of Cryogenic Cooling

Despite its many advantages, cryogenic cooling is not without its challenges. One of the most prominent drawbacks is the high cost associated with the implementation and operation of cryogenic systems. The specialized equipment required for the storage and delivery of cryogenic fluids represents a significant initial investment, making the technology less accessible for small-scale or cost-sensitive operations.

Hong and Ding (2001) conducted an investigation into the efficacy of cryogenic machining for cooling purposes during the machining of Ti-6Al-4V, a difficult to machine material, frequently utilized in aerospace applications. Their research entailed a comparative analysis of

diverse cooling methodologies, encompassing conventional emulsion cooling, dry cutting, and cryogenic techniques, with a particular emphasis on the utilization of liquid nitrogen (LN2) as a cooling agent. They proposed a novel LN2 dispensing approach, which was applied locally to the cutting edge through micro jets aimed at the flank, rake, or a combination thereof, demonstrating marked superiority in mitigating cutting temperatures in contrast to emulsion cooling. The study employed finite element modeling alongside experimental validation via thermocouples, revealing that cryogenic machining presented a more environmentally sustainable and efficient alternative to conventional cooling strategies. Nonetheless, they underscored the persistent financial burden associated with the procurement of liquid nitrogen or carbon dioxide as a significant obstacle, which could potentially escalate operational expenditures.

The investigation conducted by Lu, Kudaravalli, and Georgiou (2018) examined cryogenic machining as a viable sustainable alternative to traditional flood cooling methods, with a particular emphasis on economic, environmental, and societal ramifications. While the authors underscore the prospective benefits of cryogenic cooling, which encompass enhanced cutting performance and diminished environmental consequences, numerous limitations are also articulated. A primary obstacle is the intricacy and financial implications associated with the implementation of an optimized cryogenic cooling apparatus. The liquid nitrogen delivery mechanism and cutting tool design, despite their efficiency, necessitate considerable investment in specialized apparatus and meticulous oversight of flow and temperature regulation. Moreover, the assurance of a stable, single-phase liquid nitrogen stream and the attainment of effective heat dissipation within the cutting zone pose significant engineering challenges. The manuscript further highlighted that notwithstanding its sustainability advantages, cryogenic machining may not universally be economically viable or practical for all machining contexts.

In the quest for enhanced cooling efficacy, scholars have investigated hybrid methodologies that integrate MQL with alternative cooling strategies. Senevirathne and Fernando (2012) conducted a comprehensive review of hybrid cooling methodologies, with a particular emphasis on the ramifications of integrating cryogenic cooling with MQL within machining operations involving materials that pose significant challenges to processing. Their investigation sought to delineate optimal cooling paradigms pertinent to the die and mould fabrication industry. The research elucidated the merits of employing Liquid Nitrogen Cooling

(LNC) alongside Chilled Air and Minimum Quantity Lubrication (CAMQL) as viable alternatives to traditional emulsion cooling, underscoring the prospective benefits associated with hybrid strategies. They noted that hybrid cooling substantially improves tool longevity, dimensional precision, and diminishes cutting forces and friction, thereby positioning it as a more ecologically sustainable option. Nonetheless, they identified a lacuna in research regarding its applicability to materials commonly utilized in the industry and advocated for additional inquiries into material-specific effects, economic viability, and comparative analyses of hybrid cooling techniques.

He *et al.* (2024) conduct a comprehensive analysis of hybrid cooling methodologies within MQL systems, accentuating their potential for fostering sustainable and efficient machining practices. Hybrid cooling, which amalgamates various cooling and lubrication approaches, significantly enhances thermal dissipation and tool durability whilst mitigating environmental repercussions. The investigation elucidates the integration of supercritical CO₂ (Sc-CO₂) with oil-on-water (OoW) technology, which collaboratively augments cooling efficacy by capitalizing on CO₂'s rapid thermal absorption and the lubricative attributes of oil. The researchers further articulate the benefits and constraints associated with vegetable oil-based cutting fluids, particularly within hybrid systems where their thermal conductivity and anti-wear properties can be ameliorated through the incorporation of nanoparticle additives. Furthermore, advancements in oil mist regulation and the optimization of intelligent MQL parameters are examined, promoting the adoption of AI-driven adaptive cooling mechanisms. The research emphasizes the necessity for further investigation into hybrid cooling methodologies to enhance energy efficiency and machining accuracy while concurrently ensuring environmental sustainability.

2.4. Microchannel Heat Sink

The effective cooling of systems necessitating proficient thermal regulation has emerged as a fundamental aspect of contemporary technological progress. Microchannel heat sinks, characterized by their superior cooling rates and remarkable surface area-to-volume ratios, present a viable solution for thermal dissipation across a range of applications. These systems are particularly essential in domains such as electronics, aerospace, and manufacturing, where effective thermal management is imperative for operational efficiency and longevity. By

reducing the volume of coolant required while preserving cooling efficacy, microchannels offer a sustainable and effective alternative to conventional cooling approaches.

Microchannels function based on the mechanism of convective heat transfer, wherein coolant circulates through meticulously engineered channels to draw heat away from elevated temperature surfaces. The distinct geometric configurations and material characteristics of microchannels substantially affect their thermal efficiency. Empirical studies have consistently validated the capacity of microchannels to attain substantial heat flux dissipation with minimal coolant utilization.

Nilson *et al.* (2006) performed foundational research on evaporative cooling dynamics within open rectangular microchannels, revealing that the cooling efficiency is mainly contingent upon the maximum sustainable heat flux, which does not vary with respect to channel dimensions, flow characteristics, and fluid properties. Employing both analytical and numerical methodologies, the research scrutinized steady-state evaporating flows and delineated two primary flow regions: an entry region characterized by the adherence of the meniscus to the upper corners and a corner-flow region where the meniscus retreats to the lower corners. A notable transitional alteration in fluid depth is observed between these distinct regions, exerting a significant influence on flow dynamics. In scenarios where gravitational forces facilitate flow, an intermediary region manifests, in which the meniscus gradually descends along the lateral walls prior to establishing itself at the channel base. Furthermore, the investigators developed precise analytical solutions to corroborate numerical models, thereby ensuring the reliability of the analysis concerning transitional effects and singularities associated with fluid pressure and velocity. A comprehensive analytical model, amalgamating these flow regions, adeptly forecasted maximum sustainable heat fluxes with a high degree of fidelity to numerical outcomes.

The investigation revealed that augmenting the channel's aspect ratio from 0.5 to 5 markedly elevates maximum sustainable heat flux (Q_{max}^*); however, the configuration of the inlet meniscus is of paramount importance, wherein a flat meniscus facilitates the optimal axial capillary flow. Nevertheless, an increase in channel depth prolongs the conduction pathway, which may result in excessive temperature differentials and subsequent boiling phenomena. These discoveries underscore the imperative for a holistic model that encompasses all pertinent physical processes to optimize the design of evaporative cooling systems. This scalability

accentuates the adaptability of microchannels for sophisticated cooling applications, illustrating their potential for extensive implementation in thermal management frameworks.

Kabov *et al.* (2011) extended these findings by undertaking experimental studies focused on the dynamic behavior of shear-driven liquid films within micro gap channels. Their research was centered on the effects of locally heated shear-driven liquid films in a 2 mm flat mini-channel, utilizing water and FC-72 as the working fluids. The findings of the research underscored the emergence of intricate two-dimensional (2D) and three-dimensional (3D) wave formations within the liquid films, which significantly augmented the critical heat flux (CHF) by a factor of ten in comparison to falling liquid films. This characteristic renders shear-driven films exceptionally proficient for applications necessitating expedited heat dissipation, including advanced semiconductor cooling in both terrestrial and extraterrestrial environments. Additionally, the investigation provided a comprehensive mapping of the flow sub-regimes, illustrating that water films can attain a smooth state under certain liquid/gas flow rates, whereas FC-72 films consistently manifest wave-like and cellular structures attributable to vigorous evaporation. A pivotal observation was that shear-driven liquid films exhibit a lower propensity for rupture compared to gravity-driven films, thereby mitigating the occurrence of dry patches that compromise heat transfer efficacy.

The identified wave patterns, shaped by elements such as thermo-capillarity, Kelvin-Helmholtz instabilities, and contact-line forces, denote the necessity for further systematic inquiries to thoroughly elucidate the interactions among evaporation dynamics, gas flow influences, and film stability within micro-gap cooling systems. Building on these experimental insights, Wang *et al.* (2018) explored the enhancement of heat transfer efficiency in microchannel heat sinks (MCHS) utilizing slant rectangular ribs (SRRs). Through computational simulations, the researchers assessed single- and double-row configurations of SRRs within a Reynolds number spectrum of 62.5–625. The research concluded that double-row ribbed microchannels (DRC) exhibit a marked superiority over single-row ribbed channels (SRC) owing to the stable vortex pairs generated, which enhance fluid mixing and thermal dissipation. Conversely, SRC produces a stable single-vortex configuration, resulting in less-than-optimal enhancement of heat transfer. The investigation underscores three pivotal mechanisms for the augmentation of heat transfer in MCHS: disruption of the thermal boundary layer, expansion of the heat transfer area, and the induction of chaotic advection through vortex generation.

The inclusion of SRRs disrupts the boundary layer and fosters fluid circulation, thereby improving heat exchange efficiency. Significantly, the efficacy of DRC is enhanced as the stable vortex pairs proficiently transport fluids, leading to more effective thermal management. The researchers fine-tuned several geometric parameters of SRRs, including attack angle, height, length, and pitch, to optimize the Nusselt number for uniform pump power. This study enhances the design of more effective microchannel systems by providing a thorough comprehension of the flow dynamics and thermal transfer mechanisms connected with SRRs.

Building upon the foundational tenets of microchannel heat sinks (MCHS) and their efficacy in thermal dissipation, subsequent investigations have examined variations in microchannel architectures to enhance performance for particular applications. While the preliminary discourse underscores the significance of microchannel morphology, convective heat transfer phenomena, and vortex-induced augmentations in thermal dissipation, later inquiries broaden this knowledge base by juxtaposing open and closed microchannel configurations. These examinations accentuate the compromises inherent in evaporative cooling, pressure losses, contamination vulnerabilities, and long-term dependability, thereby offering a comprehensive perspective on advancements in MCHS technology. The incorporation of computational fluid dynamics (CFD) modeling, material advancements, and hybrid microchannel frameworks further enhances the versatility of these systems, effectively linking core heat transfer principles with practical engineering solutions for high-performance cooling applications.

Microchannel heat sinks (MCHS) have emerged as pivotal components in the realm of thermal management, particularly pertinent to high-performance electronic systems that necessitate effective heat dissipation within constrained volumetric environments. These systems are typically classified into two categories: open and closed microchannels, each presenting unique advantages and inherent challenges. Open microchannel heat sinks are marked by their exposed channels, which encourage direct interaction between the coolant and the surrounding milieu. This configuration can augment evaporative cooling processes, rendering it advantageous for applications where such thermal mechanisms are advantageous. Nevertheless, open microchannels are vulnerable to complications such as contamination and heightened evaporation losses.

In response to these challenges, researchers have undertaken various investigations into design modifications and enhancements in materials. Bhandari *et al.* (2024) performed an extensive review into the design adjustments related to microchannel heat sinks (MCHS), emphasizing

the critical role these changes play in enhancing thermohydraulic efficiency, particularly in electronic cooling scenarios. The investigation centered on a myriad of strategies aimed at optimizing heat dissipation through MCHS, which have garnered considerable attention owing to their superior surface area-to-volume ratio. The review elucidates both active and passive methodologies employed to augment heat transfer, acknowledging that these techniques frequently entail trade-offs, including heightened pressure drop and flow complications.

A salient component of the study is the distinction made between open and closed microchannels. Open microchannels provide superior heat dissipation capabilities yet expose the coolant to potential environmental hazards, while closed systems alleviate contamination and evaporation concerns by maintaining the coolant in a sealed environment. This configuration proves particularly advantageous for electronic cooling, where the preservation of a stable and controlled environment is paramount for the longevity and performance of devices. The manuscript explores various design modifications, including channel cross-section, waviness, vortex generators, and bifurcation, while assessing their efficacy in addressing challenges such as flow maldistribution, temperature non-uniformity, and the formation of hot spots. The review further emphasizes the necessity for additional experimental validation, as the majority of investigations in this field are predominantly numerical. Researchers concluded that the pursuit of innovative design solutions remains crucial for the advancement of MCHS technology.

Studies by Mitra and Ghosh (2021) provided an analytical framework for evaluating convective heat transfer in microchannel heat sinks, specifically incorporating solid axial conduction. The study decomposed the system into two coupled boundary value problems to separately analyze heat transfer via the sidewalls/fins and the base wall/substrate. This analytical approach yielded closed-form solutions for the net temperature rise of both the wall and fluid, validated against experimental data and a three-dimensional conjugate computational model, demonstrating strong agreement. A key finding was that axial conduction introduces nonlinearities in the temperature profiles of both the solid and fluid, influencing heat distribution along the channel length.

Notably, uniform heat flux applied at the substrate does not translate into uniform heat transfer to the fluid, as axial conduction causes heat to be predominantly absorbed near the channel entry. The study's results are crucial for designing closed microchannel heat sinks, where maintaining consistent hydraulic performance and reliability outweighs the benefits of higher

heat transfer rates associated with open microchannels. Their model underscores the trade-off between thermal efficiency and system stability, offering valuable insights for optimizing closed-system microchannel heat sinks. The validated approach enhances predictive capabilities in thermal management applications, reinforcing the importance of axial conduction effects in microchannel design.

Gilmore *et al.* (2020) introduced an open manifold microchannel heat sink to enhance high heat flux electronic cooling by significantly reducing pressure drop while maintaining low thermal resistance and a thin planar profile suitable for microfabrication. By eliminating ineffective nozzle constrictions and removing microchannel walls beneath slot nozzles, the open geometry achieved 45–75% pressure drop reduction in the microchannel model and 25% in the manifold model, with negligible changes in thermal resistance at certain flow rates. Wider channels demonstrated up to 77% pressure drop reduction, though with a slight increase in thermal resistance due to reduced jet velocity. Flow maldistribution was identified as a key challenge, affecting thermal resistance at varying flow rates, and was suggested to be mitigated through manifold optimization.

Chamfering microchannel tips showed similar, albeit lesser, benefits. The study underscores the potential of open microchannel heat sinks, highlighting the importance of flow uniformity for maximizing thermal performance. Furthermore, hybrid microchannel systems integrating open and closed designs are emerging as a promising solution to leverage the strengths of both configurations. Future research should focus on experimental validation, optimization strategies, and broader parametric studies to advance practical applications in electronics cooling. Hong and Cheng (2009) conducted a thorough three-dimensional numerical investigation and optimization of offset strip-fin microchannel heat sinks (MCHS) intended for microelectronic cooling, utilizing computational fluid dynamics (CFD) modeling to enhance operational efficiency.

The study employed a mathematical framework that encompassed the Navier-Stokes equations and principles of energy conservation, while concurrently considering conjugate heat transfer between the heat sink substrate and the liquid coolant. The numerical analyses demonstrated that the periodic alteration in flow direction and the disruption of the boundary layer considerably augmented convective heat transfer by facilitating improved fluid mixing. The authors analyzed the impact of geometric parameters, including the fin interval-to-length ratio (K) and the number of fins (M), on the thermal efficiency of the heat sink. The results suggested

the existence of an optimal K and M that effectively minimizes pressure loss or pumping power while adhering to the constraint of maximum wall temperature, with K=1 identified as the most favorable value. This integrative strategy for design optimization yields significant insights into enhancing MCHS efficiency for applications in microelectronics.

Sadique and Murtaza (2022) conducted a comprehensive review on heat transfer augmentation in microchannel heat sinks (MCHS), emphasizing secondary flows and computational fluid dynamics (CFD) optimization of microchannel geometries. The investigation underscores the increasing necessity for sophisticated heat dissipation methodologies attributed to the miniaturization of electronic devices and the concomitant rise in heat flux. Scholars have investigated an array of cooling strategies, concentrating on passive techniques such as geometric alterations, which facilitate enhanced heat transfer by inducing disruptions in the boundary layer and generating secondary flows. The review accentuates the importance of fractal-shaped MCHS in minimizing temperature non-uniformity while maintaining a negligible pressure drop. CFD is integral to the optimization of these configurations by forecasting thermal performance and the dynamics of fluid flow. Furthermore, innovations in materials have broadened the functional capabilities of MCHS, thereby advancing thermal management practices. This study delivers a meticulous evaluation of contemporary developments, providing valuable insights into the advantages and constraints of novel high heat flux cooling systems.

Rehman *et al.* (2020) executed a comprehensive thermodynamic evaluation of microchannel heat sinks (MCHSs) featuring innovative sidewall ribs (SWRs), with the objective of optimizing cooling efficacy while concurrently addressing hydrodynamic efficiency. The research utilized advanced numerical simulations to explore the heat transfer and fluid dynamic characteristics in MCHSs that incorporated various SWR geometries—ellipse, trapezoid, hydrofoil, and rectangle. Through an analytical approach that considered metrics such as the Nusselt number ratio, friction factor ratio, thermal enhancement factor, transport efficiency, and entropy generation rates across Reynolds numbers ranging from 100 to 1000, the investigators established that the hydrofoil SWR configuration surpasses the alternatives, achieving the most substantial enhancement in heat transfer coefficient (26.3%) while concurrently maintaining comparatively low rates of entropy generation. Nevertheless, this design engenders a 66% elevation in pressure drop when juxtaposed with a conventional straight MCHS, thereby necessitating increased pumping capacity. In spite of the inherent

trade-offs, the hydrofoil SWR configuration emerged as the most thermodynamically efficient option, successfully balancing augmented thermal performance with tolerable pressure drop metrics.

Alihosseini *et al.* (2020) executed an exhaustive review concerning the influence of micro heat sink (MCHS) geometric configurations on thermo-hydraulic efficacy, accentuating the importance of surface alterations in optimizing thermal transfer. As electronic apparatuses continue to undergo significant miniaturization, the implementation of effective cooling mechanisms, such as MCHS, is essential for the proficient dissipation of thermal energy. The investigation organized design factors into three principal dimensions: flow passage configurations, cross-sectional geometries, and inlet/outlet manifold layouts. Through the assessment of various flow patterns—including periodic, spiral, pin-fin, and oblique channels—the scholars illustrated that alterations in channel trajectories could augment performance via the generation of secondary flows and the disruption of boundary layers.

The cross-sectional evaluation indicated that rectangular microchannels exhibited superior performance regarding pressure reduction and thermal transfer, whereas circular geometries demonstrated enhanced efficacy in micro pin-fin applications. Furthermore, the research underscored the importance of manifold architecture in mitigating maldistribution, with triangular headers and vertical inlets providing optimal flow homogeneity. A performance evaluation criterion (PEC) was computed to delineate optimal geometries, thereby facilitating enhanced design determinations. The results emphasized the critical equilibrium between efficiency, longevity, and dependability in the development of MCHS, reinforcing the imperative for accurate geometric configurations to elevate cooling performance in electronic settings.

Ozguç *et al.* (2021) explored topology optimization of microchannel heat sinks using a homogenization approach to enhance durability and performance. Unlike traditional penalization methods that enforce strictly solid or open regions, their formulation represents partial densities as porous microstructures, facilitating the design of sub-grid features manufacturable via additive techniques. The study focused on a liquid-cooled microchannel heat sink subjected to a hotspot over a uniform heat input, modeling pin fins as porous media with volume-averaged properties. The optimization revealed fractal-like pathways that direct liquid through low-resistance manifolds and force it across tightly packed pin fins for effective heat dissipation. Open microchannels demonstrated superior heat transfer but required

environmental interaction, while closed microchannels ensured robustness and contamination resistance. The optimized designs significantly outperformed conventional straight microchannel heat sinks, achieving lower thermal resistance at set pressure drops. The findings underscore the efficacy of homogenization in achieving resolution-independent performance at reduced computational cost. Emerging research continues to push the boundaries of what is achievable in microchannel heat sink technologies, paving the way for innovative solutions to modern thermal management challenges.

2.5. Integration of Microchannel heat sink in Machining

The integration of microchannels in machining tools draws inspiration from advancements in microchannel heat sink (MCHS) technology, where efficient thermal management has been extensively explored. Just as MCHS designs optimize heat dissipation in high-performance electronics through open, closed, or hybrid configurations, implementing microchannels in cutting tools offers a promising strategy for enhancing machining performance and tool longevity. While MCHS studies emphasize material innovations and geometric optimizations to improve thermohydraulic efficiency, similar principles can be applied to cooling microchannels in machining tools.

Abid *et al.* (2019) investigated the implementation of microchannel configurations within internal-cooling cutting tools utilized for the machining of Inconel 718, underscoring their efficacy in augmenting thermal transfer efficiency. The research indicated that microchannels considerably diminish cutting temperatures, consequently inhibiting the formation of burrs and prolonging tool longevity. When juxtaposed with conventional flood cooling techniques, internal cooling exhibited markedly superior performance, with an elevation in coolant inlet pressure resulting in diminished cutting forces, lower temperatures, and enhanced surface quality. Advanced machine learning algorithms, including Random Forest (RF) and Support Vector Regression (SVR), were utilized to forecast critical parameters such as coolant inlet pressure and channel diameter, thereby optimizing the cooling procedure. The incorporation of microchannels into cutting tools yields considerable advantages by enhancing cooling efficiency, mitigating cutting forces, and improving surface quality, presenting a more effective and sustainable alternative to traditional flood cooling methodologies.

Singh and Sharma (2022) investigated the impact of internal cooling channels on turning tool performance, particularly for machining hard-to-machine materials. Their study highlights the crucial role of these channels in heat management, demonstrating that despite the introduction of internal cooling, the structural integrity of the tool remains largely unaffected, with a maximum stress variation of only 3.8%. The researchers employed Computational Fluid Dynamics (CFD) simulations to analyze the thermal effects of three different channel profiles, revealing that the introduction of coolant significantly lowers tool temperature. A maximum temperature drop of 188 K was observed compared to conventional tools without cooling channels, with variations between 20 K and 88 K depending on the channel profile. The study further established a direct correlation between the cooling effect and Turbulence Kinetic Energy (TKE), with both laminar and turbulent flow regimes influencing temperature reduction. Moreover, increasing the inlet pressure of the cutting fluid enhanced cooling efficiency, as higher flow velocity improved heat dissipation. These findings provide a foundation for optimizing cutting parameters in machining titanium alloys, offering a pathway to enhanced tool longevity and improved machining performance through strategic design of internal cooling channels.

Santra, Mukhopadhyay, and Chanda (2023) investigated the feasibility of engraving microchannels on the rake face of cutting tools to enhance the penetration of cutting fluid into the machining zone, which is typically difficult to access. Their research centered on a simulated analysis while machining mild steel with a high-speed steel (HSS) tool bit, assessing the structural integrity and stress distribution consequent to the integration of microchannels. The results indicated that despite the introduction of microchannels leading to an increase in the maximum principal stress experienced by the tool, the stress levels remained within the fracture threshold of the tool, thus validating the structural viability of the proposed design. Among the various microchannel configurations analyzed, trapezoidal microchannels demonstrated the most advantageous outcomes concerning stress distribution, whereas V-shaped channels yielded the least favorable performance. This study underscores the potential of microchannel engraving as a pioneering coolant delivery methodology, enhancing thermal dissipation and lubrication while preserving tool integrity, thereby contributing to improved machinability and thermal regulation in industrial machining applications.

Santra, Mukhopadhyay, and Chanda (2024) investigate the viability of inscribing microchannels onto uncoated tungsten carbide cutting instruments to augment coolant

distribution during the machining of Ti-6Al-4V. The research assesses an innovative microchannel-engraved tool featuring a negative rake angle by employing the maximum principal stress criterion under static loading conditions. The computational analysis scrutinizes variations in the geometry of microchannels and their proximity to the principal cutting edge (PCE) in order to evaluate stress distribution and overall tool efficacy. The findings reveal a direct relationship between the proximity of microchannels to the PCE and elevated levels of principal stress, underscoring the necessity for meticulous positioning. Trapezoidal and semi-circular microchannel designs demonstrate superior performance compared to rectangular configurations by facilitating a more uniform stress distribution, thereby mitigating localized stress concentrations. Notwithstanding the observed increase in stress with decreased proximity, all scenarios remained within the yield strength limits of tungsten carbide, thereby ensuring the safety of the tool. Optimal coolant distribution and structural integrity were attained with microchannels situated at a distance of 1.25 mm or greater from the PCE, thereby illustrating the feasibility for enhanced machining performance.

Wei *et al.* (2022) executed an extensive investigation into the significance of textured tools in enhancing machinability, with a particular focus on the mitigation of cutting forces and thermal effects. The study elucidates the manner in which microchannels, generated at the interface of the cutting tool and the workpiece, impact the penetration of coolant, subsequently influencing frictional dynamics and thermal dissipation. By employing a multiscale and multiphase theoretical framework, the research adeptly encapsulates the intricate interactions that occur between the machining operation, coolant flow within microchannels, and lubrication phenomena. The theoretical model, which was corroborated through orthogonal turning experiments conducted on Inconel 718, revealed that coolant infiltration into microchannels markedly improves cooling and lubrication, consequently leading to reductions in tool wear, cutting force, and contact length. Furthermore, the investigation utilized an integrated computational fluid dynamics (CFD) approach alongside the Johnson-Cook constitutive model to forecast temperature distributions and cutting forces. Notwithstanding its advantages, the research highlighted that the design of microchannels necessitates optimization to avert potential structural deficiencies in the cutting tool. The outcomes of this study significantly contribute to the progression of predictive modeling and the formulation of future cooling methodologies, including those utilizing cryogenic technologies.

Liao *et al.* (2020) carried out an analysis concerning the deployment of textured cutting tools aimed at optimizing machinability by diminishing cutting forces and thermal repercussions through a state-of-the-art multi-channel insert structure. The research tackled the intricate problem of lubricant delivery to the chip-tool interface, which exerts a considerable influence on friction, chip formation, and energy consumption during the machining processes of superalloys. By integrating macro-channels in close proximity to the cutting edge alongside interconnected micro-channels, the proposed tool enabled effective coolant penetration, thus creating a lubricating interface for chip movement. The experimental and modeling outcomes evidenced a 20% reduction in cutting force and specific energy, a 50% diminishment in adhesive wear, and a 30% decline in the friction coefficient. Enhanced chip fragmentation, reduced thermal generation, and the eradication of the white layer further corroborated the efficacy of the design. The results accentuate the promise of this innovative methodology for practical implementations while emphasizing the necessity for scalable manufacturing techniques such as powder metallurgy and texture imprinting technology.

Peng *et al.* (2019) conducted a rigorous investigation into the efficacy of an internal-cooling turning tool characterized by micro-channel configurations for the machining of Inconel 718. The research employed computational fluid dynamics (CFD) simulations to examine the impact of micro-channel diameter on the governing dynamics of coolant velocity and heat transfer. The optimal diameter of 2 mm was determined to facilitate the highest coolant velocity and promote effective cooling. The experimental validation encompassed a comparative analysis of dry cutting, traditional flood cooling, and internal cooling under uniform machining parameters. Notably, internal cooling at a pressure of 1.25 MPa resulted in a reduction of the principal cutting force by 19% in comparison to dry cutting and by 11.1% relative to flood cooling. The components of radial and feed forces exhibited decreases of 24% and 17.2% when juxtaposed with dry cutting, and reductions of 22.9% and 1.3% when compared to flood cooling. Furthermore, the cutting temperature experienced a decline of 172.9°C and 63.2°C in relation to dry and flood cooling, respectively.

Despite the mitigation of thermal loads, internal cooling was associated with an increase in surface roughness attributed to diminished and irregular chip contact length. Nevertheless, an escalation in inlet pressure was found to enhance machining quality by facilitating coolant penetration, thereby reducing surface roughness and ameliorating surface texture. Although the benefits exhibited diminishing returns at elevated pressures, this study underscores the

potential of internal cooling to augment machining efficiency and surface integrity in high-performance industrial applications.

High temperatures generated during machining processes pose significant challenges, including reduced tool life, compromised product quality, and increased energy consumption. Integrating microchannels into cutting tools offers a promising solution to these challenges by enabling localized cooling and minimizing coolant usage. Experimental studies have shown that microchannels with optimized geometries, such as slant rectangular ribs and double-row configurations, can significantly enhance heat dissipation. These designs not only improve thermal management but also contribute to the structural integrity and longevity of cutting tools. By leveraging the principles of microchannel cooling, the machining industry can achieve higher precision and productivity while reducing environmental impact. Thus, incorporation of microchannels in cutting tools may be considered as an alternative solution to mitigate the issue with heat generation and dissipation during machining.

2.6. Identified Research Gap

The literature highlights the transformative potential of microchannel heat sinks in modern thermal management. Their ability to achieve high heat flux dissipation with minimal coolant consumption makes them indispensable in various industries, from electronics to machining. Experimental and numerical studies have provided valuable insights into their design and performance, paving the way for future innovations. Future research should focus on overcoming fabrication challenges and exploring novel materials and geometries to further enhance the efficiency and applicability of microchannels. By building on these advancements, microchannels can revolutionize thermal management, ensuring sustainable progress across diverse technological domains.

A comprehensive review of existing literature highlights the ongoing research efforts aimed at developing advanced cooling methodologies that minimize coolant consumption in machining operations. With the emergence of novel materials designed to meet the evolving demands of modern industries, the need for effective cooling strategies has become increasingly critical. One of the primary challenges in machining lies in achieving efficient penetration of the cutting fluid into the plastic contact (C_p) region shown in Figure 2.1, where a high amount of heat is

generated. This issue remains an active area of research, as enhancing heat dissipation in this zone can substantially extend cutting tool life by mitigating tool wear and improving the surface quality of machined components.

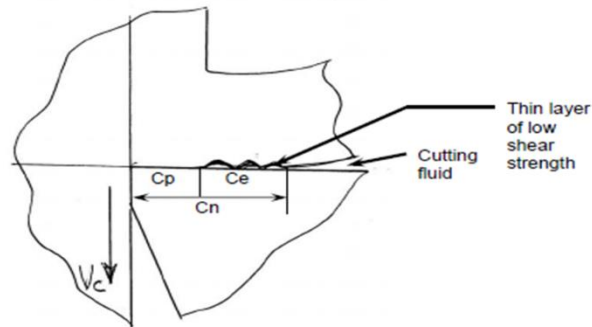

Figure 2.1 Cutting fluid action in machining (Mahata et. al. 2011)

Furthermore, previous studies have investigated coolant reduction strategies and the heat dissipation capabilities of microchannels, predominantly within the domain of miniaturized electronic devices requiring rapid thermal management. The demonstrated success of microchannels in such applications suggests their potential utility in machining, particularly in mitigating excessive tool heating, which detrimentally affects tool longevity, surface integrity, and overall machinability. By integrating microchannels into cutting tools, a viable approach to channeling cutting fluid efficiently into the C_p region can be realized, thereby improving heat transfer, reducing tool wear, and minimizing coolant usage.

The studied literature reveals the lack of comprehensive experimental and numerical investigations on microchannel-integrated cutting tools as an advanced cooling strategy for targeted heat removal in machining. Addressing this gap is essential for improving coolant efficiency, enhancing heat dissipation in the C_p region, and extending tool life while machining modern engineering materials. This novel approach is expected to contribute to optimizing machining performance, making it a relevant and impactful area of investigation.

2.7. Objective of the Study

The present investigation seeks to assess the feasibility and efficacy of engraving microchannels on cutting tools to augment thermal dissipation and optimize machining performance. The specific aims of the study are delineated as follows:

- **Validation of the Numerical Modelling Scheme for Detailed Analysis:** The study aims to validate the accuracy and reliability of the numerical simulation approach used for modeling and analyzing structural integrity in microchannel-integrated cutting tools.
- **Feasibility Analysis of Microchannel engraved HSS Cutting Tools for Machining Mild Steel:** Given that mild steel is extensively utilized in both industrial and domestic contexts, and high-speed steel (HSS) tools are frequently employed for its machining, this study scrutinizes the feasibility of HSS cutting tools featuring microchannels integrated on the rake face. The objective is to enhance coolant infiltration within the Cp region while maintaining the structural integrity of the cutting tool. Numerical simulations will be conducted to evaluate various geometric configurations of microchannels.
- **Feasibility Analysis of Microchannel engraved Tungsten Carbide (WC) Cutting Tools with Microchannels for Machining Ti-6Al-4V:** In response to the rising requirements for the machining of advanced materials such as Ti-6Al-4V, which present significant processing challenges, this investigation explores the feasibility of incorporating microchannels into uncoated tungsten carbide cutting tools. The objective is to evaluate the impact of various microchannel geometries on the structural integrity of the cutting tool and to refine the proximity of the microchannel in relation to the primary cutting edge.
- **Experimental Validation of the Proposed Cutting Tool Model:** The final objective encompasses the execution of experimental trials to validate the optimized microchannel-integrated cutting tool model, ensuring its practical applicability and effectiveness under actual machining conditions.

This research aims to comprehensively assess the structural integrity of cutting tools incorporating microchannels and their potential to significantly enhance heat dissipation. The findings are expected to contribute to extending tool life, improving machining performance, and reducing coolant consumption, addressing key challenges in modern manufacturing processes.

Chapter 3:

Materials and Methods

3. Introduction

The present study investigates the feasibility of microchannel generation on cutting tools without compromising with strength of the cutting tool to facilitate more penetration of cutting fluid within the Cp region of cutting zone. At first, the experiments are performed to validate the numerical model scheme at Cutting tool failure condition. Then Based on that platform, Numerical investigation is done on both HSS cutting tools models in the Second study and in the third study, uncoated tungsten carbide tool models which are microchannel engraved on the rake face to check feasibility of the designed tools in terms of strength. Lastly, in the Forth study, Experiments are done to validate the proposed optimized cutting tool model and check the performance in real machining condition. This chapter contains the details of the materials and methods used for the different study considered herein. The governing equations used in numerical analysis are as follows:

A. Equilibrium Equations (Force Balance)

The fundamental equations of motion for static equilibrium in the absence of inertia effects are given by the following differential form:

$$\frac{\partial \sigma_{xx}}{\partial x} + \frac{\partial \tau_{xy}}{\partial y} + \frac{\partial \tau_{xz}}{\partial z} + f_x = 0 \quad (i)$$

$$\frac{\partial \tau_{yx}}{\partial x} + \frac{\partial \sigma_{yy}}{\partial y} + \frac{\partial \tau_{yz}}{\partial z} + f_y = 0 \quad (ii)$$

$$\frac{\partial \tau_{zx}}{\partial x} + \frac{\partial \tau_{zy}}{\partial y} + \frac{\partial \sigma_{zz}}{\partial z} + f_z = 0 \quad (iii)$$

Where:

- $\sigma_{xx}, \sigma_{yy}, \sigma_{zz}$ are **normal stresses**
- $\tau_{xy}, \tau_{yz}, \tau_{zx}$ are **shear stresses**
- f_x, f_y, f_z are **body forces** per unit volume

B. Strain-Displacement Relations (Kinematics)

The strain components in terms of displacement are defined as:

$$\varepsilon_{xx} = \frac{\partial u}{\partial x}, \varepsilon_{yy} = \frac{\partial v}{\partial y}, \varepsilon_{zz} = \frac{\partial w}{\partial z} \quad (iv)$$

$$\gamma_{xy} = \frac{\partial u}{\partial y} + \frac{\partial v}{\partial x}, \gamma_{yz} = \frac{\partial v}{\partial z} + \frac{\partial w}{\partial y}, \gamma_{zx} = \frac{\partial w}{\partial x} + \frac{\partial u}{\partial z} \quad (v)$$

Where:

- u, v, w are **displacement components** in x, y, z directions
- $\varepsilon_{xx}, \varepsilon_{yy}, \varepsilon_{zz}$ are **normal strains**
- $\gamma_{xy}, \gamma_{yz}, \gamma_{zx}$ are **shear strains**

C. Constitutive Relations (Hooke's Law for Linear Elasticity)

For an **isotropic, linear elastic material**, the stress-strain relationship (Hooke's Law) is expressed as:

$$\sigma_{xx} = \frac{E}{(1 + \nu) + (1 - 2\nu)} [(1 - \nu)\varepsilon_{xx} + \nu(\varepsilon_{yy} + \varepsilon_{zz})] \quad (vi)$$

$$\sigma_{yy} = \frac{E}{(1 + \nu) + (1 - 2\nu)} [(1 - \nu)\varepsilon_{yy} + \nu(\varepsilon_{xx} + \varepsilon_{zz})] \quad (vii)$$

$$\sigma_{zz} = \frac{E}{(1 + \nu) + (1 - 2\nu)} [(1 - \nu)\varepsilon_{zz} + \nu(\varepsilon_{xx} + \varepsilon_{yy})] \quad (viii)$$

$$\tau_{xy} = G\gamma_{xy}, \tau_{yz} = G\gamma_{yz}, \tau_{zx} = G\gamma_{zx}$$

Where:

- E is **Young's modulus**
- ν is **Poisson's ratio**
- $G = \frac{E}{2(1+\nu)}$ is **shear modulus**

D. Principal Stresses Calculation

The **principal stresses** $\sigma_1, \sigma_2, \sigma_3$ are determined by solving the characteristic equation of the stress tensor:

$$\det|\sigma_{ij} - \lambda\delta_{ij}| = 0 \quad (ix)$$

The **Maximum Principal Stress** is given by:

$$\sigma_{max} = \max(\sigma_1, \sigma_2, \sigma_3) \quad (x)$$

E. Maximum Total Deformation

The **Total Deformation** or **magnitude of displacement** vector is computed as

$$U_{total} = \sqrt{u^2 + v^2 + w^2}$$

where u, v, w are the displacements in the respective directions.

3.1 Numerical Model Validation

A conventional lathe was used to machine mild steel using a negatively raked cutting tool made of AISI M2 high-speed steel (HSS) for experimental analysis. To mitigate the difficulties associated with creating microchannels on the rake face, high-speed steel was chosen as the tool substrate, widely adopted in the manufacturing sector. Mild steel has predominantly been the subject of significant research as a work material in conjunction with HSS for studies pertaining to machinability. A strain gauge-type dynamometer was utilized to measure the cutting force components along three mutually perpendicular axes. The measurement system demonstrated a maximum percentage error of less than 5%, with repeatability confined within 1% across repeated trials, indicating high precision and reliability of the data acquisition.

During machining, cutting tools are typically subjected to multi-axial stress conditions. When these stresses reach certain critical levels, tool failure can occur. The threshold at which this failure happens largely depends on factors such as the tool material, the workpiece material, and various process parameters. Therefore, evaluating the stress state within the cutting tool is essential for predicting potential tool failure.

In the current investigation, a rigid cutting tool has been employed to execute orthogonal machining processes aimed at the generation of continuous chips, with the workpiece material being characterized as elastic-viscoplastic. An experimental study was conducted, involving variations in cutting speed, feed rate, and depth of cut, to explore the critical combination of process parameters that lead to tool failure. The cutting parameters along with their corresponding force components related to tool failure are presented in Table 3.1.

The values obtained from the tool failure analysis are subsequently applied in a static structural analysis facilitated by software simulation. In the analysis, the cutting forces were assumed to act upon the nose of the cutting tool as uniformly distributed loads, as suggested by Cakir and Yahya (2005). Experimental data, including the cutting parameters and the respective cutting forces recorded at the moment of tool failure, are detailed in Table 3.1. During the analytical process, the cutting forces are regarded as uniformly distributed loads exerting influence on the nose of the cutting tool.

To validate the numerical scheme, the failure condition of the cutting tool is numerically checked by the maximum principal stress failure criteria as shown in equation (i). The Maximum Principal Stress (MPS) Failure Criterion, also known as the Rankine Criterion, posits that failure in a material occurs when the maximum principal stress (σ_1) material's ultimate tensile strength (σ_{ut}). Mathematically, this is expressed as:

$$\sigma_1 \geq \sigma_{ut} \quad \dots\dots\dots (i)$$

For brittle materials, which have negligible plastic deformation before failure, the MPS criterion provides an accurate assessment of material behavior under tensile loading conditions. The material fails when the highest principal stress at any point surpasses the ultimate tensile strength, regardless of the state of stress in other directions.

While the Maximum Principal Stress (MPS) criterion is straightforward and effective for predicting failure in brittle materials, its applicability must be considered in relation to other commonly used failure theories. The Maximum Shear Stress (Tresca) criterion, primarily applicable to ductile materials, emphasizes yielding governed by shear stress and may not accurately predict brittle failure, where tensile stresses are more critical. Similarly, the Von Mises criterion, also suited for ductile materials, is based on distortional energy and does not account for the tensile fracture mechanisms characteristic of brittle materials. The Mohr-Coulomb criterion, commonly used for geo-materials like soils and rocks, incorporates both

shear and normal stresses but relies on additional parameters such as cohesion and internal friction angle, which may not be easily obtainable for all brittle materials. In contrast, the MPS criterion's simplicity and direct focus on tensile stress make it particularly appropriate for brittle materials, where fracture typically occurs due to tensile stress concentrations. The applicability of the MPS criterion to brittle failure has been effectively demonstrated in the study by Leckie and Bello (2009).

3.2 Methodology for Evaluating Structural Integrity of Microchannel Engraved HSS Cutting Tools in Mild Steel Machining

Based on the validated numerical model, simulations were conducted utilizing the optimized cutting force components under two comparative conditions: with and without microchannel structures. The computational workflow employed in this study is outlined in Figure 3.2.1, and the detailed geometry of the designed cutting tool is presented in Figure 3.2.2.

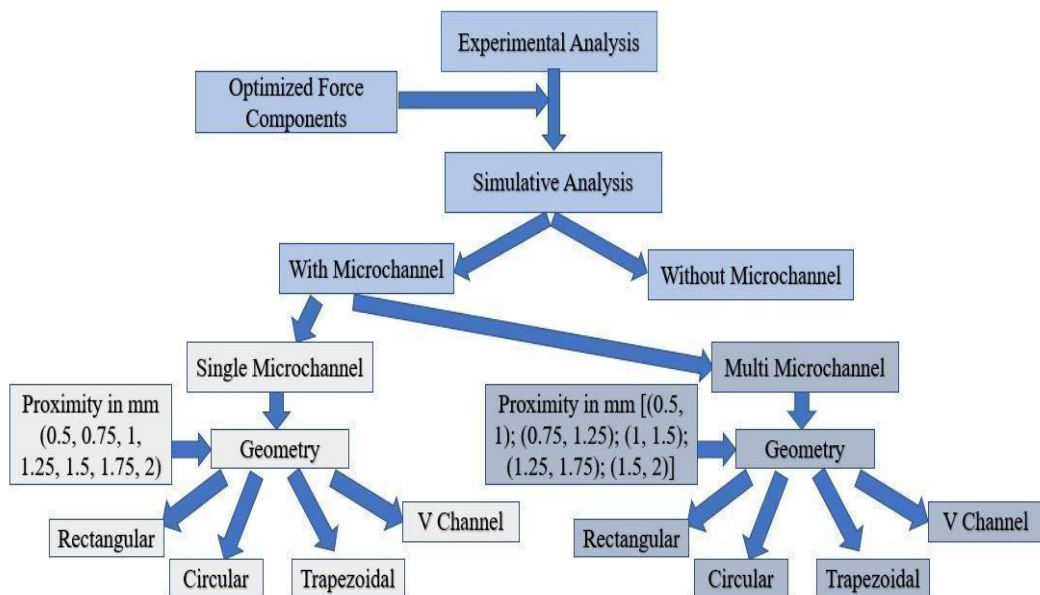
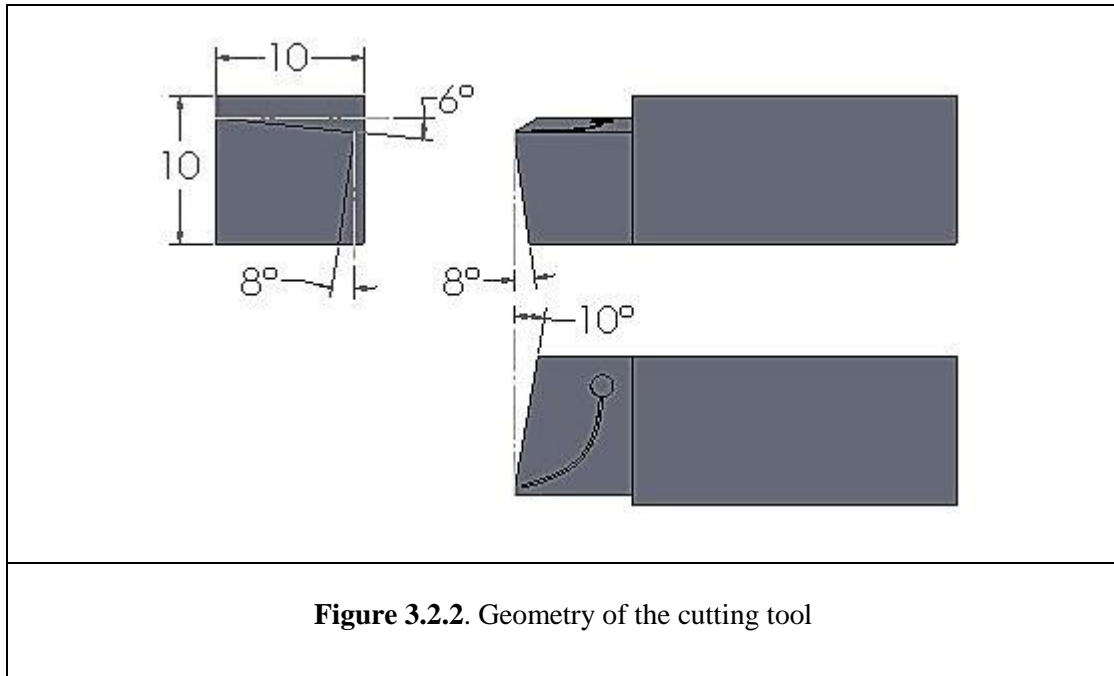

Figure 3.2.1 Flowchart of the study



Conditional simulations were executed utilizing Ansys software to ascertain the maximum principal stress induced within the designed model. The designed tool possesses a negative rake angle and exhibits characteristics akin to the cutting tool employed in conducting machining operations. The analyses conducted were predicated on the optimized conditions adjudged for the experimental assessments carried out by varying the speed and feed parameters in a dry machining context. A numerical structural stress analysis was conducted on the designed single point turning tool subsequent to the execution of a preliminary grid independence assessment. The final mesh and the outcomes of the grid independence assessment conducted are illustrated in Figure 3.2.3 and Figure 3.2.4.

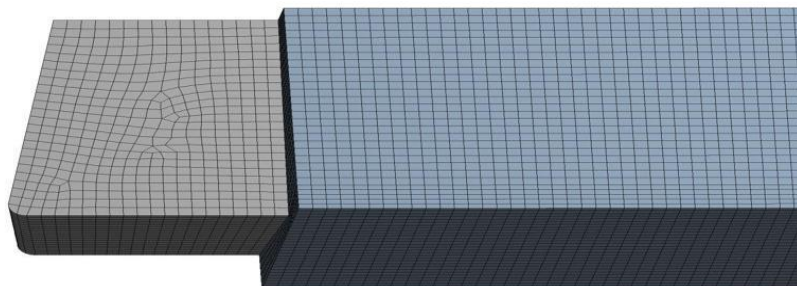

Figure 3.2.3 Final mesh of the cutting tool

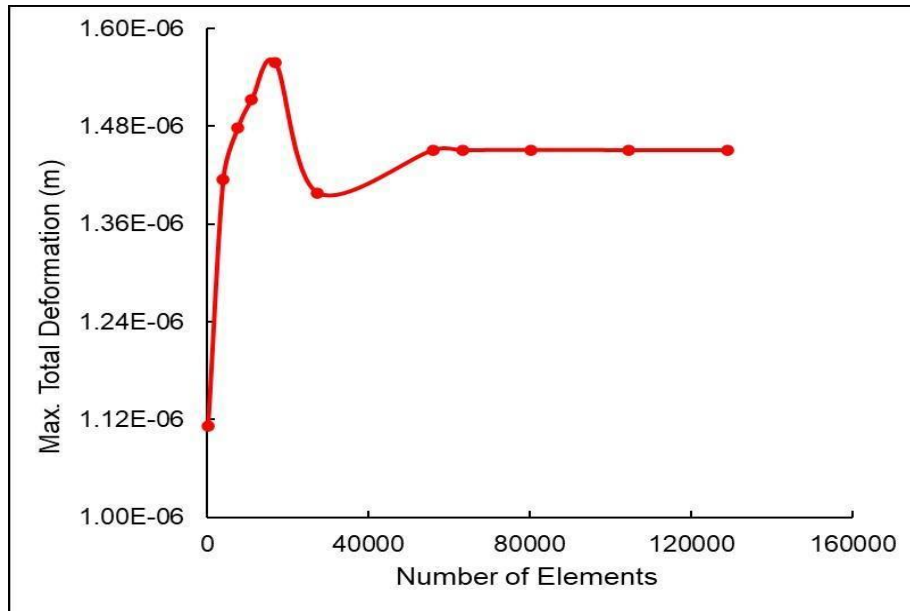

Figure 3.2.4 Result of the grid independence test

Simulative analysis was conducted on single point turning tool without microchannel and with microchannel having different geometries and proximity. The proximity of the microchannel were determined based on the elastic and plastic contact region of the chips flowing over the rake surface of the single point turning tool. The change in geometry of the microchannel were provided to identify the change in tool strength for different cross sections.

Table 3.1. Details of the study

Lathe Machine Tool	Make: H. P. Singh Machinery Pvt. Ltd. Model: 6FT (V-Belt Driven Lathe)
Force Dynamometer	Make: Testmaster Model: UILD 15 Capacity: 500 kgf (3 directional components) Least count: 0.1 kgf
Force Indicator	Make: Testmaster Model: UIL 15

Process parameters and its corresponding Force components for tool failure validation	Cutting Velocity: 161.6 m/min Feed rate: 0.1 mm/rev Depth of Cut: 1 mm Feed Force (F_x) = 90 N, Cross Feed Force (F_y) = 530 N Cutting Force (F_z) = 790 N
Tool Nomenclature	ASA System: 0 -- -6 – 8 – 8 – 10 – 0 – 1/5
Cutting Parameters	Cutting Velocity: 20, 25 and 30 m/min Feed rate: 0.10, 0.125 and 0.15 mm per revolution Depth of cut: 1 mm
Optimized Cutting force components	Feed Force (F_x) = 15 N, Cross Feed Force (F_y) = 80 N Cutting Force (F_z) = 120 N
Thermal Properties	Cutting Tool: AISI M2 HSS Specific Heat Capacity: 0.460 J/g-°C Thermal Conductivity: 28-33 W/m-K Workpiece: Mild Steel Specific Heat Capacity: 0.460 J/g-°C Thermal Conductivity: 50 W/m-K
Design Software	Solidworks 2016
Analysis Software	Ansys 2020 R1 (static structural)
Shape of Microchannel	Rectangular Semicircular Trapezoidal V cross section
Proximity of Single microchannel from PCE	0.5 mm, 0.75 mm, 1 mm, 1.25 mm, 1.5 mm, 1.75 mm & 2 mm
Proximity of Multi (Double) microchannel from PCE	0.5 mm & 1 mm, 0.75 mm & 1.25 mm, 1 mm & 1.5 mm, 1.25 mm & 1.75 mm, 1.5 mm & 2 mm
Mesh size	Element size: 0.0004m Number of elements: more than 80000

The selection of various cross-sectional micro-channels has been conclusively determined based on prior research. In the current investigation, four distinct configurations (namely, V-shaped, semicircular, rectangular, and trapezoidal) of micro-channels have been chosen, as the fabrication of these specific micro-channel designs is facilitated through different micro-machining techniques, and existing literature indicates that these configurations exhibit superior performance regarding heat transfer efficiency. Given the inherent brittleness of the cutting tool material, the maximum principal stress failure criterion has been employed for the fracture analysis of a single-point cutting tool that incorporates microchannel grooves on the tool rake, subjected to specified loading conditions. The comprehensive details of the study, including the boundary conditions implemented in the numerical simulations and the geometrical specifications of the microchannels utilized, are presented in Table 3.1 and Figure 3.2.5, respectively.

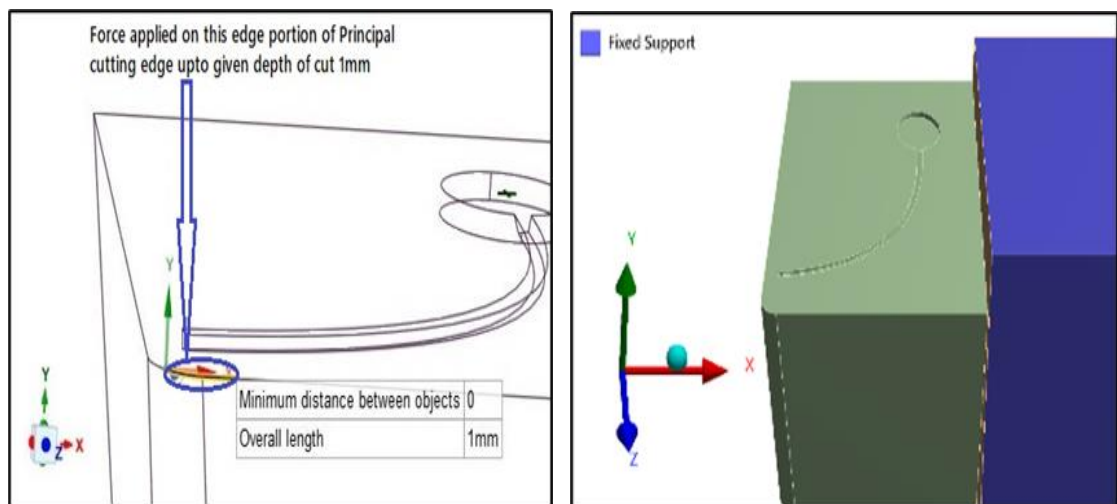

Figure 3.2.5 (a) Boundary conditions of numerical simulation

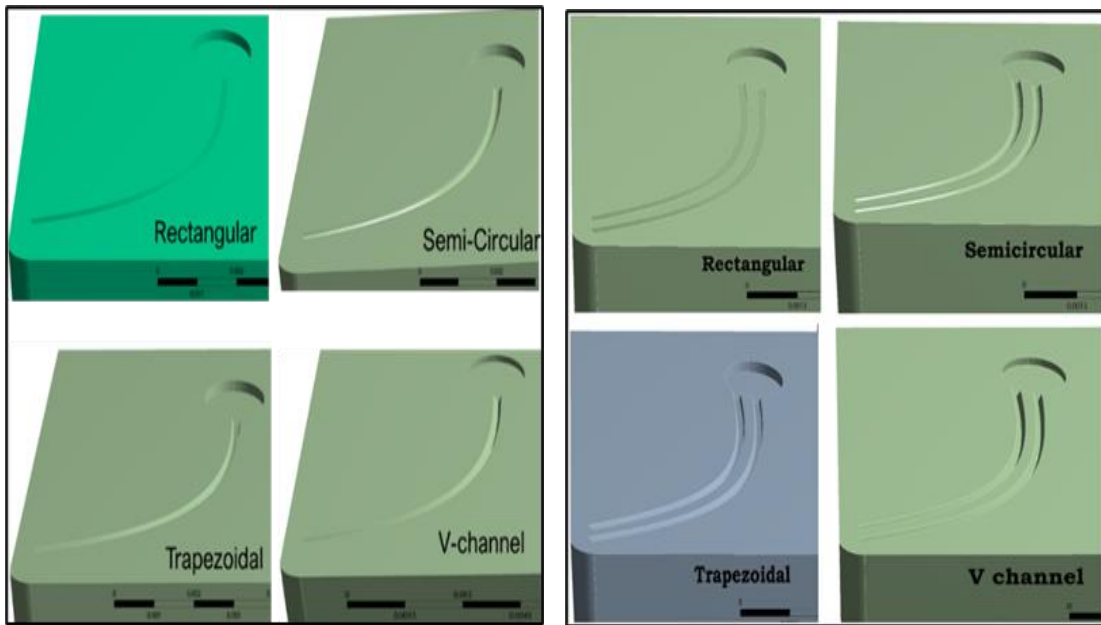

Figure 3.2.5 (b) Single and multi-microchannels

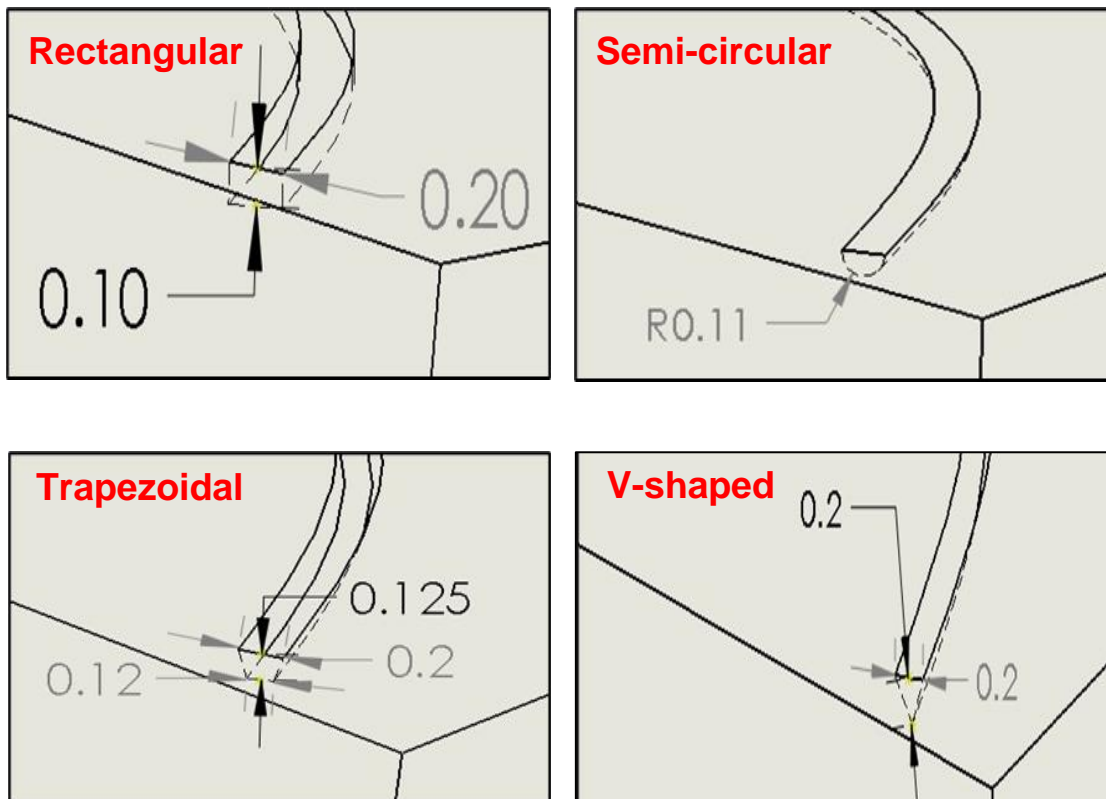

Figure 3.2.5 (c) Cross section of different microchannels

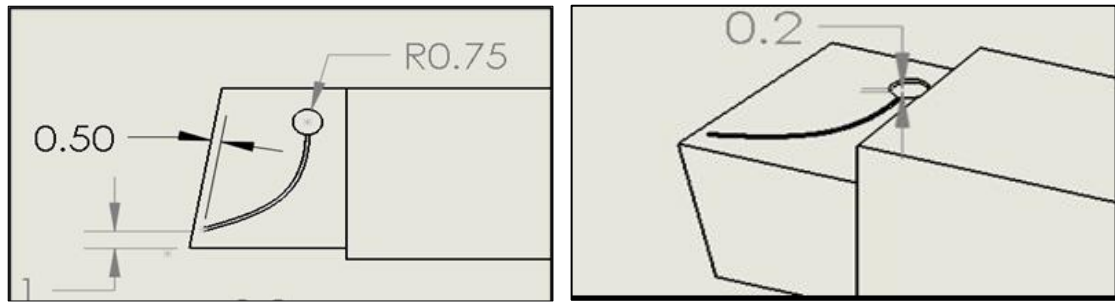

Figure 3.2.5 (d) 2D profile of a single microchannel positioned 1 mm from PCE & 0.5 mm from ACE

Figure 3.2.5. Boundary conditions of numerical simulations and the geometrical specifications of the microchannels

3.3 Simulation Strategy for Uncoated WC Tools with Microchannels in Machining of Ti-6Al-4V

Following the preliminary investigation, a series of numerical analysis were carried out to estimate the maximum principal stress induced in an uncoated tungsten carbide (WC/Co) cutting tool during the machining of a difficult-to-machine (DTM) Ti-6Al-4V alloy. To begin with, the employed model underwent validation through the application of the variation in cutting forces derived from the initial study, along with the findings articulated by Cakir and Yahya (2005). The consistency of the material properties was upheld in accordance with earlier research endeavors. The validation process yielded satisfactory outcomes, wherein the simulated value exhibited a deviation of 1.53% from the material's ultimate tensile strength (UTS), thereby substantiating the suitability of the established failure criteria. The obtained results are illustrated in Figure 3.3.1 (a) & (b).

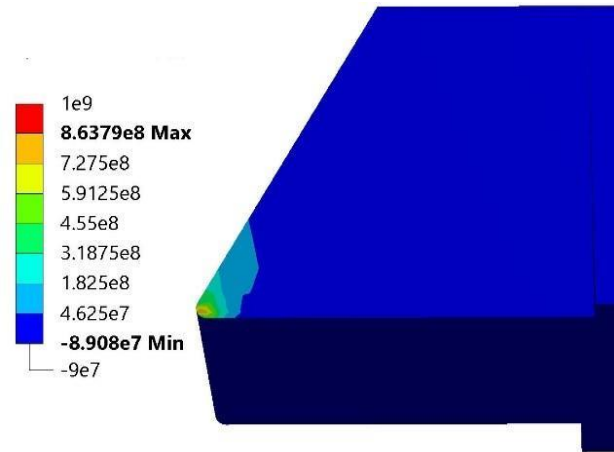

Figure 3.3.1 (a) Result of numerical study utilizing the force components leading to the failure of the cutting tool

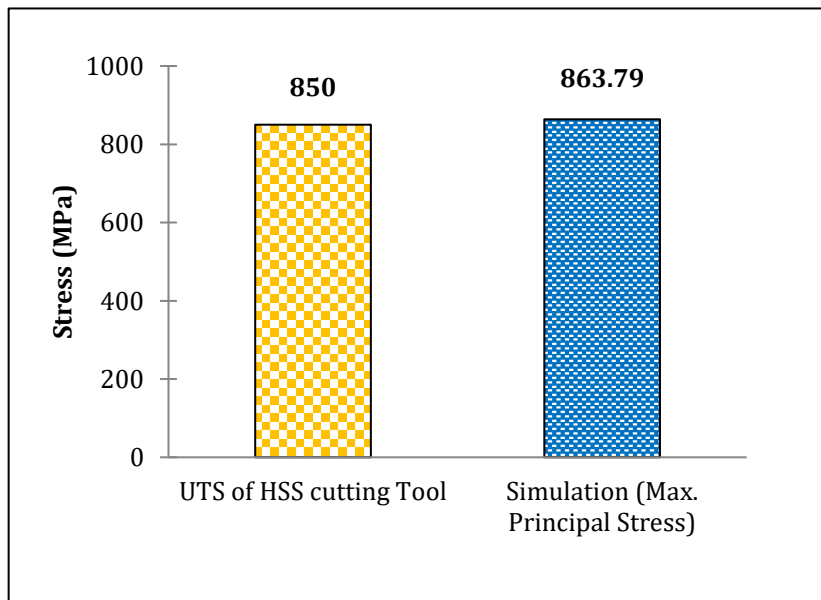

Figure 3.3.1 (b) Comparative analysis between Simulated Maximum Principal stress and Ultimate Tensile Strength of cutting tool material

The validated numerical methodology is subsequently employed for the numerical investigation conducted on tungsten carbide tool, encompassing both microchannel-engraved and non-microchannel-engraved tools as analyzed in the current research. Microchannels exhibiting diverse geometrical cross-sections, namely rectangular, semicircular, and trapezoidal forms, were meticulously designed on the tool rake at varying distances from the

principal cutting edge (PCE). The operational flow diagram of the process is illustrated in Figure 3.3.2 (a). The proximity of the microchannels was assessed by considering the elastic and plastic contact regions of the chips as it flowing across the rake face of the tool. The selection of microchannel geometries was predicated upon previously reported enhancements in performance concerning strength and thermal transfer, as evidenced by preliminary study and research conducted by Bhandari *et al.* (2023) and Deng *et al.* (2018).

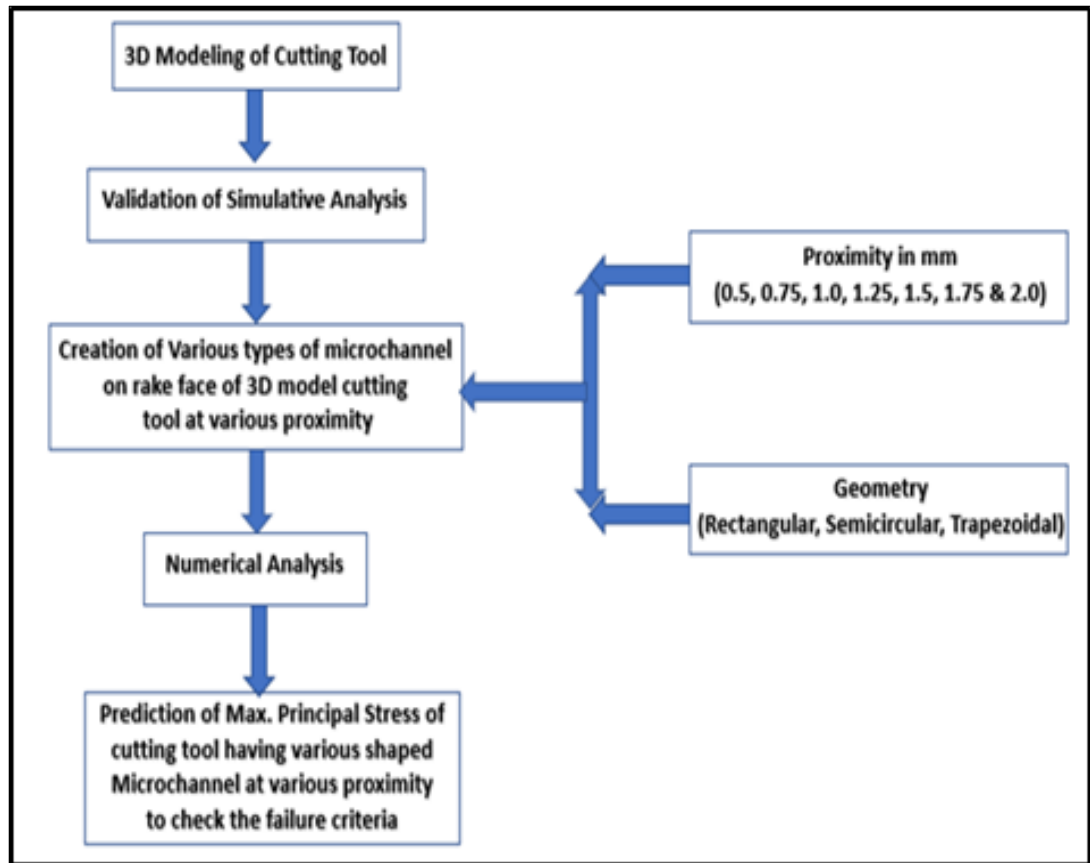

Figure 3.3.2 (a) Study Flow Diagram

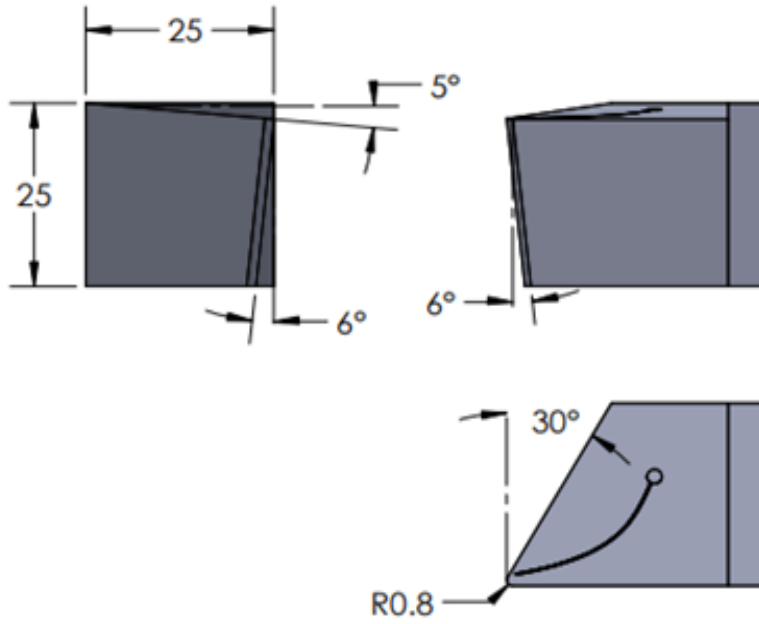

Figure 3.3.2. (b) Tool Geometry

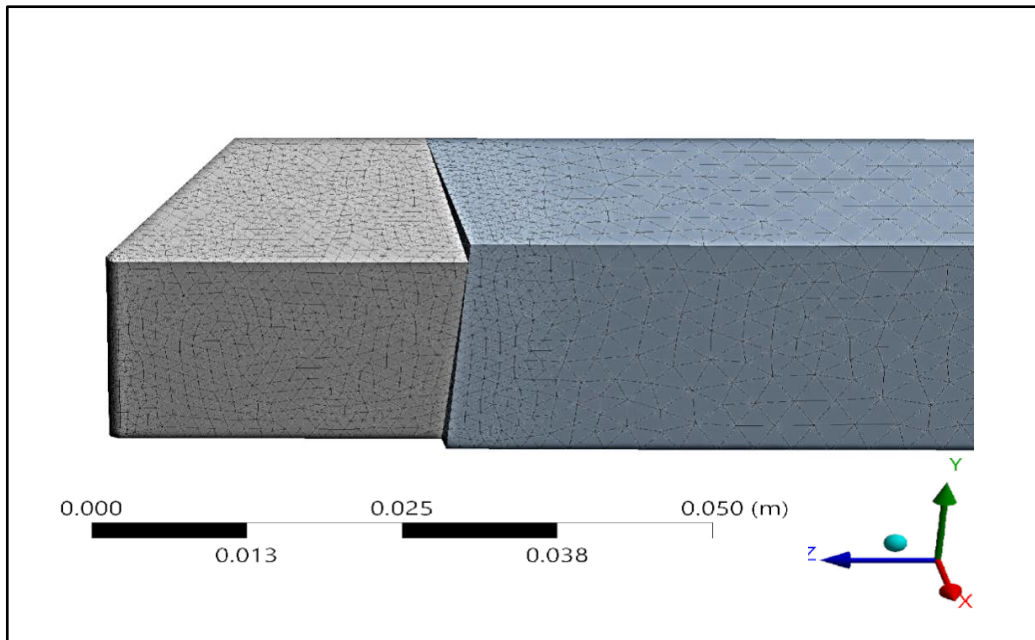

Figure 3.3.2. (c) Mesh geometry of the cutting tool

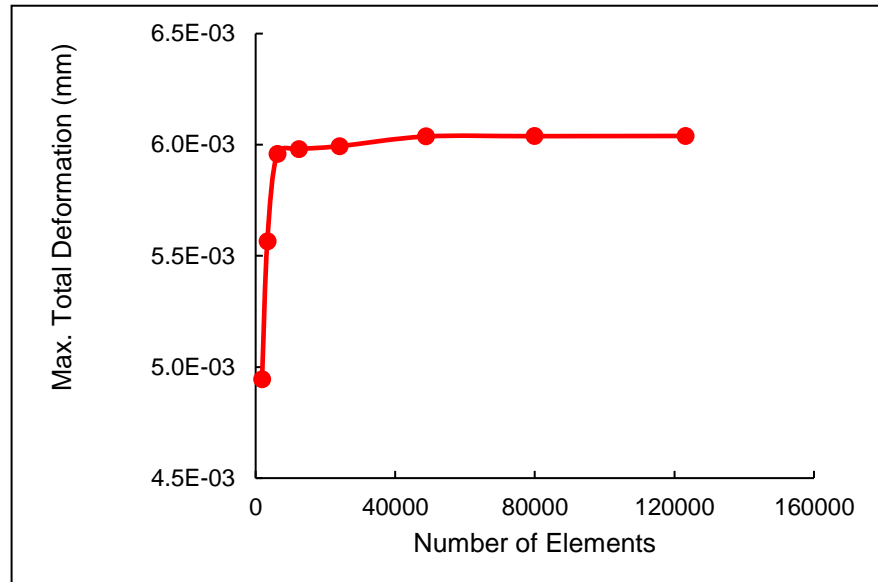

Figure 3.3.2 (d) Grid independence assessment

Detailed three-dimensional model of the considered cutting tool has been generated using and industrially accepted design software (SolidWorks 16), ensuring careful attention to dimensions and material properties reported by Cakir and Yahya (2005). This model is served as the basis for subsequent finite element analysis, where the tool's strength was predicted under the given loads i.e. feed force (F_x) of 172 N, cross feed force (F_y) of 380 N, cutting force (F_z) of 756 N and conditions suggested by Özel *et al.* (2010), focusing on the maximum principal stress failure criterion. The considered static components of cutting force are subjected to be acting on an isotropic WC/Co tool material. Simulative analysis was performed on the various tool designed for critical analysis of maximum principal stress and maximum total deformation.

The geometry of the considered cutting tool is given in Figure 3.3.2 (b). For expository analysis of static structure Ansys 2020 R1 was employed after carrying out a primary grid independence test as shown in Figure 3.3.2 (c) & (d). Maximum principal stress failure criteria were employed for numerical analysis of the considered negative raked single point uncoated tungsten carbide (WC/Co) as the material has higher brittleness. The maximum principal stress criterion was chosen because the carbide tool is classified as a brittle material, for which this criterion is more relevant and accurate in predicting failure. The material properties and other parameters considered for cutting tool is provided in Table 3.2. Figure 3.3.3 shows the boundary conditions and geometry of the microchannels used for the present study. The size of the micro-channels was decided by considering a fixed cross-sectional area while maintaining the same top width

of the micro-channel. This approach ensures uniform flow characteristics and consistent performance across the microchannel network.

Table 3.2: Details of the study

Material Properties	Cutting Tool: Uncoated Tungsten Carbide Density: 15.7 g/cm ³ Poisson’s ratio: 0.28 Yield strength 2683 N/mm ² Young’s modulus: 683 kN/mm ² Workpiece: Ti – 6Al – 4V Density: 4.4 g/cm ³ Poisson’s ratio: 0.3 Yield strength 820 N/mm ² Young’s modulus: 114 kN/mm ²
Mesh Elements	Number of elements: more than 100000 Type of Meshing elements: Tetrahedral

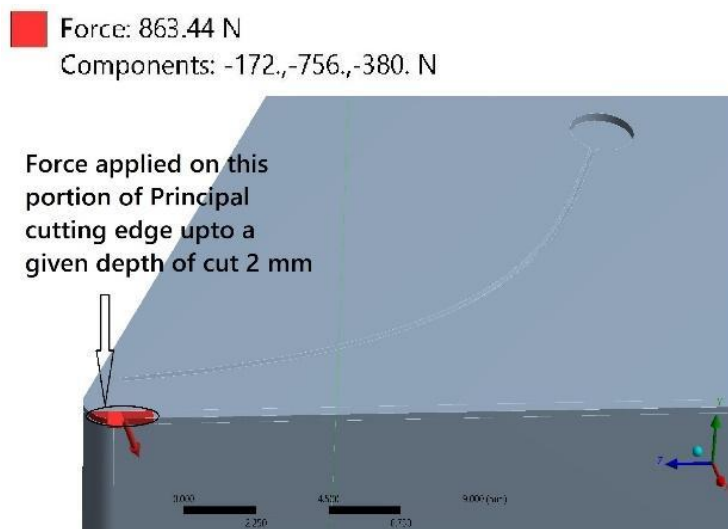

Figure 3.3.3 (a) Boundary conditions of applied Force for numerical simulation

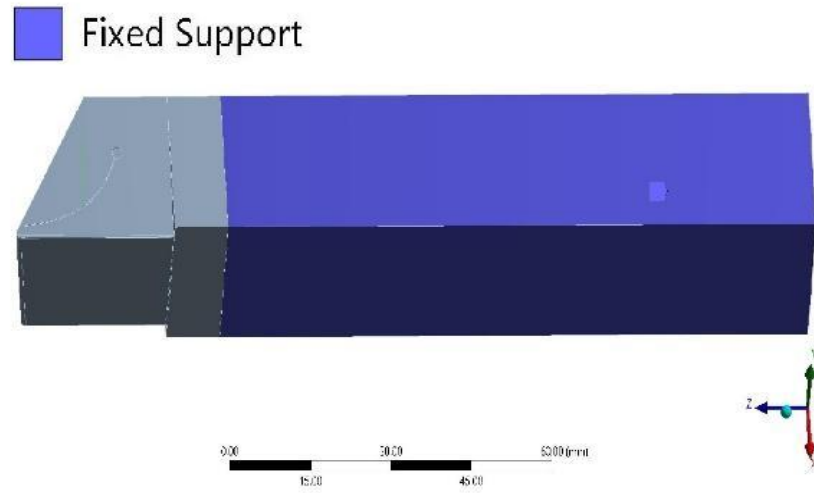

Figure 3.3.3 (b) Boundary conditions of Fixed support for numerical simulation

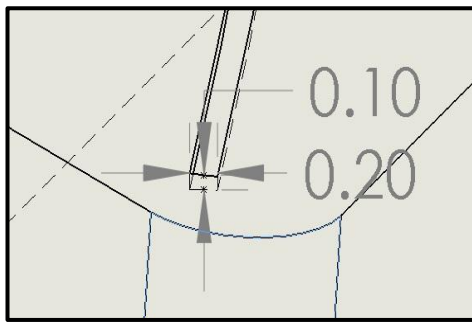

Figure 3.3.3 (c) Rectangular microchannel

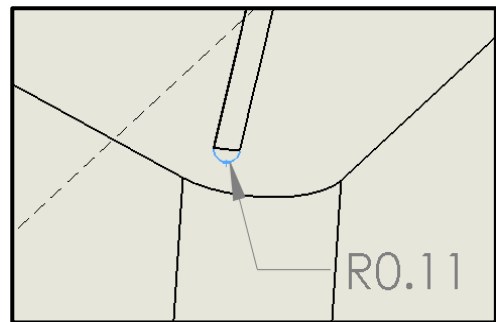

Figure 3.3.3 (d) Semi-circular microchannel

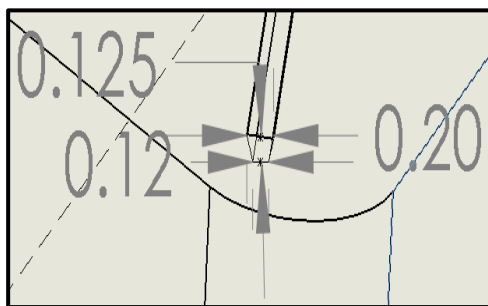

Figure 3.3.3 (e) Trapezoidal microchannel



Figure 3.3.3 (f) 2D profile of single microchannel

3.4 Integrated Experimental and Simulation Approach for Validating Optimized Tool Microchannel Designs.

The fourth study involves an experimental analysis of the machining of mild steel using an M42-grade high-speed steel (HSS) cutting tool under different cooling conditions, including dry machining, MQL, and cooling through microchannels. This investigation aims to assess the feasibility and performance of microchannel-textured cutting tools under real machining conditions. Following the experimental study, a numerical analysis was conducted using the optimized cutting force values obtained from the experiments. This analysis evaluates the stress-bearing capacity of the designed cutting tool, providing insights into its structural integrity and performance under machining loads. In the experimental study, turning operation was carried out on a mild steel cylindrical bar of 41 mm diameter using an HMT NH-26 lathe machine. To investigate the effect of varying cutting velocities, six numbers of M42-grade high-speed steel (HSS) cutting tool was employed while keeping the feed rate (0.10 mm/rev) and depth of cut (0.7 mm) constant. Cutting velocities of 24.7 m/min, 41.8 m/min, and 54.1 m/min were employed under both dry and SQL environments, using a total of six cutting tools, to enable a comprehensive assessment of machining performance across varying speed conditions. The detailed experimental configuration and parameters are provided in Fig. 3.4.1 and Table 3.3.

To enhance the performance of the cutting tool, microchannels were introduced on the rake face using an Aradhana 20W laser engraving machine. Although laser engraving typically produces triangular cross-section microchannels, a novel trapezoidal cross-section microchannel was designed and fabricated in this study. The engraving operation was performed by scanning the laser in parallel passes to generate precise and repeatable channel geometries. Trapezoidal microchannels of identical design were fabricated on six M42-grade HSS cutting tools, positioned at two selected proximities from the principal cutting edge—1.0 mm (three tools) and 1.5 mm (three tools). The details of these configurations are as follows:

Case 1: A 300 μm deep and 200 μm wide microchannel was positioned 1 mm from the principal cutting edge and 0.5 mm from the auxiliary cutting edge. One end of the channel was connected to a coolant reservoir to facilitate fluid flow.

Case 2: A 300 μm deep and 200 μm wide microchannel was placed 1.5 mm from the principal cutting edge and 0.5 mm from the auxiliary cutting edge. Similar to Case 1, one end of the channel was linked to a reservoir to ensure fluid supply.

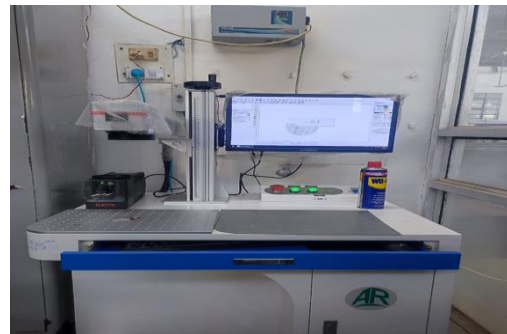
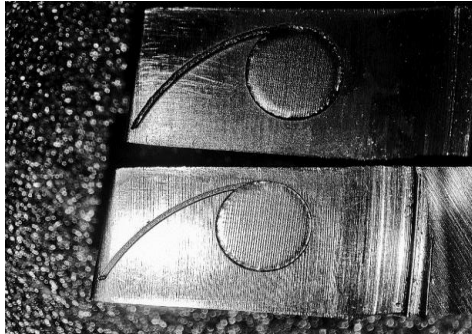

Figure 3.4.1 (a). Tool with micro-channel **Figure 3.4.1 (b).** Laser engraving machine

Table 3.3. Experimental study details

Cutting tool	Brand: Miranda Tool material: M42 High speed steel Shank cross-section: 6.35 mm \times 6.35 mm
Laser Engraving Machine	Laser wavelength: 10.55 μm to 10.63 μm Laser repeating frequency: 20-95 KHz Standard working area: 110*110 mm Focal length: 172 mm Engraving speed: Up to 7000 mm/sec Repeat positioning accuracy: +/-0.002 mm Power supply: AC 110V/220V +/-10%, 50 Hz
Work material	Material: Mild steel Dimensions: 41 mm diameter and 300 mm length
Coolant	Blasocut 2000 in 1:20 ratio (Mukhopadhyay & Kundu 2018)
Surface roughness tester	Make: Mitutoyo, Japan Model: SURFTEST SJ-500 SV-2100
Thermal camera	Make: Fluke, Germany Model: TiS75+ Max. Temp.: 550°C
Slide Calliper	Make: Mitutoyo, Japan Model: N15 Least count: 0.02 mm

During the turning operation, coolant was manually injected into the reservoir using a syringe. As machining progressed, the high temperature at the cutting zone led to vaporization of the coolant, indicating that fluid transport within the microchannel was likely influenced by capillary action. This mechanism played a crucial role in maintaining lubrication and cooling at the tool-chip interface. To assess the impact of microchannels on machining performance, several key parameters were measured:

- I. Cutting forces were recorded using a dynamometer to evaluate tool-workpiece interaction.
- II. Maximum temperature at the machining zone was monitored using a thermal camera, providing insights into heat dissipation efficiency.
- III. Surface roughness of the machined workpiece was measured post-experiment using a Mitutoyo surface roughness tester, ensuring a quantitative evaluation of machining quality.

The optimized force values obtained from the experimental studies were further utilized to conduct a numerical simulation to examine the stress distribution on the cutting tool having identical geometric features and material properties. A 3D model of the cutting tool was first created using SolidWorks as shown in Fig. 3.4.2.

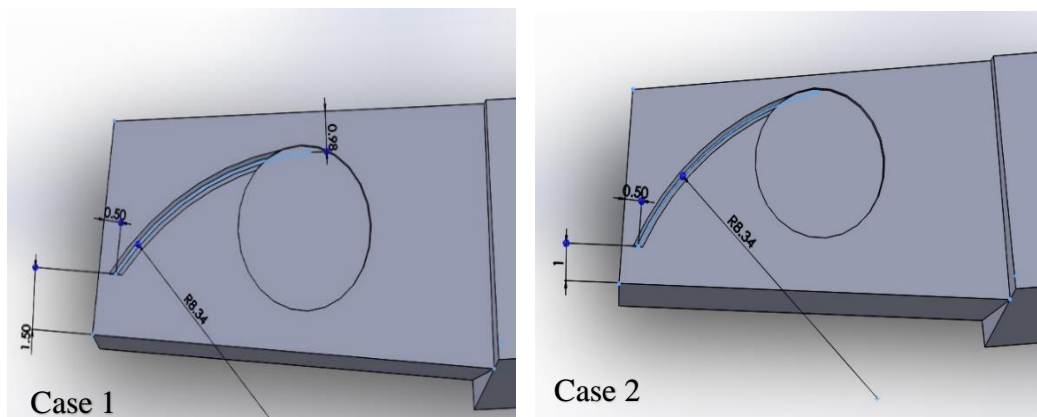

Figure 3.4.2. Geometry of Microchannel

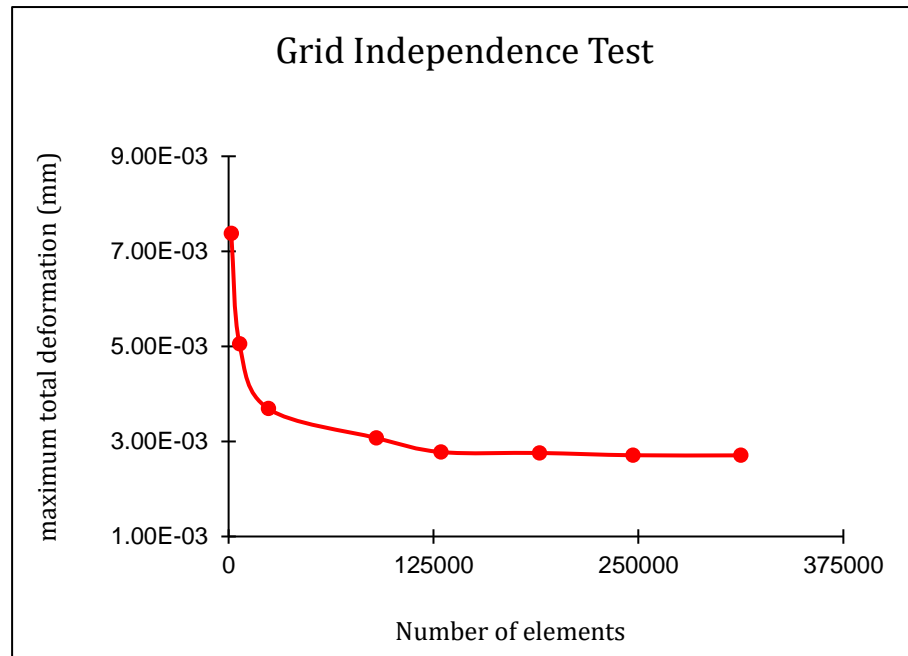

Figure 3.4.3 Grid Independence test results

For numerical analysis of proposed cutting tool, Ansys 2020 R1 static structural scheme was employed after carrying out a primary grid independence test as shown in Figure 3.4.3. To check the stress distribution and feasibility, Maximum principal stress criteria was employed.

Chapter 4:

Results and Discussions

4.1 Introduction

This chapter presents a systematic analysis of the structural and functional performance of microchannel-textured cutting tools through both numerical simulations and experimental validation. The study begins with the verification of the finite element model against experimental failure data, confirming its suitability for stress analysis. Structural assessments of HSS and tungsten carbide tools investigate the influence of microchannel geometry and proximity to the principal cutting edge on stress distribution and deformation. Finally, experimental trials on M42 HSS tools under dry, SQL, and microchannel-assisted conditions evaluate cutting forces, temperature, and surface quality. The integrated findings establish the structural feasibility and machining benefits of optimized microchannel designs for advanced and sustainable manufacturing.

4.2 Validation of the Numerical Modelling Scheme for Detailed Analysis

The first section of the present study deals with the Experimental investigation of HSS Cutting tool for machining mild steel workpiece to achieve the critical force value for tool failure and then the obtained critical force value subsequently applied in a static structural analysis facilitated by software simulation to validate the Numerical model scheme for accuracy and reliability by considering maximum principal stress failure criteria. Figure 4.2.1 illustrates the simulation results derived from the force components acquired through experimental analysis, under which the cutting tool experienced failure. As depicted in Figure 4.2.2, the results obtained for the maximum principal stress exceed the ultimate tensile strength of the material, thereby indicating that the tool fractures under critical force conditions. Given that the forces represent the measured values at the point of tool failure, this serves as a robust indicator that the metal cutting process, as predicted by the finite element model, demonstrates a close alignment with experimental results. Therefore, from the obtained result it can be seen that the adopted numerical model scheme is well validated with the real experimental results.

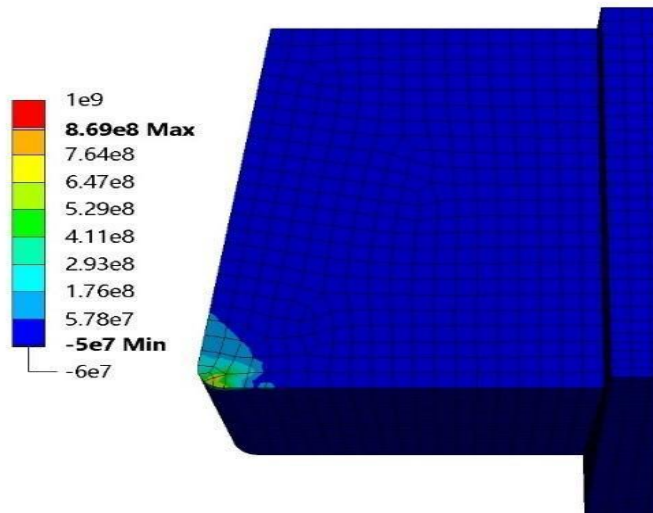

Figure 4.2.1. Result of simulative analysis using the force components under which the cutting tool failed

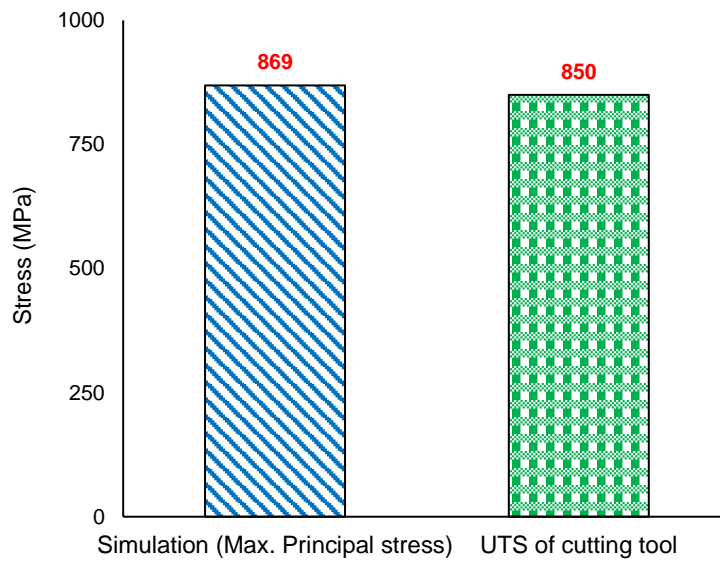

Figure 4.2.2. Comparison of simulated maximum principal stress and UTS of cutting tool material

4.3 Feasibility Analysis of Microchannel engraved HSS Cutting Tools for Machining

Mild Steel

Simulative structural strength analysis of the designed single point turning tool were performed under two conditions, viz., with microchannel and without microchannel. Figure 4.3.1 presents a comparative view of the maximum principal stress on the cutting tool with various single microchannel grooved at a various proximity from Principal cutting edge to analyse the change in tool strength. For all the cases values of stress concentration were found to be higher at the region near the tool tip and portion of microchannel nearer to PCE (as shown in Figure. 4.3.1) due to surface irregularities generated because of microchannel grooved on rake face. Most unfavourable case has been seen for V shaped microchannels, where the maximum principal stress reached up to 1.42E+02 MPa, while the microchannel was closest to PCE. The most favourable results were obtained for trapezoidal microchannel at the proximity of 2 mm from the cutting edge.

The observed trend can be attributed to the stress concentration factor, which is the magnitude of stress is amplified in the vicinity of a stress enhancer (such as a microchannel) compared to the stress that would be present in the absence of the stress raiser. In general, stress concentration factors are affected by the geometry of the stress raiser, the loading conditions, and the material properties.

In the case of a trapezoidal cross section microchannel over a rake surface of HSS single point cutting tool under static loading, the stress concentration factor is relatively low due to the gradual change in geometry along the length of the channel (Narvydas and Puodžiūnienė, 2012; Neuber, 1961). As a result, the stress distribution is relatively uniform and the maximum principal stress is lower than in other types of microchannels. In contrast, in the case of a V-channel microchannel over a rake surface of HSS single point cutting tool under static loading, the stress concentration factor is relatively high due to the sharp change in geometry at the bottom of the channel (Gross and Mendelson, 1972; Noda and Takase, 2003). This results in a highly localized stress distribution and the maximum principal stress is higher than in other types of microchannels.

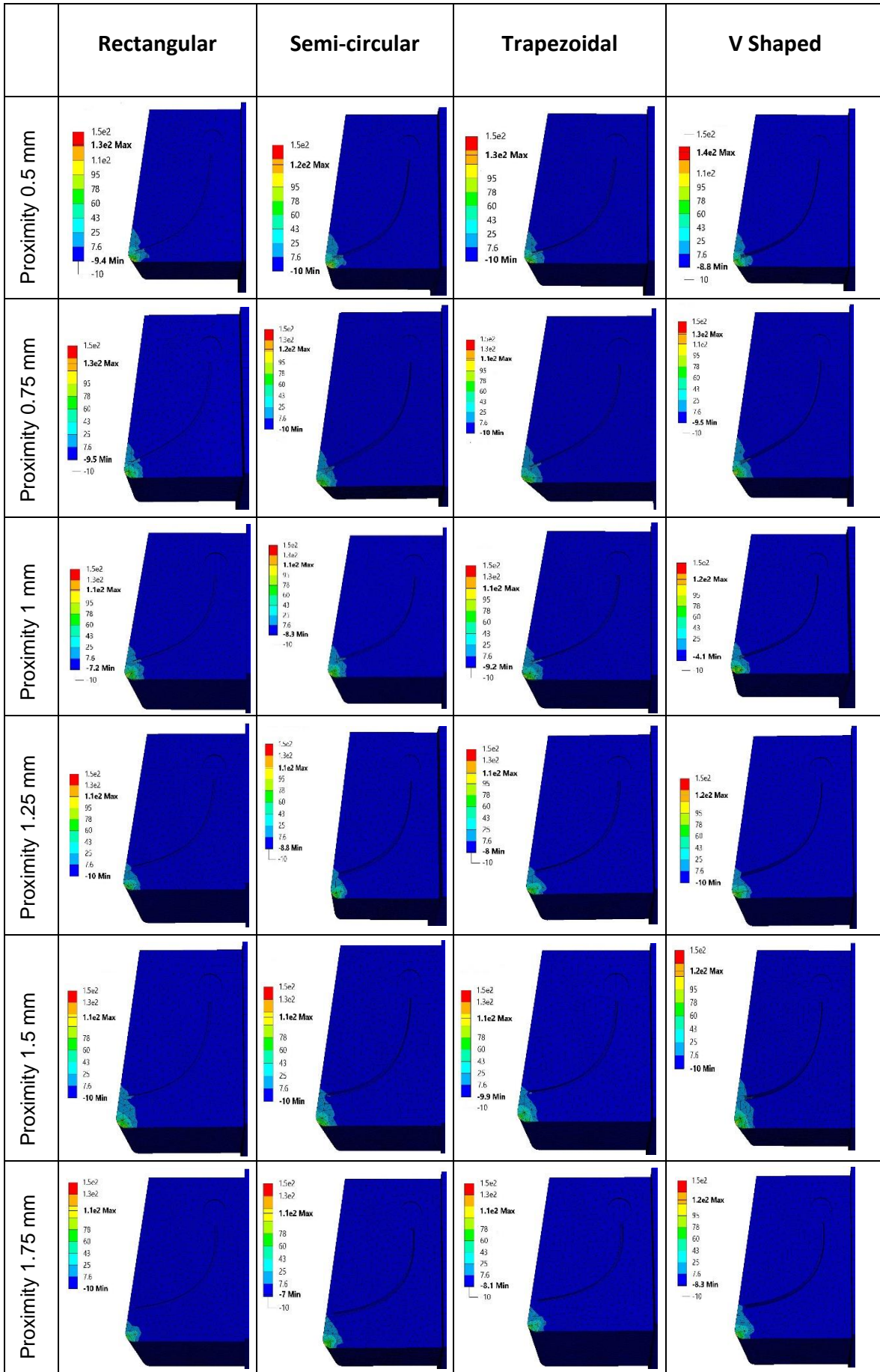

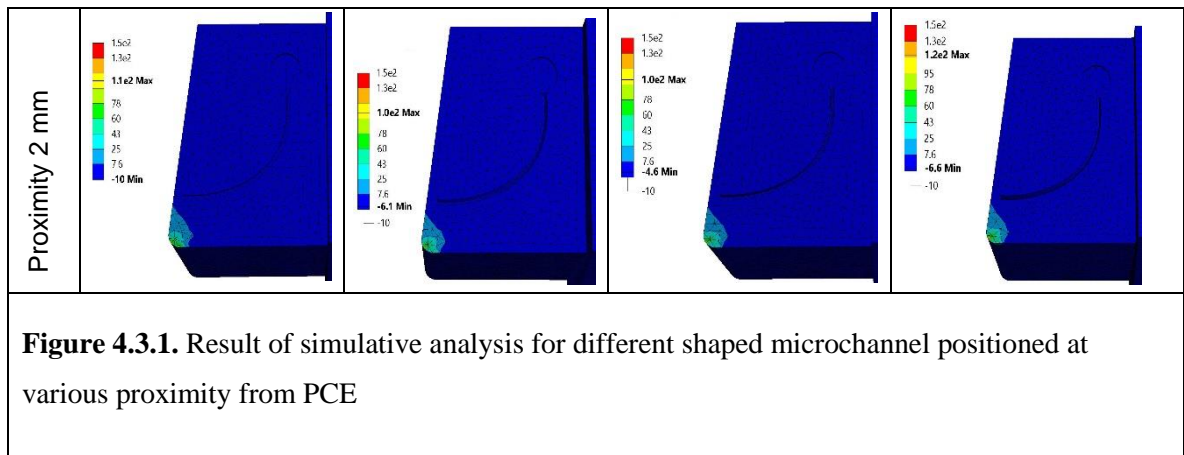

In Figure 4.3.2 the trend indicates that maximum principal stress for cutting tool with single microchannel is nearly 5% to 25% higher in comparison with cutting tool without microchannel. It can be apprehended that due to microchannel generation on tool rake face maximum principal stress developed in the cutting tool is expected to be higher. However, for all the cases, maximum principal stress is significantly lesser than the ultimate tensile strength of the cutting tool material. Therefore, as per maximum principal stress failure theory, cutting tools found to be safe for the considered components of cutting forces (Leckie and Bello, 2009).

Obtained results point out that proximity of the generated microchannel will directly contribute to higher stress development within the cutting tool and will shoot up with reduction of its distance from PCE. The figure also gives an impression V shaped and rectangular shaped microchannels perform poorly, owing to the localised stress generated due to abrupt changes in geometrical shape. More favourable performance is expected for trapezoidal and semi-circular microchannels while being meandered on tool rake due to less amount of localised stress generation in comparison to other two geometrical shapes. Because in case of trapezoidal and semi-circular microchannels, the stress lines become more uniform at the corner points with respect to other two geometrical configurations (Noda *et al.*, 1995; Walter *et al.*, 2008; Neuber, 1961; Glinka, 1985). Results show that maximum principal stress for Trapezoidal microchannel varies from 125.1 MPa to 102.1 MPa with respect to various proximity of microchannel from the principal cutting edge of the cutting tool. It is also found that the value of maximum principal stress is quite closer in case of Semi-circular microchannel with a maximum variation of 1.5 % greater with respect to Trapezoidal microchannel. Whereas the maximum principal stress is higher in case of Rectangular microchannel varies around 2% to

10% and in case of V shaped microchannel varies around 10% to 14% with respect to Trapezoidal microchannel.

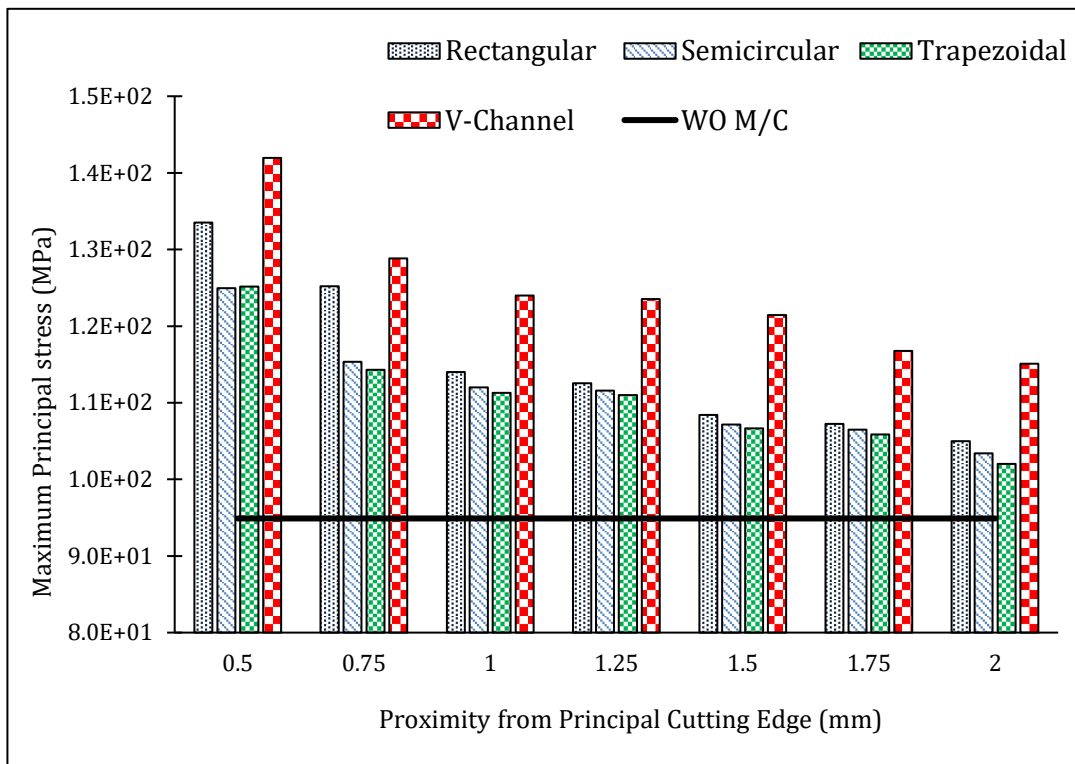
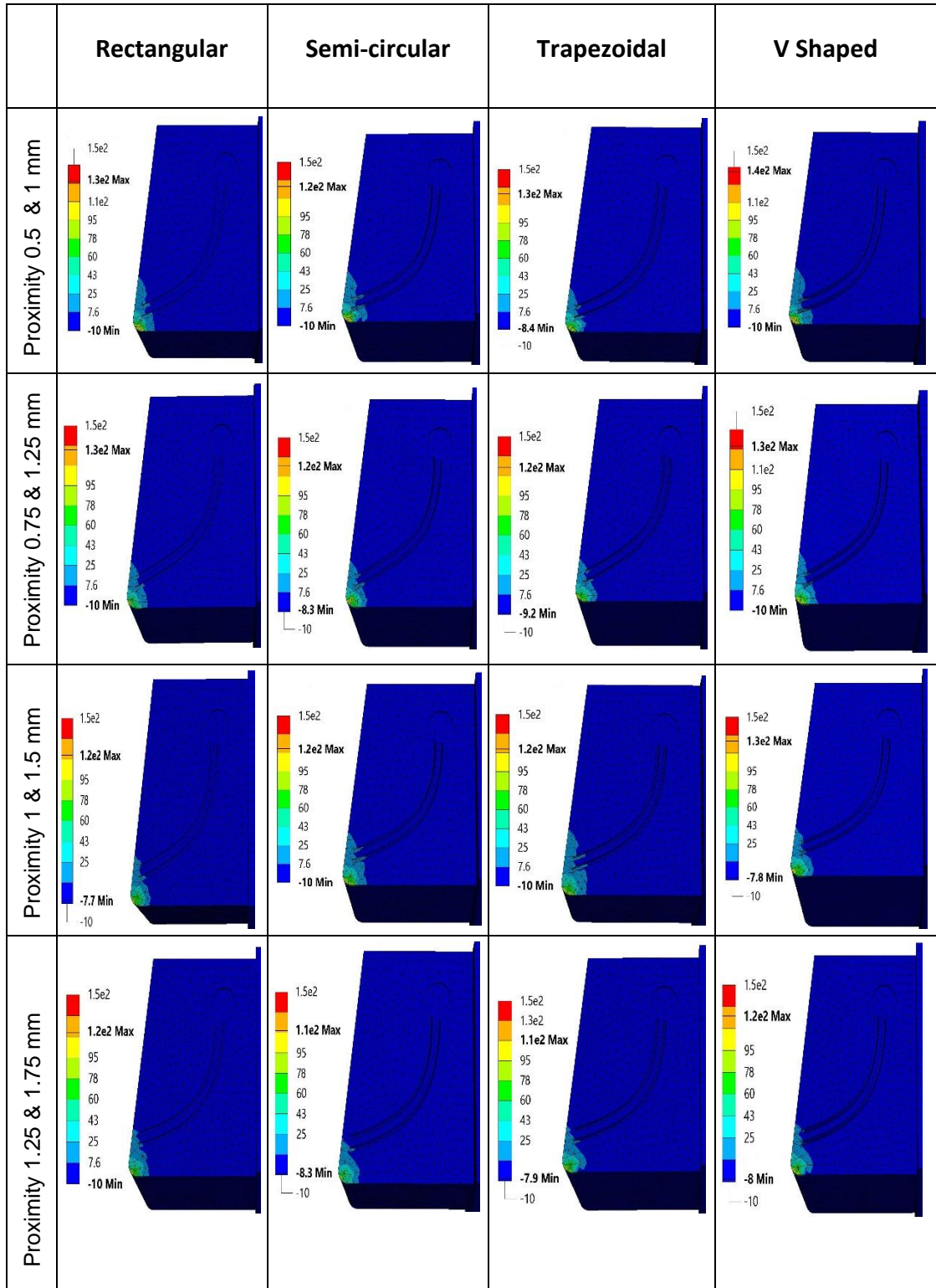

Figure 4.3.2. Variation of maximum principal stress for single microchannel under varying proximity to PCE (datum level for maximum principal stress is 8.0E+01 MPa)

Corresponding static structural analysis of cutting tool having single microchannel, study focused on the possibility of multiple microchannel for better heat dissipation. However, with increased number of microchannels the chance of failure of cutting tool also increases. Figure 4.3.3 presents a comparative view of the maximum principal stress on the single point turning tool with various multi (double) microchannel grooved at various proximity condition to check the tool strength. The trends observed are similar to the ones obtained for single microchannel, where V shaped microchannel resulted in higher principal stress values compared to others.

Figure 4.3.3 shows that Trapezoidal microchannel provided with the most satisfactory value of maximum principal stress, having a magnitude of 1.08E+02 MPa while being at the farthest from the PCE among the proximities considered. It can be observed that the obtained stress values for multi-microchannel setup is comparatively higher than its single microchannel counterpart, however, all the stress values obtained are well within the flexure point of the cutting tool material.



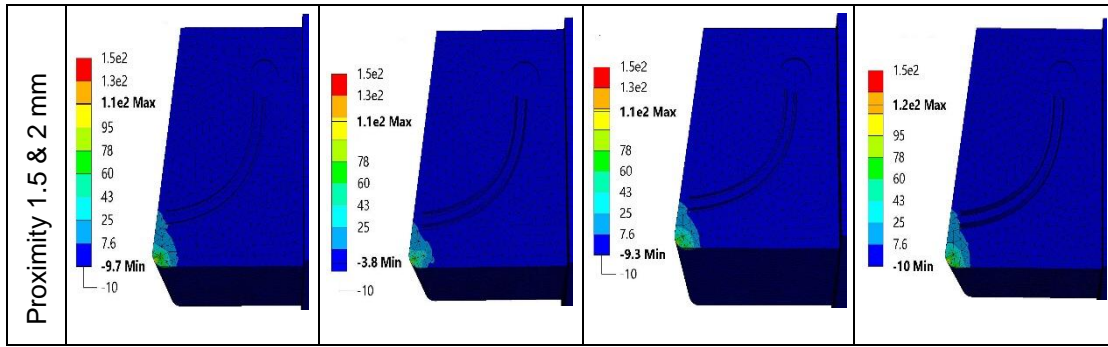

Figure 4.3.3. Result of simulative analysis for different shaped multi microchannel positioned at various proximity from PCE

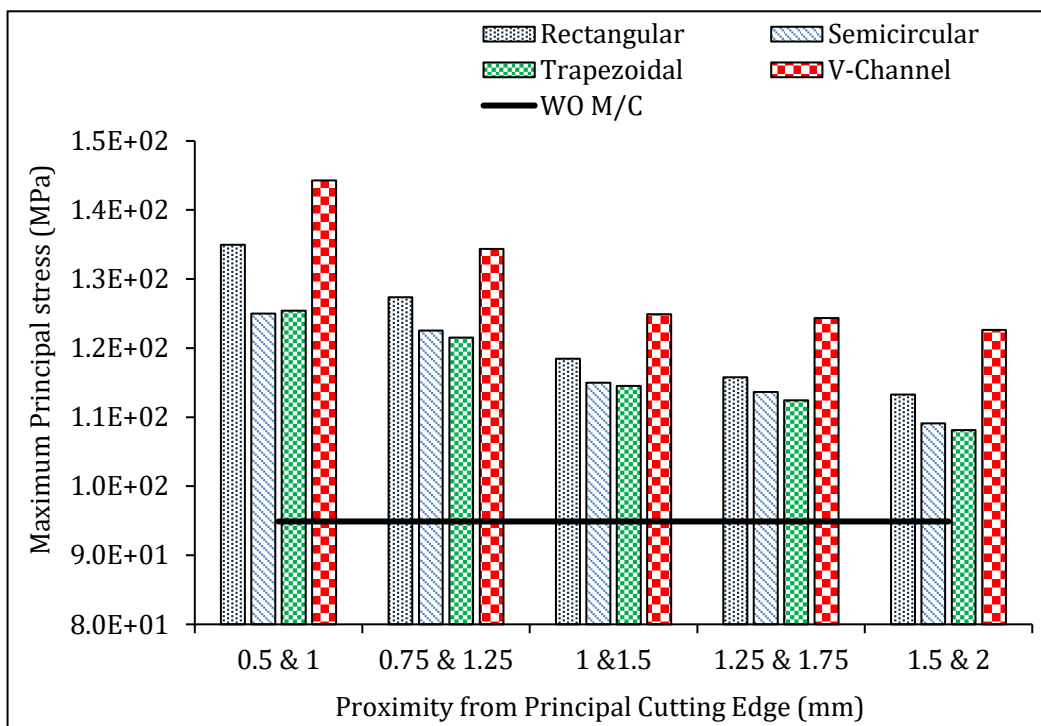

Figure 4.3.4. Variation of maximum principal stress for multi microchannel under varying proximity to PCE (datum level for maximum principal stress is 8.0E+01 MPa)

The results obtained from Figure 4.3.4. suggests about the possibility of this multi microchannel array for enhancing fluid flow and effective heat dissipation from the machining zone. The figure also gives an impression about the unfavourable performances of V shaped and rectangular shaped multi microchannels similar to single microchannel. Results show that maximum principal stress for multi microchannel having Trapezoidal cross section varies from 125.4 MPa to 108.1 MPa with respect to various proximity of microchannel from the principal

cutting edge of the cutting tool. It is also found that the value of maximum principal stress is quite closer in case of multi microchannel having semi-circular cross section with a variation of maximum 1 % greater with respect to Trapezoidal microchannel. Whereas the maximum principal stress is higher in case of multi microchannel having rectangular cross section varies around 2% to 8% and having V shaped cross section varies around 9% to 15% with respect to multi microchannel having trapezoidal cross section.

4.4 Feasibility Analysis of Microchannel engraved Tungsten Carbide (WC) Cutting Tools with Microchannels for Machining Ti-6Al-4V

The structural strength of the turning tool was analysed through simulation under various considered condition and is depicted in Figure 4.4.1. The stress concentration values were consistently higher in the vicinity of the tool-tip and the section of the microchannel closer to the PCE for all conditions, as depicted in the figure. This elevation in stress concentration can be attributed to surface irregularities arising from the existence of microchannels on the rake face (Neuber, 1961; Glinka, 1985). Notably, the most favourable outcome was observed while a trapezoidal microchannel positioned at a proximity of 2 mm from PCE.

This discernible pattern can be elucidated by analysing the stress concentration, a metric indicating the extent to which stress is intensified near the region of stress infliction (microchannel), in contrast to the stress subjected in absence of the microchannel. The stress concentration factor is influenced by various factors, including the geometric configuration of the stress affliction region, region subjected to cutting force, and properties of material. For microchannel having trapezoidal cross-section, rake face of an uncoated tungsten carbide Single Point Turning Tool (SPTT) subjected to static loading, stress concentration squats, owing to the gradual geometric changes along the channel's length. Consequently, the stress distribution is more uniform, resulting in a lower maximum principal stress compared to other types of microchannels (Noda *et al.*, 1995; Narvydas and Puodžiūnienė, 2012; Glinka, 1985).

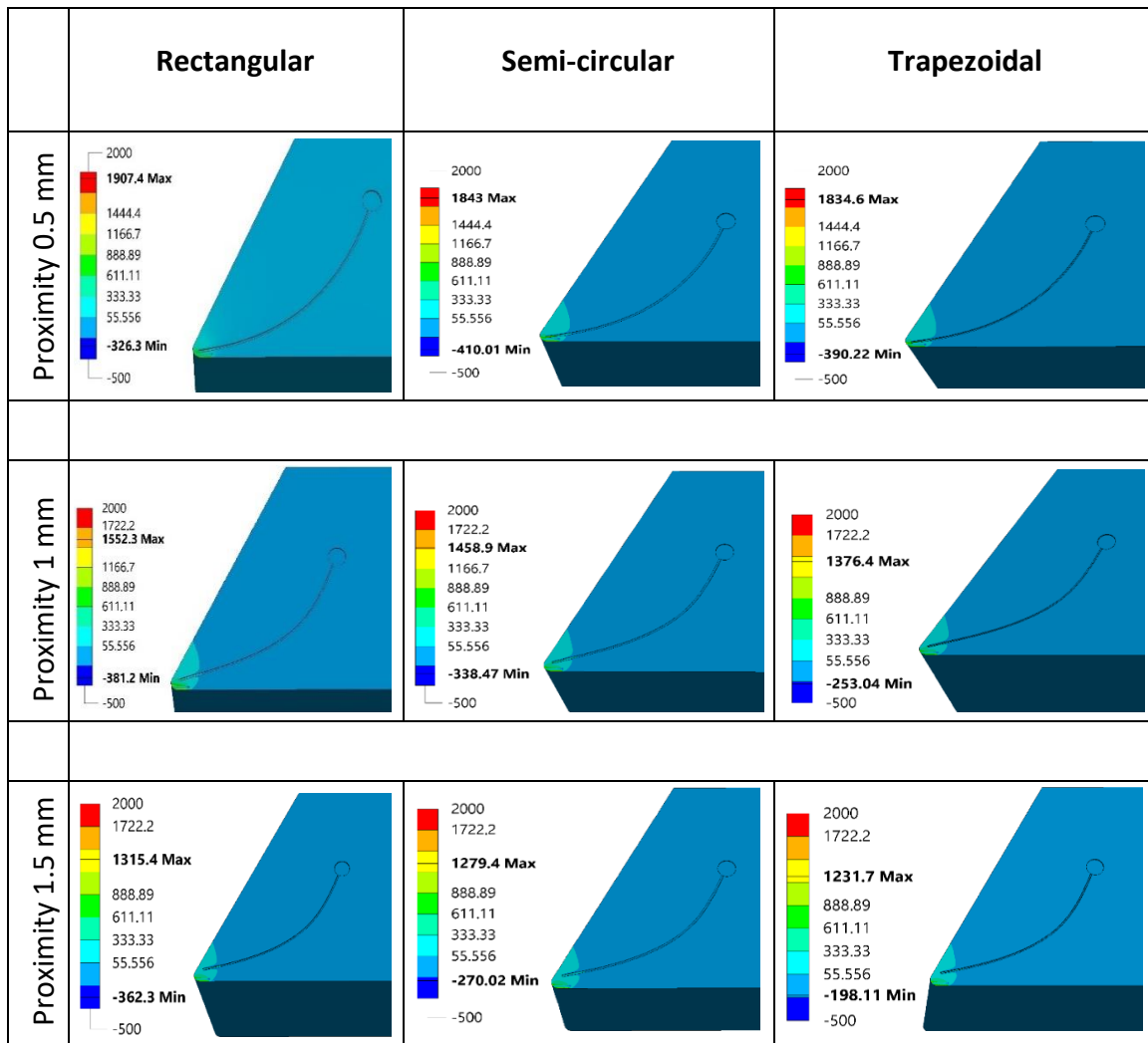

Figure 4.4.1. Maximum Principal Stress (MPa) for cutting tool having microchannel positioned at various proximity from PCE

To analyse it further, Figure 4.4.2, shows the observed trend of maximum principal stress subjected while machining of the considered alloy. Critical analysis of the trend observed in the figure reveals that, maximum principal stress experienced by the considered tool condition grooved with microchannels is approximately 10% to 78% higher when compared to a cutting tool without such microchannels.

This finding suggests that the presence of microchannels on the rake face leads to an enhancement in maximum principal stress within the cutting tool. Despite this elevation in stress levels, it should be emphasized that for all examined variations, maximum principal stress consistently stays beneath the yield strength of the cutting tool material. Consequently, according to the maximum principal stress failure theory (Leckie and Bello, 2009), the cutting

tools are deemed safe for the analysed components subjected to cutting forces. Despite of satisfactory results for all cases, the cutting tool having microchannel with proximity 1.25 mm onwards from principal cutting edge can be opted as per design criteria.

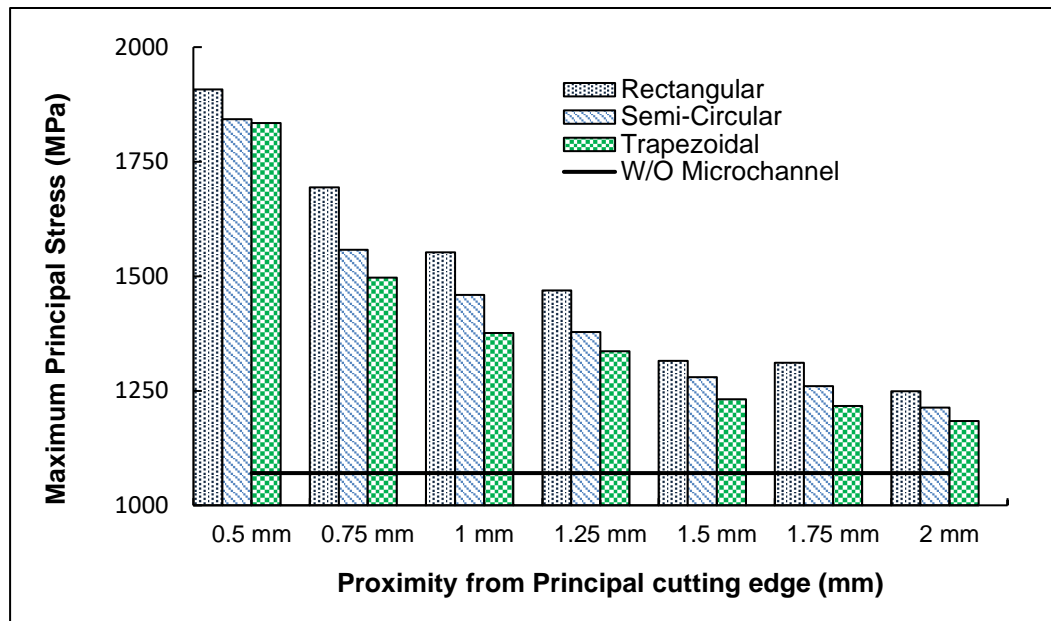

Figure 4.4.2. Fluctuation of maximum principal stress for single microchannel in relation to varying proximity to PCE (reference level for maximum principal stress is 1000 MPa)

The obtained results highlight a direct relationship between the proximity of the generated microchannel and the development of higher stress levels within the cutting tool, with stress levels escalating as the distance from the Principal Cutting Edge (PCE) decreases. Trapezoidal and semi-circular microchannels displays more favourable performance when integrated onto the tool's rake surface due to the relatively lower localized stress generation compared to other geometric shapes. This phenomenon arises because stress lines tend to distribute more uniformly at the corner points of trapezoidal and semi-circular microchannels compared to other configurations. Specifically, the maximum principal stress for trapezoidal microchannels varies from 1834.6 MPa to 1184.3 MPa across different proximities from the principal cutting edge of the tool.

In the case of trapezoidal cross section microchannel, the stress concentration factor under static loading is relatively low due to the gradual change in geometry along the length of the channel. As a result, the stress distribution is relatively uniform and the maximum principal stress is lower than in other types of microchannels. The maximum principal stress for semi-circular microchannels is found to be in close proximity to that of trapezoidal microchannels,

revealing a maximum variation of only 6% greater than that in the case of trapezoidal microchannels. In contrast, rectangular microchannels experiences higher maximum principal stress levels, ranging from approximately 4% to 13% greater than trapezoidal microchannels across varying distances from the principal cutting edge.

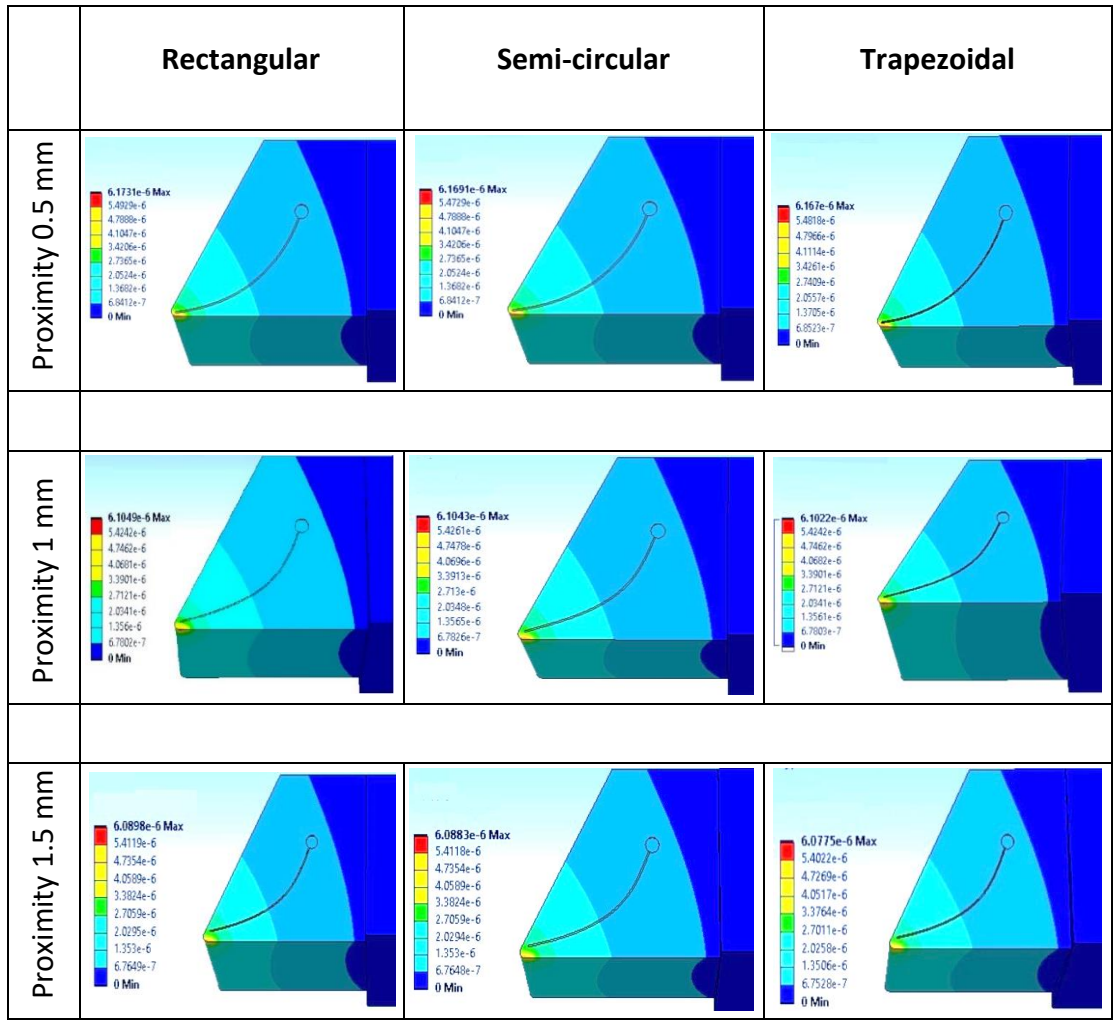
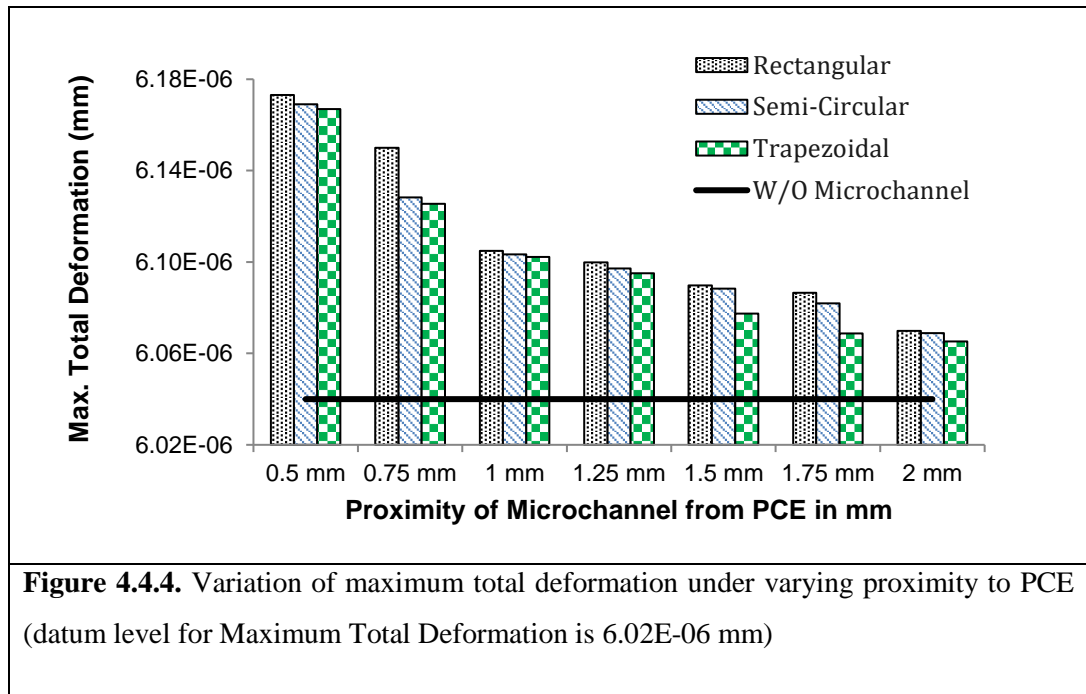

Figure 4.4.3. Result of Maximum Total Deformation (mm) for cutting tool having microchannel positioned at various proximity from PCE

Figure 4.4.3 illustrates a comparative analysis of the maximum total deformation experienced by the cutting tool when subjected to different single microchannel grooved at varying proximity from the principal cutting edge. Across all the considered variations, total deformation was realised to be higher at the region in between engrooved microchannel and PCE. As the tool experiences deformation during cutting, stress concentrations may develop,

leading to the initiation and growth of cracks as it is a direct contributor to crack propagation. The relationship between maximum total deformation and failure may be influenced by the fracture toughness of tungsten carbide that is the measurement of a material's resistance to crack propagation. Higher levels of deformation may lead to increased stress intensity at crack tips, affecting the fracture toughness of the considered tool material. The obtained results are in close agreement of the argument.



Maximum total deformation for cutting tool with microchannel is nearly 0.42% to 2.2% higher in compared to cutting tool without microchannel as shown in Figure 4.4.4. It can be apprehended that due to microchannel generation on the rake face of tool, maximum total deformation developed in the cutting tool is anticipated to be higher. It can be also seen that the results for tools grooved with trapezoidal and semi-circular microchannel are majorly in close proximity and the effects of geometry of microchannel are nearly zero in closest and furthest proximity depicting the uniformity in the considered study.

4.5 Experimental Validation of the Proposed Cutting Tool Model

The obtained results show that the introduction of trapezoidal microchannels on the cutting tool rake face significantly influenced machining performance, impacting cutting forces, machining zone temperature, and surface roughness. This section presents the experimental findings for both Case 1 (microchannel at a proximity of 1 mm from PCE) and Case 2 (microchannel at a

proximity of 1.5 mm from PCE), comparing them with dry machining and small quantity lubrication (SQL) methods.

In Fig. 4.5.1, the study revealed that the cutting force (P_z) is significantly lower for the microchannel-assisted tool compared to dry machining and SQL methods for both cases. This indicates that the microchannel facilitated better lubrication, reducing friction at the tool-workpiece interface (Avila and Abrao, 2001; Sharma *et al.*, 2015; Nilson *et al.*, 2006, Bhandari *et al.* 2024).

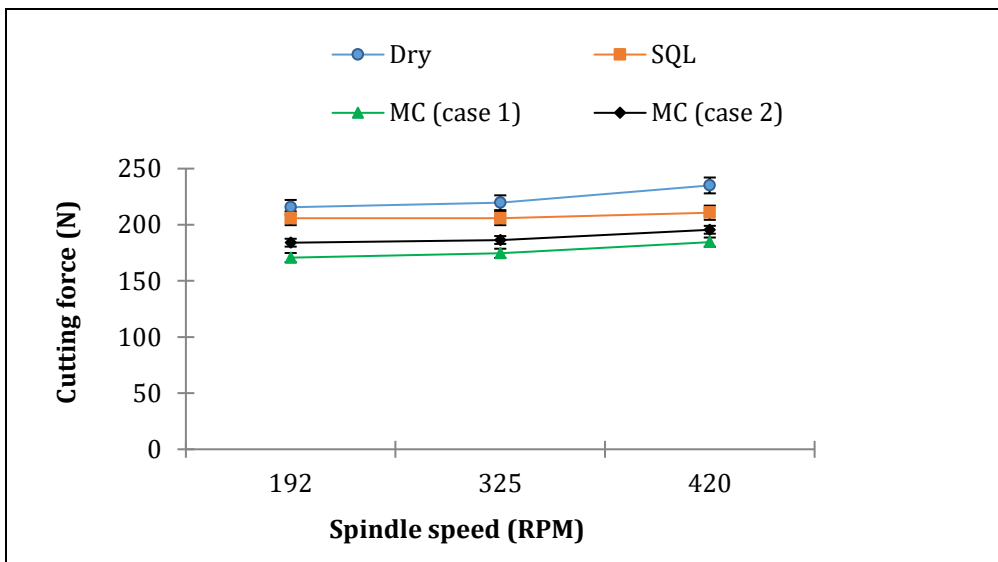
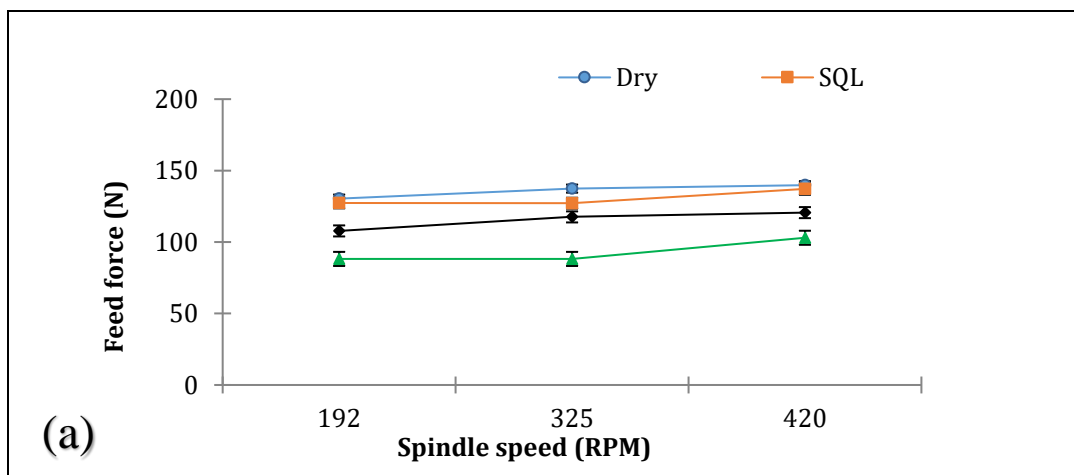

Figure 4.5.1. Comparison of cutting force (P_z)

A similar trend was observed in Fig. 4.5.2. (a) & (b) that for both the cases in feed force (P_f) and thrust force (P_t), where microchannel-assisted machining consistently exhibited lower force values than the other methods, demonstrating its effectiveness.



(a)

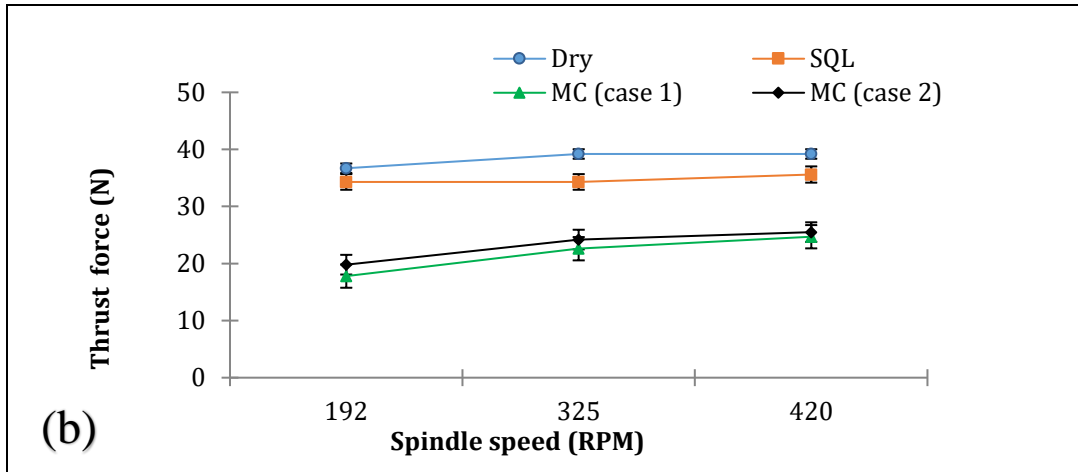

Figure 4.5.2. (a) Comparison of Feed force (P_f) and (b) Comparison of Thrust force (P_t)

Temperature measurements using a Fluke TiS75+ thermal camera shows that microchannel-assisted machining exhibits lower temperatures than dry and SQL machining which is shown in Fig. 4.5.3. This confirms the cooling efficiency of the microchannel, which effectively delivered coolant to the tool-workpiece interface.

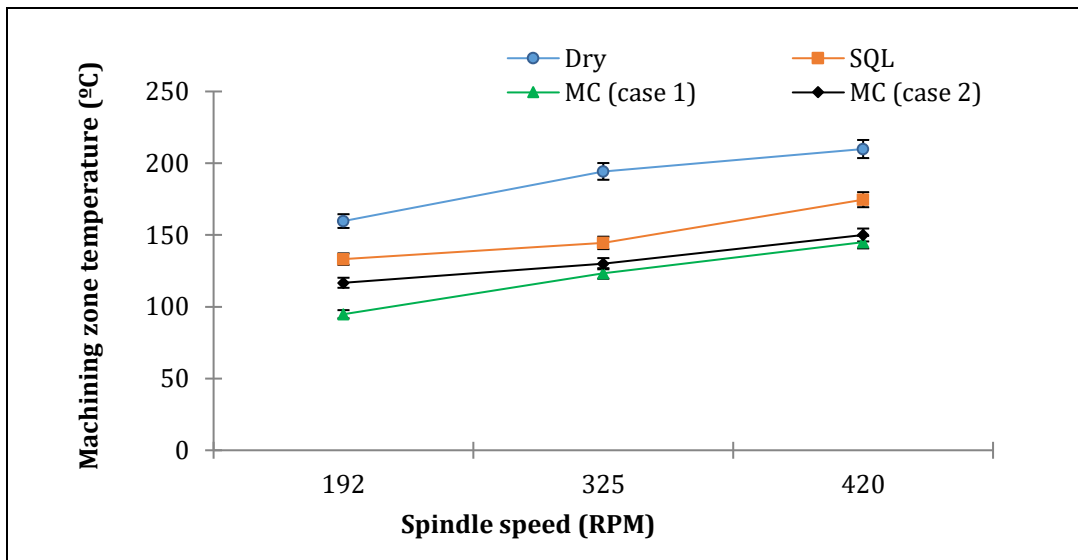

Figure 4.5.3. Variation of temperature with spindle speed in different environments

Surface roughness, measured using a Mitutoyo SJ210 surface roughness tester, demonstrated that microchannel-assisted machining produced a superior surface finish compared to dry and SQL machining for both cases shown in Fig. 4.5.4.

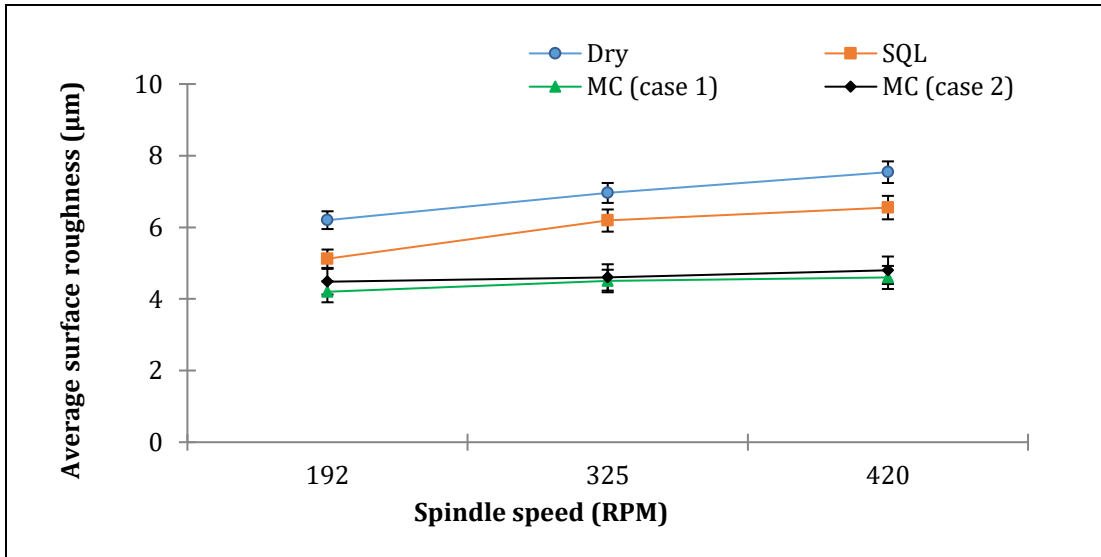

Figure 4.5.4. Variation of average surface roughness with spindle speed in different environments

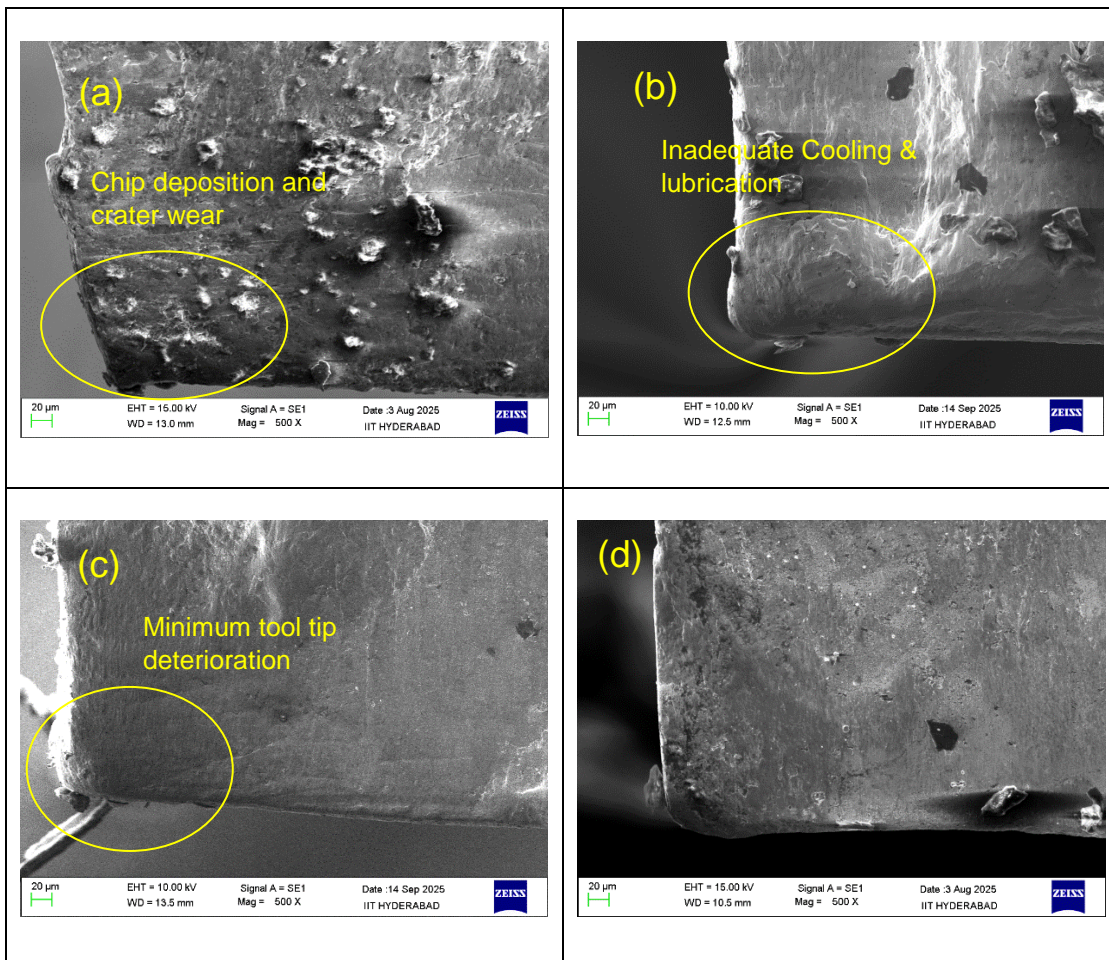

Figure 4.5.5 SEM micrographs of cutting tools under various cutting condition (spindle speed 420 rpm) (a) Dry (b) SQL (c) MC (Case 1) (d) MC (case 2)

The SEM micrographs of cutting tools at a fixed spindle speed 420 rpm under various cooling conditions are shown in Fig. 4.5.5, where it can be seen that under dry condition, chip deformation and crater wear is maximum due to absence of cutting fluid. Also, under SQL condition, flank wear may be seen due to high thrust force and improper lubrication at machining zone. However, it can be observed that in case of cooling through microchannel gives better results than dry and SQL condition. For case 1, where microchannel is positioned at a proximity of 1 mm from PCE, shows better result within these four conditions due to better coolant penetration at machining zone and low cutting forces.

The results of numerical simulation are shown in Fig.4.5.6, where it can be seen that the maximum principal stress for both the cases are much lower than the tensile strength of the M42 HSS material. Also, it can be observed that the maximum principal stress for case 1 is quite higher than the case 2 under the same cutting load condition which indicate the effect of proximity of microchannel from PCE on stress distribution. For case 1, the microchannel is at higher proximity, therefore the local stress concentration becomes higher than the case 2.

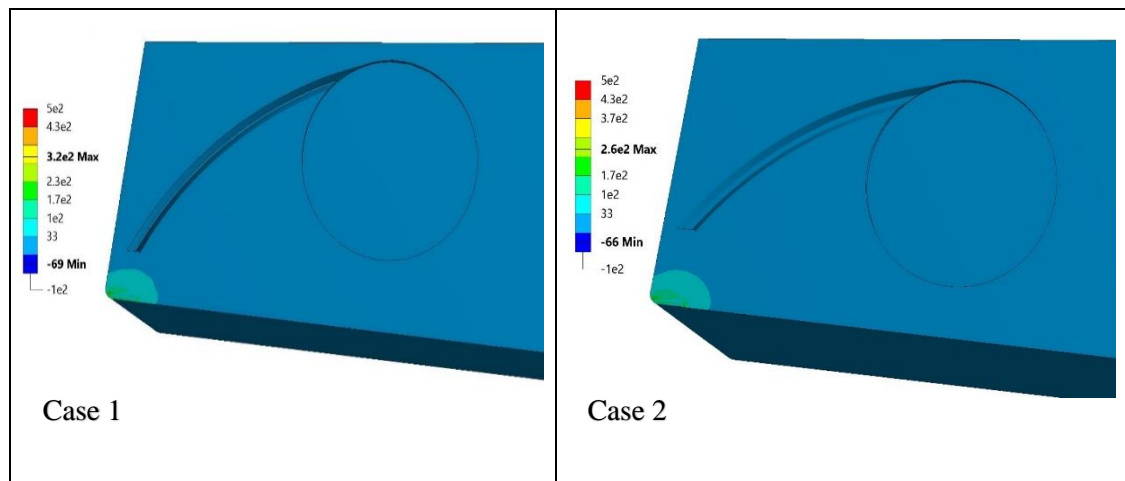

Figure 4.5.6 Maximum Principal Stress (MPa) contour for Case 1 & Case 2

Chapter 5:

Conclusions and Scope of Future Work

5.1 Conclusions

The present research systematically investigates the design, structural viability, and functional performance of microchannel-textured cutting tools for enhanced heat dissipation and machining performance. The study was carried out in four phases, each targeting a specific research objective. The key conclusions from each phase are summarized below:

- **Validation of Numerical Scheme**

- The initial study successfully validates the employed numerical scheme, ensuring its robustness and reliability for analyzing mechanical behavior of cutting tools.
- This validated model forms a solid foundation for the subsequent simulation-based analyses performed throughout the study.

- **Structural Assessment of Microchannel-Textured HSS Tools**

The feasibility of generating microchannels on the rake face of HSS cutting tools was explored with emphasis on structural integrity.

- Introduction of microchannels increases maximum principal stress compared to plain tools.
- Despite the stress increase, values remain well below fracture limits, supporting safe use of microchannel features.
- Trapezoidal microchannels yielded the most favourable stress distribution.
- Incorporating multiple microchannels remains structurally viable, though associated with higher stress levels.

- **Structural Viability in Uncoated Tungsten Carbide Tools**

The study evaluated the influence of microchannel proximity and geometry on stress behavior in uncoated tungsten carbide tools.

- Stress levels increased with the proximity of the microchannel to the principal cutting edge (PCE), suggesting a critical design parameter.
- Trapezoidal and semi-circular microchannels exhibited better performance than rectangular ones, due to smoother stress distribution at corners.

- All simulated stress levels were well below the material yield strength, ensuring safe tool usage.
 - Considering design criteria, tools with microchannel proximity of 1.25 mm or more from PCE showed enhanced structural suitability.
 - Total deformation remained consistent across geometries, indicating minimal impact of microchannel shape on tool deformation.
- **Experimental Evaluation of Microchannel-Textured M42 HSS Tools**

Microchannel-textured M42-grade HSS cutting tools are experimentally evaluated under dry, SQL, and microchannel-assisted cooling during turning of mild steel.

 - Cutting forces (P_z , P_f , P_t) were significantly reduced in microchannel-assisted conditions compared to dry and SQL environments, indicating enhanced lubrication and reduced tool–workpiece friction.
 - Cutting zone temperatures were consistently lower in microchannel-assisted machining, confirming improved thermal regulation via capillary-driven coolant transport.
 - Surface roughness of machined components was notably improved with microchannel tools, reflecting better tool-chip interaction and reduced tool wear.
 - Numerical simulation using ANSYS showed that maximum principal stresses remained well below the tensile strength of M42 HSS in both cases, affirming structural safety.
 - Case 2 exhibited lower stress concentration than Case 1 under identical loading, highlighting the importance of optimal microchannel positioning with respect to the principal cutting edge.
 - Overall, microchannel-assisted tools demonstrated superior thermo-mechanical performance and machining quality, establishing their potential for advanced sustainable manufacturing.

The study establishes the feasibility and advantages of microchannel-textured cutting tools in advanced machining applications. The numerical validation confirmed the reliability of the simulation framework, forming a robust foundation for subsequent structural and experimental analyses. Structural evaluations across HSS and uncoated tungsten carbide tools confirmed that while the integration of microchannels introduces marginal increases in principal stress, the

values remain well within safe operational limits, especially when optimal geometries—such as trapezoidal and semi-circular shapes—and strategic placements are employed. Experimental assessments further reinforced these findings, revealing substantial improvements in cutting force reduction, thermal regulation, and surface finish under microchannel-assisted conditions. Notably, microchannel proximity to the principal cutting edge emerged as a critical parameter influencing both stress distribution and performance outcomes. Collectively, these insights underscore the potential of optimized microchannel-textured tools to enhance tool longevity, efficiency, and sustainability in high-performance machining environments, paving the way for their integration into next-generation manufacturing systems.

The present work involves analyzing the structural and functional feasibility of microchannel-textured cutting tools under static loading conditions. This study does not take care of dynamic structural analysis; which would provide a more comprehensive examination of the subject. The experimental data of Microchannel-Textured M42 HSS Tools under cutting conditions was not validated under dynamic simulation analysis as experimental investigation was mainly focused towards understanding the comparative machinability of microchannel etched cutting tools. This has left for further scope of work that can enrich the understanding of the study further.

5.2 Scope of Future Works

While the present study establishes the structural and functional feasibility of microchannel-textured cutting tools, several avenues remain open for further exploration:

- **Dynamic Structural Analysis**

Future work may involve dynamic structural simulations to evaluate tool behavior under time-dependent and impact loading conditions, thereby providing a more comprehensive understanding of tool performance during actual machining operations.

- **Numerical Analysis of Heat Transfer and Fluid Flow-**

Advanced numerical studies focusing on coupled heat transfer and fluid flow within the microchannels can offer deeper insights into coolant transport mechanisms and thermal regulation efficiency, contributing to optimized microchannel design.

Reference

- Abid, A., Hamza, S.M., Alim, M.K., Muaz, M., Hussain, S. and Arif, S., 2024. Thermal Analysis of Micro-Channel Internal Cooling in Cutting Tools: A Machine Learning Approach. *Applied Mechanics and Materials*, 922, pp.97-107.
- Akyildiz, H.K., 2013. Evaluating of cutting forces in thread machining. *The International Journal of Advanced Manufacturing Technology*, 68(5), pp.1601-1612.
- Alihosseini, Y., Targhi, M. Z., Heyhat, M. M., & Ghorbani, N. (2020). Effect of micro heat sink geometric design on thermo-hydraulic performance: A comprehensive review. *Applied Thermal Engineering*, 175, 115305.
- Arunachalam, R.M., Mannan, M.A. and Spowage, A.C., 2004. Residual stress and surface roughness when facing age hardened Inconel 718 with CBN and ceramic cutting tools. *International Journal of Machine Tools and Manufacture*, 44(9), pp.879-887.
- Aslantas, K., Ucun, I. and Cicek, A., 2012. Tool life and wear mechanism of coated and uncoated Al₂O₃/TiCN mixed ceramic tools in turning hardened alloy steel. *Wear*, 274, pp.442-451.
- Aurich, J.C., Dornfeld, D., Arrazola, P.J., Franke, V., Leitz, L. and Min, S., 2009. Burrs—Analysis, control and removal. *CIRP annals*, 58(2), pp.519-542.
- Avila, R. F., & Abrao, A. M. (2001). The effect of cutting fluids on the machining of hardened AISI 4340 steel. *Journal of Materials Processing Technology*, 119(1-3), 21-26.
- Bhandari P, Rawat K S, Prajapati Y K, Padalia D, Ranakoti L and Singh T, 2023. A review on design alteration in microchannel heat sink for augmented thermohydraulic performance. *ASEJ*. 15(2): 102417.
- Bhandari, P., Rawat, K. S., Prajapati, Y. K., Padalia, D., Ranakoti, L., & Singh, T. (2024). A review on design alteration in microchannel heat sink for augmented thermohydraulic performance. *Ain Shams Engineering Journal*, 15(2), 102417.
- Bhemuni, V., Chalamalasetti, S.R., Konchada, P.K. and Pragada, V.V., 2015. Analysis of hard turning process: thermal aspects. *Advances in Manufacturing*, 3(4), pp.323-330.
- Binali, R., Patange, A.D., Kuntoğlu, M., Mikolajczyk, T. and Salur, E., 2022. Energy saving by parametric optimization and advanced lubri-cooling techniques in the machining of composites and superalloys: A systematic review. *Energies*, 15(21), p.8313.

- Biswojyothi, M., Balan, A.S.S., Arunachalam, N. and Vijayaraghavan, L.A., 2014. A study on the minimum quantity lubrication in grinding of titanium alloy (Ti-6Al-4V). *In 5th International & 26th All India Manufacturing Technology, Design and Research Conference* (pp. 12-14).
- Brandão, G.L., Silva, P.M.D.C., de Freitas, S.A., Pereira, R.B.D., Lauro, C.H. and Brandão, L.C., 2020. State of the art on internal thread manufacturing: a review. *The International Journal of Advanced Manufacturing Technology*, 110(11), pp.3445-3465.
- Cakir M C and Yahya I S, 2005. Finite element analysis of cutting tools prior to fracture in hard turning operations. *Mater. Des.* 26(2): 105-112.
- Chaudhari, S.S., Khedkar, S.S. and Borkar, N.B., 2011. Optimization of process parameters using Taguchi approach with minimum quantity lubrication for turning. *International Journal of Engineering Research and Applications (IJERA)*, 1(4), pp.1268-1273.
- Childs, T.H.C., Maekawa, K. and Maulik, P., 1988. Effects of coolant on temperature distribution in metal machining. *Materials science and technology*, 4(11), pp.1006-1019.
- Dahmus, J. B., & Gutowski, T. G. (2004). An environmental analysis of machining. *Proceedings of the ASME International Mechanical Engineering Congress and Exposition*, 123, 643-651.
- Das, A., Gupta, M.K., Das, S.R., Panda, A., Patel, S.K. and Padhan, S., 2022. Hard turning of AISI D6 steel with recently developed HSN2-TiAlxN and conventional TiCN coated carbide tools: comparative machinability investigation and sustainability assessment. *Journal of the Brazilian Society of Mechanical Sciences and Engineering*, 44(4), p.138.
- Debnath, S., Reddy, M.M. and Yi, Q.S., 2016. Influence of cutting fluid conditions and cutting parameters on surface roughness and tool wear in turning process using Taguchi method. *Measurement*, 78, pp.111-119.
- Deng D, Pi G, Zhang W, Wang P and Fu T, 2018. Numerical study of double-layered microchannel heat sinks with different cross-sectional shapes. *Entropy*. 21(1): 16.
- Dhar, N. R., Paul, S., & Chattopadhyay, A. B. (2002). The role of cryogenic cooling on cutting temperature in turning steel. *Journal of Materials Processing Technology*, 116(1), 44-48.
- Ezugwu, E.O. and Wang, Z.M., 1997. Titanium alloys and their machinability—a review. *Journal of materials processing technology*, 68(3), pp.262-274.

- Gilmore, N., Timchenko, V., & Menictas, C. (2020). Open manifold microchannel heat sink for high heat flux electronic cooling with a reduced pressure drop. *International Journal of Heat and Mass Transfer*, 163, 120395.
- Glinka, G., 1985. Calculation of inelastic notch-tip strain-stress histories under cyclic loading. *Engineering Fracture Mechanics*, 22(5), pp.839-854.
- Goindi, G.S. and Sarkar, P., 2017. Dry machining: a step towards sustainable machining—challenges and future directions. *Journal of cleaner production*, 165, pp.1557-1571.
- Groover, M.P., 2020. Fundamentals of Modern Manufacturing: Materials, Processes, and Systems. John Wiley & Sons.
- Gross, B. and Mendelson, A., 1972. Plane elastostatic analysis of V-notched plates. *International Journal of Fracture Mechanics*, 8(3), pp.267-276.
- Guo, G., Liu, Z., An, Q. and Chen, M., 2012. Investigation on surface grinding of Ti-6Al-4V using minimum quantity lubrication. *International Journal of Abrasive Technology*, 5(3), pp.187-201.
- Haron, C.C., Ginting, A. and Goh, J.H., 2001. Wear of coated and uncoated carbides in turning tool steel. *Journal of materials processing technology*, 116(1), pp.49-54.
- He, T., Liu, N., Xia, H., Wu, L., Zhang, Y., Li, D. and Chen, Y., 2023. Progress and trend of minimum quantity lubrication (MQL): A comprehensive review. *Journal of Cleaner Production*, 386, p.135809.
- Hegab, H., Kishawy, H.A., Gadallah, M.H., Umer, U. and Deiab, I., 2018. On machining of Ti-6Al-4V using multi-walled carbon nanotubes-based nano-fluid under minimum quantity lubrication. *The International Journal of Advanced Manufacturing Technology*, 97, pp.1593-1603.
- Hong, F., & Cheng, P. (2009). Three dimensional numerical analyses and optimization of offset strip-fin microchannel heat sinks. *International Communications in Heat and Mass Transfer*, 36(7), 651–656.
- Hong, S.Y. and Ding, Y., 2001. Cooling approaches and cutting temperatures in cryogenic machining of Ti-6Al-4V. *International Journal of Machine Tools and Manufacture*, 41(10), pp.1417-1437.
- Jin, S.Y., Pramanik, A., Basak, A.K., Prakash, C., Shankar, S. and Debnath, S., 2020. Burr formation and its treatments—a review. *The International Journal of Advanced Manufacturing Technology*, 107, pp.2189-2210.

- Kabov, O. A., et al. "Evaporation and flow dynamics of thin, shear-driven liquid films in microgap channels." *Experimental Thermal and Fluid Science* 35, no. 5 (2011): 825-831.
- Klocke, F., & Eisenblätter, G. (1997). Dry cutting. *CIRP Annals*, 46(2), 519-526.
- Knight, W.A. and Boothroyd, G., 2019. Fundamentals of metal machining and machine tools. CRC Press.
- Ko, S.L. and Lee, J.K., 2001. Analysis of burr formation in drilling with a new-concept drill. *Journal of materials processing technology*, 113(1-3), pp.392-398.
- Krawczyk, B., Szablewski, P., Mendak, M., Gapiński, B., Smak, K., Legutko, S., Wieczorowski, M. and Miko, E., 2022. Surface topography description of threads made with turning on Inconel 718 shafts. *Materials*, 16(1), p.80.
- Kumar, A., Bhardwaj, R. and Joshi, S.S., 2022. Thermal analysis of drilling in titanium under flood and cryogenic cooling using coupled CFD and FEM. *Journal of Manufacturing Processes*, 81, pp.605-623.
- Kundu, A., Mukhopadhyay, M., Mahata, S., Banerjee, A., Mandal, B. and Das, S., 2018. Grinding Titanium grade 1 alloy with an alumina wheel using soap water. *Procedia Manufacturing*, 20, pp.338-343.
- Leckie F A and Bello D J, 2009. Strength and stiffness of engineering systems. *Springer Science & Business Media*. 277-292.
- Liao, Z., Xu, D., Axinte, D., M'Saoubi, R., Thelin, J. and Wretland, A., 2020. Novel cutting inserts with multi-channel irrigation at the chip-tool interface: modelling, design and experiments. *Cirp Annals*, 69(1), pp.65-68.
- Lu, T., Kudaravalli, R. and Georgiou, G., 2018. Cryogenic machining through the spindle and tool for improved machining process performance and sustainability: Pt. I, system design. *Procedia Manufacturing*, 21, pp.266-272.
- Mahata, S., Kundu, A., Mukhopadhyay, M., Banerjee, A., Mandal, B. and Das, S., 2018. Exploring grind ability of Inconel 718 using small quantity cooling and lubrication technique. *Materials Today: Proceedings*, 5(2), pp.4523-4530.
- Mahata, S., Mandal, B., Mistri, J. and Das, S., 2014. Effect of fluid concentration using a multi-nozzle on grinding performance. *International Journal of Abrasive Technology*, 6(4), pp.257-268.
- Malkin, S. and Guo, C., 2007. Thermal analysis of grinding. *CIRP annals*, 56(2), pp.760-782.

Malkin, S. and Guo, C., 2008. Grinding technology: theory and application of machining with abrasives. Industrial Press Inc.

Mitra, I., & Ghosh, I. (2021). Analytical closed-form solution for fluid flow through microchannel heat sinks including axial conduction. *International Communications in Heat and Mass Transfer*, 129, 105732.

Mukhopadhyay, M. and Kundu, P.K., 2020. Improving grindability of Ti-6Al-4V using an economic and environmental friendly drop by drop delivery technique. *Materials Today: Proceedings*, 27, pp.2081-2085.

Narvydas, E. and Puodžiūnienė, N., 2012. Circumferential stress concentration factors at the asymmetric shallow notches of the lifting hooks of trapezoidal cross-section. *Mechanika.*, 18(2), pp.152-157.

Neuber, H., 1961. Theory of stress concentration for shear-strained prismatical bodies with arbitrary nonlinear stress-strain law.

Nilson, R. H., et al. "Steady evaporating flow in rectangular microchannels." *International Journal of Heat and Mass Transfer* 49, no. 9-10 (2006): 1603-1618.

Noda, N.A. and Takase, Y., 2003. Generalized stress intensity factors of V-shaped notch in a round bar under torsion, tension, and bending. *Engineering Fracture Mechanics*, 70(11), pp.1447-1466.

Noda, N.A., Sera, M. and Takase, Y., 1995. Stress concentration factors for round and flat test specimens with notches. *International Journal of Fatigue*, 17(3), pp.163-178.

Osman, K.A., Ünver, H.Ö. and Şeker, U., 2019. Application of minimum quantity lubrication techniques in machining process of titanium alloy for sustainability: a review. *The International Journal of Advanced Manufacturing Technology*, 100, pp.2311-2332.

Özel T, Sima M, Srivastava A K. and Kaftanoglu B, 2010. Investigations on the effects of multi-layered coated inserts in machining Ti-6Al-4V alloy with experiments and finite element simulations. *CIRP Ann. - Manuf. Technol.* 59(1): 77-82.

Ozguç, O., Arslan, E., & Uysal, B. Z. (2021). Topology optimization of microchannel heat sinks using a homogenization approach. *Engineering Optimization*, 53(7), 1163–1182.

Peng, R., Jiang, H., Tang, X., Huang, X., Xu, Y. and Hu, Y., 2019. Design and performance of an internal-cooling turning tool with micro-channel structures. *Journal of Manufacturing Processes*, 45, pp.690-701.

Pimenov, D.Y., da Silva, L.R.R., Machado, A.R., França, P.H.P., Pintaude, G., Unune, D.R., Kuntoğlu, M. and Krolczyk, G.M., 2024. A comprehensive review of machinability of difficult-to-machine alloys with advanced lubricating and cooling techniques. *Tribology International*, p.109677.

Pimenov, D.Y., Mia, M., Gupta, M.K., Machado, A.R., Tomaz, Í.V., Sarikaya, M., Wojciechowski, S., Mikolajczyk, T. and Kapłonek, W., 2021. Improvement of machinability of Ti and its alloys using cooling-lubrication techniques: A review and future prospect. *Journal of materials research and technology*, 11, pp.719-753.

Rehman, M. M. U., Cheema, T. A., Ahmad, F., Khan, M., & Abbas, A. (2020). Thermodynamic assessment of microchannel heat sinks with novel sidewall ribs. *Journal of Thermophysics and Heat Transfer*, 34(2), 243–254.

Roy, S., Kumar, R., Sahoo, A.K. and Das, R.K., 2019. A brief review on effects of conventional and nano particle based machining fluid on machining performance of minimum quantity lubrication machining. *Materials Today: Proceedings*, 18, pp.5421-5431.

Sadeghi, M.H., Haddad, M.J., Tawakoli, T. and Emami, M., 2009. Minimal quantity lubrication-MQL in grinding of Ti-6Al-4V titanium alloy. *The International Journal of Advanced Manufacturing Technology*, 44, pp.487-500.

Sadik, M.I. and Isakson, S., 2017. The role of PVD coating and coolant nature in wear development and tool performance in cryogenic and wet milling of Ti-6Al-4V. *Wear*, 386, pp.204-210.

Sadique, H., & Murtaza, Q. (2022). Heat transfer augmentation in microchannel heat sink using secondary flows: A review. *International Journal of Heat and Mass Transfer*, 194, 123063.

Safie, N.S.S., Murad, M.N., Lih, T.C., Azmi, A.I., Wan Hamzah, W.A. and Danish, M., 2022. Roles of Eco-Friendly Non-Edible vegetable oils in drilling inconel 718 through minimum quantity lubrication. *Lubricants*, 10(9), p.211.

Santra, A., Mukhopadhyay, M. and Chanda, A., 2023. Estimating Tool Strength of Single Point Cutting Tool with Engrooved Micro-Channel on Rake Face: An Experimental Assisted Simulative Analysis. *Journal of The Institution of Engineers (India): Series C*, 104(5), pp.1011-1021.

Santra, A., Mukhopadhyay, M. and Chanda, A., 2024. Microchannel engrooved carbide tool rake: a feasibility study for machining Ti-6Al-4V. *Sādhanā*, 49(4), p.283.

- Sastry, C.C., Gokulakrishnan, K., Hariharan, P., Kumar, M.P. and Boopathy, S.R., 2020. Investigation of boring on gunmetal in dry, wet and cryogenic conditions. *Journal of the Brazilian Society of Mechanical Sciences and Engineering*, 42(1), p.16.
- Seah, K. H. W., et al. (1995). Tool wear and surface roughness in turning under different cooling conditions. *Journal of Materials Processing Technology*, 48(1-4), 361-374.
- Senevirathne, S.W.M.A.I. and Fernando, M.A.R.V., 2012, February. Effect of cryogenic cooling on machining performance on hard to cut metals-a literature review. In Proc. *National Engineering Conference* (Vol. 27, pp. 38-46).
- Setti, D., Sinha, M.K., Ghosh, S. and Rao, P.V., 2015. Performance evaluation of Ti–6Al–4V grinding using chip formation and coefficient of friction under the influence of nanofluids. *International Journal of Machine Tools and Manufacture*, 88, pp.237-248.
- Sharma, V.S., Dogra, M. and Suri, N.M., 2009. Cooling techniques for improved productivity in turning. *International Journal of Machine Tools and Manufacture*, 49(6), pp.435-453.
- Sharma, V.S., Singh, G. and Sørby, K., 2015. A review on minimum quantity lubrication for machining processes. *Materials and manufacturing processes*, 30(8), pp.935-953.
- Sidik, N.A.C., Samion, S., Ghaderian, J. and Yazid, M.N.A.W.M., 2017. Recent progress on the application of nanofluids in minimum quantity lubrication machining: A review. *International Journal of Heat and Mass Transfer*, 108, pp.79-89.
- Silva, F.J., 2021. Metal Machining—Recent Advances, Applications, and Challenges. *Metals*, 11(4), p.580.
- Singh, R. and Sharma, V., 2022. CFD based study of fluid flow and heat transfer effect for novel turning tool configured with internal cooling channel. *Journal of Manufacturing Processes*, 73, pp.164-176.
- Sousa, V.F. and Silva, F.J., 2020. Recent advances on coated milling tool technology—a comprehensive review. *Coatings*, 10(3), p.235.
- Sridhar, B.R., Devananda, G., Ramachandra, K. and Bhat, R., 2003. Effect of machining parameters and heat treatment on the residual stress distribution in titanium alloy IMI-834. *Journal of Materials Processing Technology*, 139(1-3), pp.628-634.
- Walter, D.P., Pilkey, D.F.P.Z.B. and Zhuming, B., 2008. Peterson's stress concentration factors. *Peterson's Stress Concentration Factors*, pp.589-601.

Wang, R. J., et al. "Parameterization investigation on the microchannel heat sink with slant rectangular ribs by numerical simulation." *Applied Thermal Engineering* 133 (2018): 428-438.

Wei, W., Robles-Linares, J.A., Liao, Z., Wang, Z., Luna, G.G., Billingham, J. and Axinte, D., 2022. On modelling coolant penetration into the microchannels at the tool-workpiece interface. *Journal of Manufacturing Processes*, 84, pp.43-54.

Xavior, M.A. and Adithan, M., 2009. Determining the influence of cutting fluids on tool wear and surface roughness during turning of AISI 304 austenitic stainless steel. *Journal of materials processing technology*, 209(2), pp.900-909.

Xiao, W., Zi, Y., Chen, B., Li, B. and He, Z., 2014. A novel approach to machining condition monitoring of deep hole boring. *International Journal of Machine Tools and Manufacture*, 77, pp.27-33.

Yallese, M.A., Chaoui, K., Zeghib, N., Boulanouar, L. and Rigal, J.F., 2009. Hard machining of hardened bearing steel using cubic boron nitride tool. *Journal of materials processing technology*, 209(2), pp.1092-1104.

Zawada-Tomkiewicz, A., Żurawski, L., Tomkiewicz, D. and Szafraniec, F., 2021. Sustainability and tool wear of titanium alloy thread cutting in dry and cryogenic conditions. *The International Journal of Advanced Manufacturing Technology*, 114(9), pp.2767-2781.

Zou, Y., Tang, K., Guo, G. and Tang, Y., 2024. Forming mechanism of leaf-like integral outside finned tubes via sequential knurling and cutting-bending method. *The International Journal of Advanced Manufacturing Technology*, 131(7), pp.3729-3737.

Abin dan Sante
25/11/2025

Deenab
25/11/2025
Professor
Dept. of Mechanical Engineering
Jadavpur University, Kolkata-32

Yanishu
25-11-25

Head of the Department
Mechanical Engineering Department
Meghnad Saha Institute of Technology