

Ref. Ex/PG/AuE/T/112A/2024

Master of Engineering (Automobile Engg.) Examination, 2024
(1st Semester)
Automotive Chassis and Transmission

Time: Three hours

Full Marks: 100

Missing data if any are to be reasonably assumed.
 Symbols have their usual meanings

Answer any five questions:

1. A truck has a gross vehicle weight of 89000 N, engine displacement is 10 m³, power 77.3 kW at governed speed of 2400 rpm, maximum torque 350 Nm at 1400 rpm. Rear axle ratio 6.166: 1, fourth speed reduction ratio in transmission 1.605:1, drive line losses amount to 10.7 kW at 2400 rpm and 6.3 kW at 1400 rpm tyre size 0.4572 x 1.016 m (effective wheel diameter 0.950 m), frontal area of truck 6.95 m . Calculate the grades which the vehicle can climb in fourth gear in still air condition using the following equation for total resistance

$$R = KW + K_a AV^2 + W \sin \theta \text{ where } K_a = 0.0462 \text{ and } V \text{ in Km/hr} \quad 20$$

2. (a) An automotive type disc clutch is shown in Fig. 1. Name the parts shown by arrows in the figure and explain the working principle of the clutch.

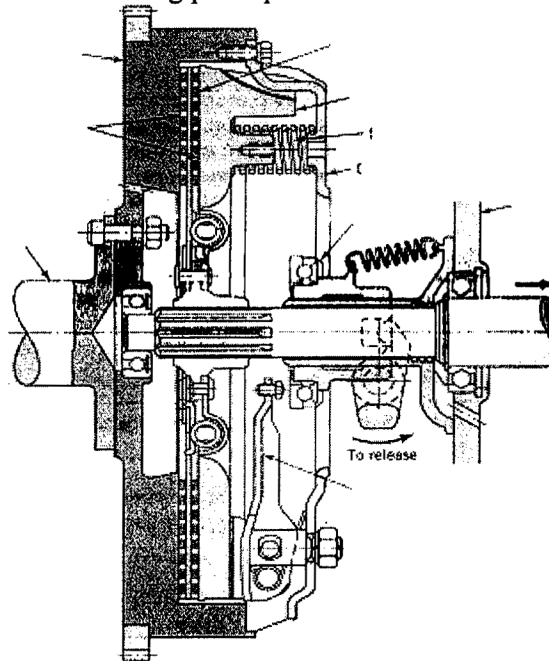

Fig. 1

(b) (a) A single plate clutch, effective on both sides, is required to transmit 25 kW at 3000 rpm. The co-efficient of friction of the lining materials is 0.255. The ratio of the diameters is to be 1.25 and the maximum pressure is not to exceed 0.1 N/mm². Assuming the theory of uniform wear calculate

[Turn over

(i) the inner and outer diameters of the clutch and (ii) the axial thrust to be provided by the springs

10 + 10

3. (a) Fig. 2 shows the configuration of automatic transmission power glide in low gear. Explain the working principle with the help of the figure.

(b) Also explain the importance of planetary gear system in connection to automatic transmission.

12 + 8

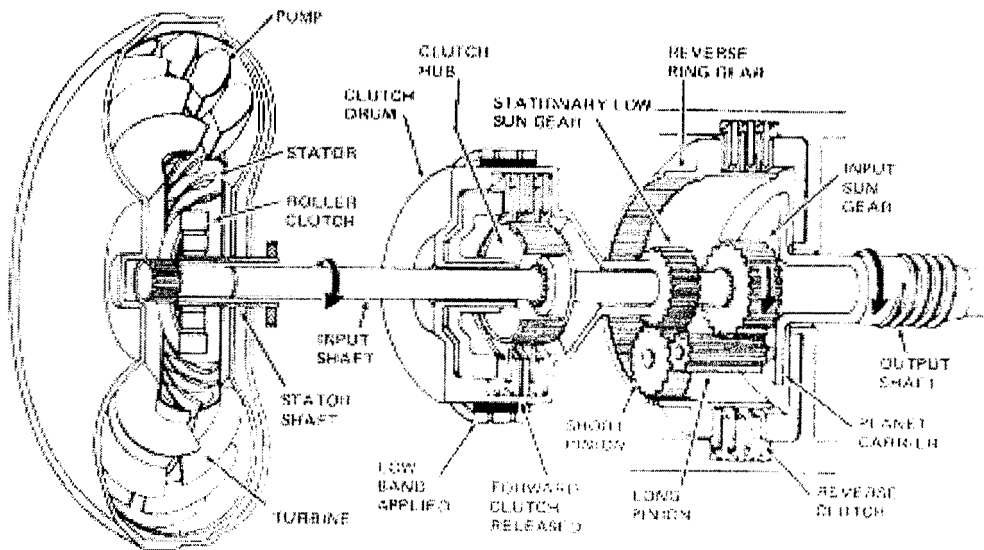

Fig. 2

4. (a) Why do we require a gear box in an automobile?

(b) Explain with the help of a neat sketch, the need of a differential in a typical automotive system?

10 + 10

5. (a) Explain the working principle of a torque converter with the help of sketches.

(b) Why is free wheeling mechanism necessary for proper functioning of torque converter?

12 + 8

6. (a) What are the functional differences between a live axle and a dead axle?

(b) What do you understand by independent suspension system? Give two examples and explain their advantages and disadvantages?

(c) Explain Hotchkiss drive with a neat sketch.

(d) MacPherson strut suspension system is very popular among various car manufacturers – justify the statement.

4 + 6 + 5 + 5

7. (a) Explain with the help of a neat sketch, the need of a differential in a typical automotive transmission.

(b) Fig. 3 shows a synchronizing devices generally used in a gear box. Explain the utility and operation of the device in context to the figure shown. Also indicate the components

marked by the letters N, C, T, H, R, G, M, V and B.

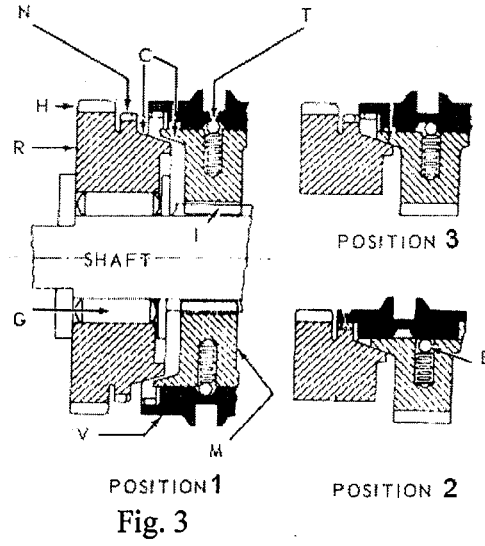

10 +10