

**B. E. (ELECTRICAL ENGINEERING) 5TH YR 1ST SEMESTER
EXAMINATION, 2024**

SUBJECT: - PROCESS INSTRUMENTATION AND CONTROL

Time: Three hours

Full Marks: 100 (50 marks for each part)

Use a separate Answer-Script for each part

PART I

Answer any **THREE** questions. Two marks are reserved for well organised answer.

1. a) Draw the instrumentation diagram for the following process: 4+12
 Flow rate in a liquid pipe line is controlled with a local electronic flow controller. The flow signal is obtained from a differential pressure transmitter and a square root extractor. The differential pressure is obtained from an orifice plate in the pipe line.
 b) Prove that in a digital PD controller's output with anti-derivative kick,
$$m_n = k_p e_n - \frac{K_p T_d}{\tau} c_n + \frac{K_p T_d}{\tau} c_{n-1} + b_n$$
, where m_n is the controller output sequence, b_n is the bias, c_n is the process output and e_n is the error sequence.
2. a) What is integral wind up in process controllers? Describe two schemes of your choice which can be implementations of efficient techniques for anti-integral wind up action. 8+8
 b) Why are relay valves employed in pneumatic proportional controllers? Describe a scheme for implementation of pneumatic P-controllers with direct acting relay.
3. With a neat schematic diagram obtain the transfer function of a simple electronic analog PID controller using two OP-AMP. 16
4. a) Discuss about the spring and diaphragm pneumatic actuator in reverse and direct acting modes. 9+7
 b) What are the basic designs available in rotary valves? List their advantages over conventional globe valves.
5. Write Short notes on any two: 8×2
 - a) Equal Percentage Control Valves;
 - b) Spring diaphragm type actuator with positioner;
 - c) Pneumatic Piston Actuator;
 - d) SATT-CONTROL Auto-tuner.

[Turn over

B. E. (ELECTRICAL ENGINEERING) 5TH YEAR 1ST SEMESTER EXAMINATION, 2024

Subject: PROCESS INSTRUMENTATION & CONTROL Time: Three Hours Full Marks: 100

Part II (50 marks)

Question No.	Question 1 is compulsory <u>Answer Any Two questions from the rest (2×20)</u>	Marks
Q1	Answer <i>any Two</i> of the following:	
(a)	Define, with the help of a schematic diagram, the following terms associated with a closed-loop process control system: (i) Controlled Variable, (ii) Actuating Signal, (iii) Manipulated Variable.	5
(b)	What is feed-forward control? How is it different from feedback control?	5
(c)	Describe “Lumped-parameter” and “Distributed Parameter” models with suitable examples.	5
(d)	Why PID controller is called a “Gain-Reset-Preact Controller”?	5
Q2	(a) What are “Integral Balance” and “Instantaneous Balance” techniques of process modeling? Obtain the model of a “Liquid Surge Tank” using both the methods.	2+4
	(b) What is <i>Process Time Lag</i> ? What are the main factors responsible for it?	2+4
	(c) Figure Q2(c) shows a schematic diagram of the Lube Oil Cooler and associated temperature control scheme. Obtain the block diagram for the closed-loop control scheme and show the various signals and variables associated with it.	

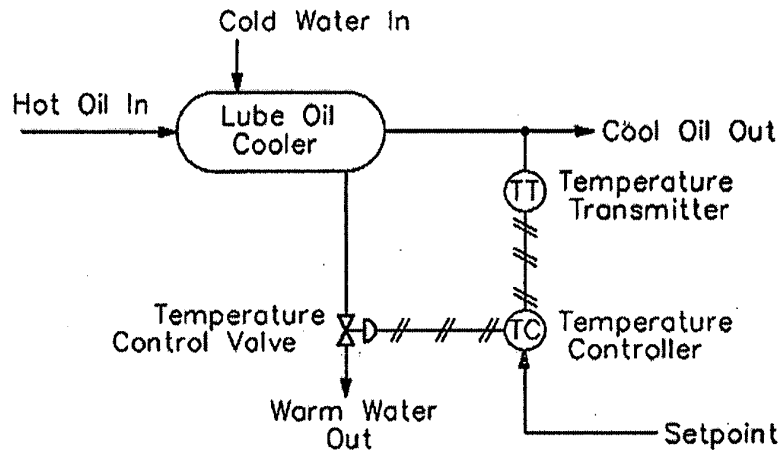

Figure Q2(c)

Q3	(a) What is <i>Inferential Control</i> ? With the help of a block diagram discuss the function of a Soft Sensor in an Inferential Control Scheme.	2+4
	(b) Explain, with an example, why in practical applications feed-forward control is generally used in combination with feedback control.	6
	(c) What is Ratio Control? With the help of schematic diagrams discuss the different Ratio Control methods.	2+6

- Q4 (a) Justify the following statement: 4
 For a type-0 system, PI-controller can eliminate the steady-state offset for step change in input while P-controller can only reduce it.
- (b) Develop the block diagram of the PID control scheme in parallel form. 4
- (c) What is *Set Point Kick*? What are the main components of it? 2+2
 Show, with the help of block diagrams, how the PID controller configurations need to be modified to eliminate such phenomena. 8
- Q5 (a) What is Cascade Control? When does such control scheme become useful? 2+2
- (b) Consider the natural draft furnace temperature control problem. Figure Q5(b) shows a cascade control configuration for the furnace, which consists of a primary control loop (utilizing TT and TC) and a secondary control loop that controls the fuel gas pressure via PT and PC.
- Develop the block diagram for this cascade control system specifying the variables and controllers associated with the primary and secondary control loops.

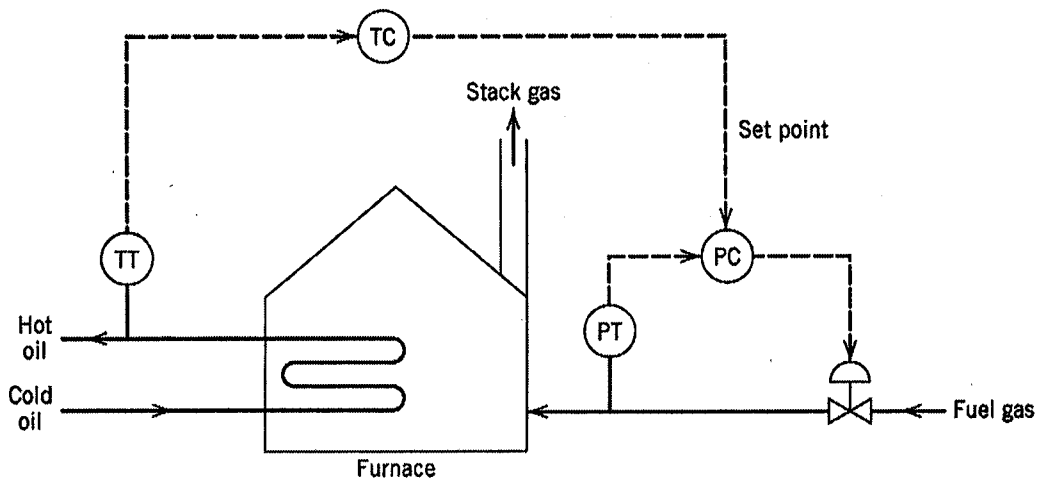

Figure Q5(b)

- (c) What are *Selectors*? 2
 With proper example discuss the operations of *High* and *Median Selectors*. 4